

## SPECIFICATIONS

### Torque Specifications

Description	Nm	lb-ft	lb-in
Antenna mast	3	—	27
Audio control module (ACM) screws	3	—	27
Door speaker mounting bracket screws	1	—	9
Door speaker screws	1	—	9
Door subwoofer amplifier nuts	3	—	27
L-bracket screws	3	—	27
Luggage compartment subwoofer amplifier nuts	5	—	44
Luggage compartment subwoofer amplifier rack bolts	15	11	—

### Torque Specifications (Continued)

Description	Nm	lb-ft	lb-in
Luggage compartment subwoofer amplifier rack nut	15	11	—
Parcel shelf speaker screws	1	—	9
Quarter panel speaker mounting bracket screws	1	—	9
Quarter panel speaker screws	1	—	9
Satellite radio antenna bolt	5	—	44
Satellite digital audio receiver system (SDARS) module nuts	7	—	62
Speaker enclosure bolts	11	8	—
Speaker enclosure nut	11	8	—

---

## DESCRIPTION AND OPERATION

### Information and Entertainment System

#### Audio Line-Up

The following audio systems are available:

- Base
  - AM/FM Single CD
  - 4 full-range speakers
- 500 watt
  - AM/FM 6-CD with MP3 capabilities
  - 2 full-range speakers
  - 2 Audiophile 2-way speakers
  - 2 door-mounted, 8-inch subwoofer speakers
- 1,000 watt
  - AM/FM 6-CD with MP3 capabilities
  - 2 full-range speakers
  - 2 Audiophile 2-way speakers
  - 2 door-mounted, 8-inch subwoofer speakers
  - 2-speaker subwoofer enclosure (in luggage compartment)
  - 4 rack-mounted amplifiers

The optional satellite audio system consists of:

- Satellite Digital Audio Receiver System (SDARS) module (located behind the RH luggage compartment trim panel)
- 

- Satellite radio antenna
- Satellite radio antenna cable (part of the luggage compartment lid harness)

Refer to the Owner's Literature for complete audio system operating controls and functions.

#### Antenna

The antenna system consists of:

- Antenna mast
- Antenna base cover
- Antenna base and cable
- Antenna lead-in cable

The radio antenna uses a 2-piece coaxial cable to connect the Audio Control Module (ACM) to the antenna. The front antenna lead-in cable is connected to the ACM and has an in-line connector behind the glove compartment.

The satellite antenna (if equipped) consists of a trunk-mounted antenna capable of receiving digital satellite audio signals. A one-piece antenna cable connects the satellite antenna to the SDARS module. The cable is part of the luggage compartment lid harness and cannot be replaced separately.

## DIAGNOSIS AND TESTING

### Information and Entertainment System

#### Special Tool(s)

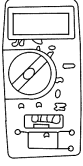
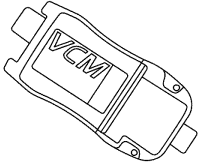
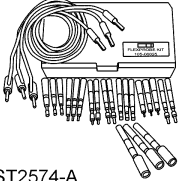
 <p>ST1137-A</p>	73III Automotive Meter 105-R0057 or equivalent
 <p>ST2834-A</p>	Vehicle Communication Module (VCM) and Integrated Diagnostic System (IDS) software with appropriate hardware, or equivalent scan tool
 <p>ST2574-A</p>	Flex Probe Kit 105-R025C or equivalent

#### Principles of Operation

**NOTE:** The smart junction box (SJB) is also known as the generic electronic module (GEM).

#### Audio Control Module (ACM)

The ACM can be powered up when the ignition is in the ON or ACC position. When on, the ACM directs audio signals to the speakers through separate positive and negative circuits for each of the audio channels. The ACM provides internal circuit protection for shorts to ground, shorts to voltage, or shorts between any output circuits.

#### Noise Suppression Equipment

The radio interference suppression equipment reduces interference transmitted through the speakers by the engine ignition and electrical systems.

#### Antenna

The antenna is a fixed mast antenna mounted on the exterior of the vehicle. The antenna receives both AM and FM radio waves. The audio signals are then sent to the ACM through the antenna cables.

#### Subwoofers

The subwoofer speakers on the 500-watt system are located in the front doors and are powered by individual amplifiers located on each speaker. In addition to these subwoofer speakers, the 1000-watt system includes an enclosure with 2 subwoofer speakers powered by 2 amplifiers, each. The enable/clip circuit carries out 2 functions: to turn on the subwoofer amplifier, and to monitor an overload condition to the subwoofer amplifier. In the event of an overload, the ACM clips the audio output signal to the subwoofer amplifier (heard as distortion).

#### Satellite Audio

The satellite audio system consists of the satellite digital audio receiver system (SDARS) module, a satellite radio antenna, and antenna cable (part of the decklid harness). The satellite radio antenna receives digital audio signals and sends them to the SDARS module, where the signals are converted and sent to the ACM. The wake-up signal for the SDARS module is sent from the ACM through the medium speed controller area network (MS-CAN).

#### Audio Input Jack

The audio input jack allows for a portable MP3 player to be connected to the vehicle audio system. When a portable MP3 player is connected, audio from the MP3 player can be played through the vehicle speakers.

#### Navigation

The navigation module is integrated in the ACM and controls the operation and the interface between the user, the vehicle subsystems, and the external components. The navigation module communicates with other vehicle systems via the MS-CAN and can be diagnosed with a scan tool. When installing a new ACM, programmable module installation (PMI) is required.

The vehicle navigation system guides the user to a pre-entered destination. A navigation map DVD stored in the navigation module sends route calculation data to the ACM. The ACM audibly and visually instructs the user of the maneuvers required to arrive at the destination entered.

## DIAGNOSIS AND TESTING (Continued)

In order to calculate the initial vehicle position, the global positioning system (GPS) antenna is used to track several available satellites simultaneously. The GPS antenna only receives data and does not communicate with the satellites. A gyroscope, integral to the navigation module, monitors the pitch and yaw of the vehicle created during cornering or turning. Vehicle speed and reverse signals received through the MS-CAN are also used to detect vehicle speed and direction changes.

### Network Communication

The following audio system components communicate via the MS-CAN:

- ACM
- Navigation ACM
- SDARS module

The following messages are utilized by the audio system:

Message	Transmitting Module	Receiving Module(s)	Audio System Function
Ignition Switch Position	Smart junction box (SJB)	ACM SDARS module	Indicates ignition switch position for power-up/shut-down.
Backlight Dimmer	SJB	ACM	Controls the backlight intensity, based on the position of the dimmer switch.
Transmission Gear Selected	Instrument cluster	ACM	For navigation system, this signal is used for more accurate navigation tracking.
Vehicle Speed	Instrument cluster	ACM	Used by the ACM for the speed-compensated volume function.
Wheel Speed Data	Instrument cluster	ACM	For navigation system, this signal is used for more accurate navigation tracking.

### Inspection and Verification

1. Verify the customer concern.
2. Visually inspect for obvious signs of mechanical or electrical damage.

#### Visual Inspection Chart

Mechanical	Electrical
<ul style="list-style-type: none"> <li>• Audio control module (ACM)</li> <li>• Antenna or antenna cable(s)</li> <li>• Global positioning system (GPS) antenna</li> <li>• Navigation map DVD</li> <li>• Satellite radio antenna</li> <li>• Speakers, mounting/speaker cones</li> <li>• Radio ignition interference capacitors, radio frequency interference suppression bond, and radio receiver hood bonding strap</li> </ul>	<ul style="list-style-type: none"> <li>• Smart junction box (SJB) fuse(s):               <ul style="list-style-type: none"> <li>— 6 (5A) (ACM)</li> <li>— 20 (10A) (ACM)</li> </ul> </li> <li>• Bussed electrical center (BEC) fuse(s):               <ul style="list-style-type: none"> <li>— 6 (30A) (luggage compartment amplifiers)</li> <li>— 9 (30A) (luggage compartment amplifiers)</li> <li>— 16 (30A) (door amplifiers)</li> <li>— 56 (20A) (ACM, SDARS module)</li> </ul> </li> <li>• Wiring, terminals or connectors</li> </ul>

3. If an obvious cause for an observed or reported concern is found, correct the cause (if possible) before proceeding to the next step.

4. **NOTE:** Make sure to use the latest scan tool software release.

If the cause is not visually evident, connect the scan tool to the data link connector (DLC).

5. **NOTE:** The vehicle communication module (VCM) LED prove-out confirms power and ground from the DLC are provided to the VCM.

If the scan tool does not communicate with the VCM:

- Check the VCM connection to the vehicle.
- Check the scan tool connection to the VCM.
- Refer to Section 418-00, No Power To The Scan Tool, to diagnose no communication with the scan tool.

6. If the scan tool does not communicate with the vehicle:

- Verify the ignition key is in the ON position.
- Verify the scan tool operation with a known good vehicle.
- Refer to Section 418-00 to diagnose no response from the PCM.

## DIAGNOSIS AND TESTING (Continued)

7. Carry out the network test.
  - If the scan tool responds with no communication for one or more modules, refer to Section 418-00.
  - If the network test passes, retrieve and record the continuous memory DTCs.
8. Clear the continuous DTCs and carry out the self-test diagnostics for the ACM.
9. If the DTCs retrieved are related to the concern, go to DTC Charts in this section.
10. If no DTCs related to the concern are retrieved, go to the Speaker Walk-Around Test, the Audio Control Module Self-Diagnostic Mode — Without Navigation, the Audio Control Module (ACM) Self-Diagnostic Mode — Navigation, or the Satellite Audio Bezel Diagnostic Test.

### Speaker Walk-Around Test

**NOTE:** To enter the speaker walk-around test or ACM self-diagnostic mode, the audio system must be on and in radio tuner mode.

1. To enter the speaker walk-around test, simultaneously press and hold the preset buttons 3 and 6.
2. The speaker walk-around test stops at each speaker and applies sound to each speaker for about 1-2 seconds. Each speaker is tested and displayed on the ACM in the following sequence: RF, LF, LR, RR, and SUBWOOFER.
3. To exit the speaker walk-around test, turn the key to OFF, turn the audio system off, or press preset button 1 for diagnostics.

### Audio Control Module (ACM) Self-Diagnostic Mode — Without Navigation

**NOTE:** To enter the ACM self-diagnostic mode, the audio system must be on and in radio tuner mode.

1. To enter the following tests, press the desired preset button while in the speaker walk-around test.
2. The self-diagnostic mode has the following functions available:
  - Preset button 1 = On-Demand Self-Test. This button runs the on-demand self-test.
    - Pressing the MENU DOWN button allows scrolling of any DTCs found during the test while in this menu.

- Preset button 2 = Display Continuous DTCs. This button enables viewing of any continuous DTCs that have been logged.
    - Pressing the MENU UP button allows scrolling of any DTCs while in this menu.
    - While continuous DTCs are being displayed, pressing the EJECT button will clear all present DTCs. The key must be cycled OFF, then ON, to permanently clear DTCs.
  - Preset button 3 = Signal Strength Test. This button displays the signal strength.
  - Preset button 4 = Software Version Display. This button displays the ACM software version.
    - Pressing the MENU UP button allows scrolling of all audio subsystem software versions while in this menu.
  - Preset button 5 = Display Test. This test illuminates all the display segments for 5 seconds, then either turns all segments off or indicates DISPLAY TEST on the screen.
  - Preset button 6 = Configuration Status. This button enables ACM configuration status.
    - Pressing the MENU UP button displays the ACM part number while in this menu.
3. To exit the self-diagnostic mode, turn the key to OFF or turn the audio system off.
  4. If the concern remains and the fault is not detected, GO to [Symptom Chart](#).

### Audio Control Module (ACM) Self-Diagnostic Mode — Navigation

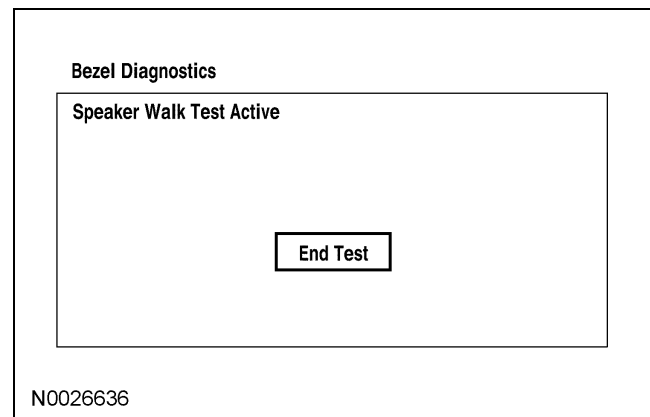

## DIAGNOSIS AND TESTING (Continued)

- To enter the self-diagnostic mode, press “End Test” during the speaker walk-around test.

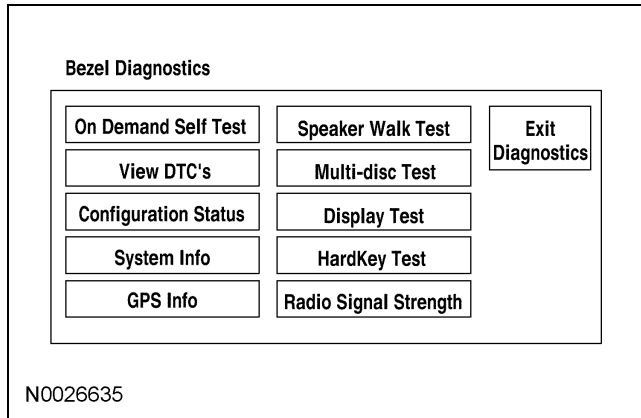

- The following diagnostic modes are available using the on-screen buttons:
  - “On Demand Self Test” — provides internal self-test diagnostics and displays all the DTCs resulting from the self-test.
  - “View DTC's” — provides a list of all the DTCs currently stored in memory.
  - “Configuration Status” — displays the current unit configuration.
  - “System Info” — provides the navigation module part number and software information.
  - “GPS Info” — provides satellite information and vehicle current information.
  - “Speaker Walk Test” — performs a speaker walk-around test.
  - “Multi-disc Test” — performs a test of the CD player mechanism.
  - “Display Test” — allows the screen colors to be checked, and allows individual touch sectors of the display screen to be tested.
  - “Hardkey Test” — checks the operation of any ACM button.
  - “Radio Signal Strength” — performs a test of the AM/FM antenna signal.
- To exit the self-diagnostic mode, turn the audio system off, turn the key to OFF, or press “Exit Diagnostics”.
- If the concern remains and the fault is not detected, GO to [Symptom Chart](#) to continue diagnostics.

### Satellite Audio Bezel Diagnostic Test

**NOTE:** To enter the satellite audio bezel diagnostic test, the audio system must be on and in SAT mode.

- To enter the satellite audio bezel diagnostic test, simultaneously press and hold the AUX button and preset button 2 (except navigation), or the SOUND button and preset button 1 (navigation).
- Upon entering the self-test, the audio system produces 2 continuously alternating tones of different pitch, one for the right channel, then one for the left.
- The test continues by displaying any DTCs currently present. If no DTCs are present, NO DTCs will be displayed. If there are DTCs present, the ACM will auto-scroll through the list of active DTCs.
- Historical DTCs can be viewed by pressing the AUX button and preset button 2 (except navigation), or the SOUND button and preset button 1 (navigation) simultaneously while in the active DTC mode.
  - If any DTCs are present, pressing the AUX button and preset button 2 (except navigation), or the SOUND button and preset button 1 (navigation) will prompt CLEAR DTCs? on the ACM.
  - To clear historical DTCs, press preset buttons 1, 2, and 3 consecutively within 4 seconds.
  - To exit historical DTCs (with or without clearing DTCs), press the AUX button and preset button 2 (except navigation), or the SOUND button and preset button 1 (navigation) simultaneously.
- If no historical DTCs are present, pressing the AUX button and preset button 2 (except navigation), or the SOUND button and preset button 1 (navigation) simultaneously while in active DTC mode will display the DLP software version.
- To exit the satellite audio bezel diagnostic test, press the AUX button and preset button 2 (except navigation), or the SOUND button and preset button 1 (navigation) simultaneously while the DLP software version is displayed, or turn the audio system off.

**DIAGNOSIS AND TESTING (Continued)**

7. If the concern remains and the fault is not detected, GO to [Symptom Chart](#).

**DTC Charts****Audio Control Module (ACM) DTC Chart**

<b>DTC</b>	<b>Description</b>	<b>Action</b>
B1117	Audio Steering Wheel Button Stuck	DTC is not applicable. The vehicle is not equipped with steering wheel controls. DISREGARD the DTC. CLEAR the DTCs. REPEAT the self-test.
B1119	Audio Disc DVD Player Thermal Shutdown	The audio control module (ACM) was over temperature. Audio operation will resume after the ACM cools. This is normal operation. CLEAR the DTCs.
B1136	Audio Steering Wheel Switch #2 Circuit Failure	DTC is not applicable. The vehicle is not equipped with steering wheel controls. DISREGARD the DTC. CLEAR the DTCs. REPEAT the self-test.
B1140	Map Disk Invalid	REMOVE the map DVD and CLEAN it. INSPECT for scratches, fingerprints, or damage, and REPAIR as necessary. VERIFY a valid map DVD is being used. If no concern is found, INSERT a known good map DVD. REPEAT the self-test. <ul style="list-style-type: none"> <li>• If the system operates correctly, the concern was caused by a damaged or invalid map DVD.</li> <li>• If DTC B1140 is retrieved again, INSTALL a new ACM. REFER to Audio Control Module (ACM) in this section. TEST the system for normal operation.</li> </ul>
B1318	Battery Voltage Low	CLEAR the DTCs. TEST the charging system. REFER to Section 414-00. <ul style="list-style-type: none"> <li>• If the charging system is OK, the DTC was set by a previous low voltage condition. No concern is found at this time.</li> <li>• If the charging system is not OK, REFER to Section 414-00 to diagnose the low battery voltage condition.</li> </ul>
B1342	ECU is Faulted	CLEAR the DTCs. REPEAT the self-test. If DTC B1342 is retrieved again, INSTALL a new ACM. REFER to Audio Control Module (ACM) in this section. TEST the system for normal operation.
B2103	Antenna Not Connected	<a href="#">GO to Pinpoint Test A.</a>
B2204	GPS Antenna Connection Open or Short	<a href="#">GO to Pinpoint Test H.</a>
B2274	Phone Transceiver Active Circuit Failure	DTC is not applicable. The vehicle is not equipped with cellular phone functionality. DISREGARD the DTC. CLEAR the DTCs. REPEAT the self-test.
B2384	Audio Reverse Aid Mute Input Ckt Failure	DTC is not applicable. The vehicle is not equipped with parking aid. DISREGARD the DTC. CLEAR the DTCs. REPEAT the self-test.

**DIAGNOSIS AND TESTING (Continued)****Audio Control Module (ACM) DTC Chart (Continued)**

<b>DTC</b>	<b>Description</b>	<b>Action</b>
B2404	Audio Steering Wheel Switch Circuit Failure	DTC is not applicable. The vehicle is not equipped with steering wheel controls. DISREGARD the DTC. CLEAR the DTCs. REPEAT the self-test.
B2405	Audio Disc CD Player Thermal Shutdown Fault	The ACM was over temperature. Audio operation will resume after the ACM cools. This is normal operation. CLEAR the DTCs.
B2406	Audio Disc CD Player Internal Fault	<b>NOTE:</b> DTC B1342 will also be set. CLEAR the DTCs. REPEAT the self-test. If DTC B2406 or B1342 is retrieved again, INSTALL a new ACM. REFER to Audio Control Module (ACM) in this section. TEST the system for normal operation.
B2477	Module Configuration Failure	REFER to Section 418-01.
B2633	Driver-Front Microphone Circuit Failure	DTC is not applicable. The vehicle is not equipped with voice-activated navigation. DISREGARD the DTC. CLEAR the DTCs. REPEAT the self-test.
B2656	DVD (Digital Versatile Disk) Error	<b>NOTE:</b> DTC B1342 will also be set. CLEAR the DTCs. REPEAT the self-test. If DTC B2656 or B1342 is retrieved again, INSTALL a new ACM. REFER to Audio Control Module (ACM) in this section. TEST the system for normal operation.
B2924	Audio Button Stuck	For the navigation ACM, <a href="#">GO to Pinpoint Test K</a> . For all others, VERIFY no ACM buttons are stuck and that no ACM button was pressed during the self-test. CLEAR the DTCs. REPEAT the self-test. If DTC B2924 is retrieved again, INSTALL a new ACM. REFER to Audio Control Module (ACM) in this section. TEST the system for normal operation.
B2965	Audio System Speaker Circuit Fault	<a href="#">GO to Pinpoint Test B</a> .
C1992	Vehicle Speed Circuit Failure	DISREGARD the DTC. CLEAR the DTCs. REPEAT the self-test.
P0812	Reverse Input Circuit	DISREGARD the DTC. CLEAR the DTCs. REPEAT the self-test.

**DIAGNOSIS AND TESTING (Continued)****Audio Control Module (ACM) DTC Chart (Continued)**

<b>DTC</b>	<b>Description</b>	<b>Action</b>
U0140	Lost Communication With Body Control Module (GEM)	<p><b>NOTE:</b> If no related concern is currently present, disregard the DTC.</p> <p><b>NOTE:</b> Diagnose DTC B1318 (if present) before diagnosing this DTC.</p> <p>VERIFY the operation of the vehicle illumination and the accessory delay.</p> <ul style="list-style-type: none"> <li>— If the vehicle illumination or accessory delay does not operate correctly, REFER to Section 413-00 (illumination) or Section 501-11 (accessory delay).</li> <li>— If the vehicle illumination and accessory delay operate correctly, CLEAR the DTC. REPEAT the self-test. If DTC U0140 sets again, INSTALL a new ACM. REFER to Audio Control Module (ACM) in this section. TEST the system for normal operation.</li> </ul>
U0155	Lost Communication With Instrument Panel Cluster (IC) Control Module	<p><b>NOTE:</b> If no related concern is currently present, disregard the DTC.</p> <p>If the speed sensitive volume does not operate correctly, <a href="#">GO to Pinpoint Test M</a>.</p> <p>If the navigation is inaccurate, <a href="#">GO to Pinpoint Test L</a>.</p>
U0159	Lost Communication With Parking Assist Control Module (PAM)	DTC is not applicable. The vehicle is not equipped with parking aid. DISREGARD the DTC. CLEAR the DTCs. REPEAT the self-test.
U0193	Lost Communication With Digital Audio Control Module (SDARS)	<p><b>NOTE:</b> If no related concern is currently present, disregard the DTC.</p> <p><a href="#">GO to Pinpoint Test F</a>.</p>
U0196	Lost Communication With Entertainment Control Module - Rear (AUX)	DTC is not applicable. The vehicle is not equipped with rear audio controls. DISREGARD the DTC. CLEAR the DTCs. REPEAT the self-test.
U0197	Lost Communication With Telephone Control Module	DTC is not applicable. The vehicle is not equipped with cellular phone functionality. DISREGARD the DTC. CLEAR the DTCs. REPEAT the self-test.
U0238	Lost Communication With Digital Audio Control Module "D" (DSP)	DTC is not applicable. The vehicle is not equipped with a DSP module. DISREGARD the DTC. CLEAR the DTCs. REPEAT the self-test.
U0249	Lost Communication With Entertainment Control Module - Rear "B" (RCU)	DTC is not applicable. The vehicle is not equipped with rear audio controls. DISREGARD the DTC. CLEAR the DTCs. REPEAT the self-test.

**DIAGNOSIS AND TESTING (Continued)****Audio Control Module (ACM) DTC Chart (Continued)**

<b>DTC</b>	<b>Description</b>	<b>Action</b>
U2050	No Application Present	CONFIGURE the ACM. REFER to Section 418-01 to carry out programmable module installation (PMI). CLEAR the DTCs. REPEAT the self-test. If DTC U2050 is retrieved again, INSTALL a new ACM. REFER to Audio Control Module (ACM) in this section. TEST the system for normal operation.
U2051	One or More Calibration Files Missing/Corrupt	CONFIGURE the ACM. REFER to Section 418-01 to carry out PMI. CLEAR the DTCs. REPEAT the self-test. If DTC U2051 is retrieved again, INSTALL a new ACM. REFER to Audio Control Module (ACM) in this section. TEST the system for normal operation.
U2473	Unexpected Vehicle Speed (VSS)	<a href="#">GO to Pinpoint Test L.</a>

**Satellite Digital Audio Receiver System (SDARS) Module DTC Chart**

**NOTE:** While running the satellite audio bezel diagnostic test, DTCs contain the characters "SAT" after the 5-digit DTC.

<b>DTC</b>	<b>Description</b>	<b>Action</b>
B1031	SDARS Satellite Antenna Open	<a href="#">GO to Pinpoint Test G.</a>
B1032	SDARS Satellite Antenna Short	<a href="#">GO to Pinpoint Test G.</a>
B1318	Battery Voltage Low	CLEAR the DTCs. TEST the charging system. REFER to Section 414-00. <ul style="list-style-type: none"> <li>• If the charging system is OK, the DTC was set by a previous low voltage condition. No concern is found at this time.</li> <li>• If the charging system is not OK, REFER to Section 414-00 to diagnose the low battery voltage condition.</li> </ul>
B1342	ECU is Faulted	CLEAR the DTCs. REPEAT the self-test. If DTC B1342 is retrieved again, INSTALL a new satellite digital audio receiver system (SDARS) module. REFER to Satellite Digital Audio Receiver System (SDARS) Module in this section. TEST the system for normal operation after the repair.
B2477	Module Configuration Failure	REFER to Section 418-01.
U0184	Lost Communication With Radio (ACM)	<b>NOTE:</b> If no related concern is currently present, disregard the DTC. <a href="#">GO to Pinpoint Test F.</a>
U0196	Lost Communication With Entertainment Control Module - Rear (AUX)	DTC is not applicable. The vehicle is not equipped with rear audio controls. DISREGARD the DTC. CLEAR the DTCs. REPEAT the self-test.
U0197	Lost Communication With Telephone Control Module	DTC is not applicable. The vehicle is not equipped with cellular phone functionality. DISREGARD the DTC. CLEAR the DTCs. REPEAT the self-test.

**DIAGNOSIS AND TESTING (Continued)****Satellite Digital Audio Receiver System (SDARS) Module DTC Chart (Continued)**

<b>DTC</b>	<b>Description</b>	<b>Action</b>
U0249	Lost Communication With Entertainment Control Module - Rear "B" (RCU)	DTC is not applicable. The vehicle is not equipped with rear audio controls. DISREGARD the DTC. CLEAR the DTCs. REPEAT the self-test.
U2050	No Application Present	CONFIGURE the SDARS module. REFER to Section 418-01 to carry out PMI. CLEAR the DTCs. REPEAT the self-test. If DTC U2050 is retrieved again, INSTALL a new SDARS module. REFER to Satellite Digital Audio Receiver System (SDARS) Module in this section. TEST the system for normal operation.

**Symptom Chart****Symptom Chart — Audio System**

<b>Condition</b>	<b>Possible Sources</b>	<b>Action</b>
<ul style="list-style-type: none"> <li>No communication with the audio control module (ACM)</li> </ul>	<ul style="list-style-type: none"> <li>Fuse</li> <li>Wiring, terminals or connectors</li> <li>Audio control module (ACM)</li> </ul>	<ul style="list-style-type: none"> <li>REFER to Section 418-00.</li> </ul>
<ul style="list-style-type: none"> <li>No communication with the satellite digital audio receiver system (SDARS) module</li> </ul>	<ul style="list-style-type: none"> <li>Fuse</li> <li>Wiring, terminals or connectors</li> <li>ACM</li> </ul>	<ul style="list-style-type: none"> <li>REFER to Section 418-00.</li> </ul>
<ul style="list-style-type: none"> <li>The satellite audio is inoperative/does not operate correctly</li> </ul>	<ul style="list-style-type: none"> <li>Subscription status</li> <li>Wiring, terminals or connectors</li> <li>SDARS module</li> <li>ACM</li> </ul>	<ul style="list-style-type: none"> <li>GO to Pinpoint Test F.</li> </ul>
<ul style="list-style-type: none"> <li>The ACM backlighting does not operate correctly</li> </ul>	<ul style="list-style-type: none"> <li>Wiring, terminals or connectors</li> <li>ACM</li> </ul>	<ul style="list-style-type: none"> <li>REFER to Section 413-00.</li> </ul>
<ul style="list-style-type: none"> <li>Poor reception — AM/FM</li> </ul>	<ul style="list-style-type: none"> <li>Antenna</li> <li>Antenna cable(s)</li> <li>Charging system</li> <li>Ignition system</li> <li>Noise suppression equipment</li> <li>ACM</li> </ul>	<ul style="list-style-type: none"> <li>GO to Pinpoint Test A.</li> </ul>
<ul style="list-style-type: none"> <li>Poor reception — satellite audio</li> </ul>	<ul style="list-style-type: none"> <li>Obstructions to the line of sight</li> <li>Satellite radio antenna</li> <li>Satellite radio antenna cable</li> <li>SDARS module</li> </ul>	<ul style="list-style-type: none"> <li>DRIVE the vehicle to an open area and TEST the reception. <ul style="list-style-type: none"> <li>If the reception is OK, INFORM the customer that the satellite signal can be affected by obstructions to the satellite antenna line of sight.</li> <li>If the reception is not OK, GO to Pinpoint Test G.</li> </ul> </li> <li>GO to Pinpoint Test G.</li> </ul>

**DIAGNOSIS AND TESTING (Continued)****Symptom Chart — Audio System (Continued)**

Condition	Possible Sources	Action
<ul style="list-style-type: none"> <li>Continuous seek/scan in AM/FM</li> </ul>	<ul style="list-style-type: none"> <li>RDS/PTY function setting</li> <li>Antenna cable(s)</li> <li>Noise suppression equipment</li> <li>Antenna</li> <li>ACM</li> </ul>	<ul style="list-style-type: none"> <li>VERIFY the RDS/PTY function is set to ALL. REFER to the Owner's Literature. SCAN for a good channel. <ul style="list-style-type: none"> <li>If a good channel is found, the cause of the concern was that no channel in the selected category was found. The system is OK.</li> <li>If a good channel is not found, GO to Pinpoint Test A.</li> </ul> </li> <li>GO to Pinpoint Test A.</li> </ul>
<ul style="list-style-type: none"> <li>Poor quality/distorted/no sound from one or more speakers (not all speakers) — except subwoofers</li> </ul>	<ul style="list-style-type: none"> <li>Wiring, terminals or connectors</li> <li>Speaker</li> <li>ACM</li> </ul>	<ul style="list-style-type: none"> <li>GO to Pinpoint Test B.</li> </ul>
<ul style="list-style-type: none"> <li>Poor quality/distorted/no sound from all speakers</li> </ul>	<ul style="list-style-type: none"> <li>Wiring, terminals or connectors</li> <li>ACM</li> </ul>	<ul style="list-style-type: none"> <li>With the key in any position except START, MEASURE the voltage between the ACM C290d-15, circuit 1000 (RD/BK), harness side and ground. <ul style="list-style-type: none"> <li>If any voltage is present, REPAIR the circuit. TEST the system for normal operation.</li> <li>If no voltage is present, INSTALL a new ACM. REFER to Audio Control Module (ACM) in this section. TEST the system for normal operation.</li> </ul> </li> </ul>
<ul style="list-style-type: none"> <li>The subwoofer is inoperative/does not operate correctly — front subwoofers</li> </ul>	<ul style="list-style-type: none"> <li>Fuse</li> <li>Wiring, terminals or connectors</li> <li>Subwoofer amplifier</li> <li>Front subwoofer</li> <li>ACM</li> </ul>	<ul style="list-style-type: none"> <li>GO to Pinpoint Test C.</li> </ul>
<ul style="list-style-type: none"> <li>The subwoofer is inoperative/does not operate correctly — rear subwoofers</li> </ul>	<ul style="list-style-type: none"> <li>Fuse</li> <li>Wiring, terminals or connectors</li> <li>Subwoofer amplifier</li> <li>Rear subwoofer</li> <li>ACM</li> </ul>	<ul style="list-style-type: none"> <li>GO to Pinpoint Test D.</li> </ul>
<ul style="list-style-type: none"> <li>Loud popping sound when cycling the ignition switch</li> </ul>	<ul style="list-style-type: none"> <li>Fuse</li> <li>Wiring, terminals or connectors</li> <li>Subwoofer amplifier</li> <li>ACM</li> </ul>	<ul style="list-style-type: none"> <li>GO to Pinpoint Test E.</li> </ul>

**DIAGNOSIS AND TESTING (Continued)****Symptom Chart — Audio System (Continued)**

Condition	Possible Sources	Action
<ul style="list-style-type: none"> <li>The speed sensitive volume does not operate correctly.</li> </ul>	<ul style="list-style-type: none"> <li>Speed sensitive volume setting</li> <li>Vehicle speed sensor (VSS) signal concern</li> <li>ACM</li> </ul>	<ul style="list-style-type: none"> <li><a href="#">GO to Pinpoint Test M.</a></li> </ul>
<ul style="list-style-type: none"> <li>The audio input jack is inoperative/does not operate correctly</li> </ul>	<ul style="list-style-type: none"> <li>Wiring, terminals or connectors</li> <li>Audio input jack</li> <li>ACM</li> </ul>	<ul style="list-style-type: none"> <li><a href="#">GO to Pinpoint Test N.</a></li> </ul>

**Symptom Chart — Navigation**

Condition	Possible Sources	Action
<ul style="list-style-type: none"> <li>No global positioning system (GPS) antenna signal</li> </ul>	<ul style="list-style-type: none"> <li>GPS antenna</li> <li>Audio control module (ACM)</li> </ul>	<ul style="list-style-type: none"> <li><a href="#">GO to Pinpoint Test H.</a></li> </ul>
<ul style="list-style-type: none"> <li>Navigation screen only displays Dearborn, Michigan</li> </ul>	<ul style="list-style-type: none"> <li>GPS antenna</li> </ul>	<ul style="list-style-type: none"> <li><a href="#">GO to Pinpoint Test L.</a></li> </ul>
<ul style="list-style-type: none"> <li>The position cursor is inaccurate</li> </ul>	<ul style="list-style-type: none"> <li>Wheel pulse data concern</li> <li>ACM</li> </ul>	<ul style="list-style-type: none"> <li><a href="#">GO to Pinpoint Test L.</a></li> </ul>
<ul style="list-style-type: none"> <li>The audible switch feedback is inoperative</li> </ul>	<ul style="list-style-type: none"> <li>Audible switch feedback setting</li> <li>ACM</li> </ul>	<ul style="list-style-type: none"> <li><a href="#">GO to Pinpoint Test I.</a></li> </ul>
<ul style="list-style-type: none"> <li>The voice guidance is inoperative/does not operate correctly</li> </ul>	<ul style="list-style-type: none"> <li>Incorrect system setting</li> <li>ACM</li> </ul>	<ul style="list-style-type: none"> <li><a href="#">GO to Pinpoint Test J.</a></li> </ul>
<ul style="list-style-type: none"> <li>The display screen is inoperative</li> </ul>	<ul style="list-style-type: none"> <li>ACM</li> </ul>	<ul style="list-style-type: none"> <li>VERIFY the operation of the AM/FM audio system. <ul style="list-style-type: none"> <li>If the AM/FM system does not operate correctly, <a href="#">GO to Symptom Chart — Audio System.</a></li> <li>If the AM/FM system operates correctly, INSTALL a new ACM. REFER to Audio Control Module (ACM) in this section. TEST the system for normal operation.</li> </ul> </li> </ul>

**DIAGNOSIS AND TESTING (Continued)****Symptom Chart — Navigation (Continued)**

Condition	Possible Sources	Action
<ul style="list-style-type: none"> <li>Unable to read map disc</li> </ul>	<ul style="list-style-type: none"> <li>Map DVD</li> <li>ACM</li> </ul>	<ul style="list-style-type: none"> <li>REMOVE the map DVD and CLEAN it. INSPECT for scratches, fingerprints, or damage, and REPAIR as necessary. VERIFY a valid map DVD is being used. If no concern is found, INSERT a known good map DVD. TEST the system. <ul style="list-style-type: none"> <li>If the system operates correctly, the concern was caused by a damaged or inoperable map DVD.</li> <li>If the system does not operate correctly, INSTALL a new ACM. REFER to Audio Control Module (ACM) in this section. TEST the system for normal operation.</li> </ul> </li> </ul>
<ul style="list-style-type: none"> <li>The screen does not open/close</li> </ul>	<ul style="list-style-type: none"> <li>Trim panel interference</li> <li>ACM</li> </ul>	<ul style="list-style-type: none"> <li>INSPECT the instrument panel center trim panel for interference with the navigation screen and REPAIR as necessary. If no interference is found, INSTALL a new ACM. REFER to Audio Control Module (ACM) in this section. TEST the system for normal operation.</li> </ul>

**Pinpoint Tests****Pinpoint Test A: Poor Reception — AM/FM****Normal Operation**

The noise suppression equipment reduces interference transmitted through the speakers by the engine ignition and electrical systems.

- DTC B2103 (Antenna Not Connected) — sets when the signal strength is less than a pre-determined value during the “antenna connected test” portion of the audio control module (ACM) self-test. This DTC may not set, even if there is an open in the antenna coaxial cable; however, if it does set, the antenna circuit can be isolated for diagnosis.

**This pinpoint test is intended to diagnose the following:**

- Antenna
- Antenna cable(s)
- Charging system
- Ignition system
- Noise suppression equipment
- ACM

**DIAGNOSIS AND TESTING (Continued)****PINPOINT TEST A: POOR RECEPTION — AM/FM**

Test Step		Result / Action to Take
<b>A1</b>	<b>REVIEW THE DTCs</b>	<b>Yes</b> GO to <b>A7</b> .  <b>No</b> GO to <b>A2</b> .
	<ul style="list-style-type: none"> <li>Review the DTCs from the ACM self-test.</li> <li><b>Is DTC B2103 present?</b></li> </ul>	
<b>A2</b>	<b>CHECK THE AUDIO SYSTEM RECEPTION</b>	<b>Yes</b> GO to <b>A3</b> .  <b>No</b> GO to <b>A7</b> .
	<ul style="list-style-type: none"> <li>Check the ACM signal reception with the engine running, and with the engine off.</li> <li><b>Does the poor reception only occur with the engine running?</b></li> </ul>	
<b>A3</b>	<b>CHECK THE SUPPRESSION EQUIPMENT/MOUNTING AND CONNECTING CIRCUITS</b>	<b>Yes</b> GO to <b>A4</b> .  <b>No</b> CLEAN, SECURE, or INSTALL new suppression equipment as necessary. TEST the system for normal operation.
	<ul style="list-style-type: none"> <li>Ignition OFF.</li> <li>Check all necessary suppression equipment and the radio frequency interference suppression bond.</li> <li><b>NOTE:</b> The capacitor mounting points are used to complete the electrical circuit and must be mounted securely to clean surfaces.</li> <li>Check the mounting and connecting circuits of the radio interference capacitor for integrity, cleanliness, and metal-to-metal contact.</li> <li><b>Are the connections clean, secure, and in metal-to-metal contact?</b></li> </ul>	
<b>A4</b>	<b>CHECK THE RADIO INTERFERENCE CAPACITOR</b>	<b>Yes</b> INSTALL a new radio interference capacitor. TEST the system for normal operation.  <b>No</b> INSTALL the original radio interference capacitor. GO to <b>A5</b> .
	<ul style="list-style-type: none"> <li>Check the operation of the radio interference capacitor by installing a known good component.</li> <li>Start the vehicle.</li> <li>Operate the audio system in radio tuner mode.</li> <li><b>Is the reception OK?</b></li> </ul>	
<b>A5</b>	<b>CHECK THE GENERATOR</b>	<b>Yes</b> INSTALL a new generator. REFER to Section 414-02. TEST the system for normal operation.  <b>No</b> TURN the key to OFF. CONNECT the voltage regulator. GO to <b>A6</b> .
	<ul style="list-style-type: none"> <li>Ignition OFF.</li> <li>Check the generator by disconnecting the voltage regulator.</li> <li>Start the vehicle.</li> <li>Operate the audio system in radio tuner mode.</li> <li><b>Is the reception OK?</b></li> </ul>	
<b>A6</b>	<b>CHECK THE IGNITION CIRCUITS</b>	<b>Yes</b> GO to <b>A10</b> .  <b>No</b> REPAIR the ignition system as necessary. TEST the system for normal operation.
	<ul style="list-style-type: none"> <li>Check the ignition circuits for correct routing, ground, and integrity of connections.</li> <li>Check the spark plugs and ignition coils.</li> <li><b>Are the ignition components OK?</b></li> </ul>	
<b>A7</b>	<b>CHECK THE ANTENNA GROUND</b>	<b>Yes</b> GO to <b>A9</b> .  <b>No</b> GO to <b>A8</b> .
	<ul style="list-style-type: none"> <li>Ignition OFF.</li> <li>Measure the resistance between the antenna base and the battery ground cable.</li> <li><b>Is the resistance less than 5 ohms?</b></li> </ul>	
<b>A8</b>	<b>CHECK THE ANTENNA CABLE CONNECTIONS</b>	<b>Yes</b> GO to <b>A9</b> .  <b>No</b> CLEAN and SECURE the antenna connections as necessary. CLEAR the DTCs. REPEAT the self-test.
	<ul style="list-style-type: none"> <li>Check the antenna connections, including the extension cable.</li> <li>Check to make sure the antenna is securely mounted to the vehicle body at ground points.</li> <li><b>Are the connections clean, secure, and in metal-to-metal contact?</b></li> </ul>	

(Continued)

**DIAGNOSIS AND TESTING (Continued)**

**PINPOINT TEST A: POOR RECEPTION — AM/FM (Continued)**

Test Step		Result / Action to Take
<b>A9</b>	<b>SUBSTITUTE THE ANTENNA</b>	<p><b>Yes</b> INSTALL a new antenna. CLEAR the DTCs. REPEAT the self-test.</p> <p><b>No</b> TURN the key to OFF. INSTALL the original antenna. GO to <b>A10</b>.</p>
	<ul style="list-style-type: none"> <li>Substitute a known good antenna.</li> <li>Ignition ON.</li> <li>Operate the audio system in radio tuner mode.</li> <li><b>Is the reception OK?</b></li> </ul>	
<b>A10</b>	<b>SUBSTITUTE THE ANTENNA CABLE</b>	<p><b>Yes</b> INSTALL a new antenna cable. REFER to Antenna Lead-In Cable in this section. CLEAR the DTCs. REPEAT the self-test.</p> <p><b>No</b> TURN the key to OFF. INSTALL the original antenna cable. GO to <b>A11</b>.</p>
	<ul style="list-style-type: none"> <li>Substitute a known good antenna cable.</li> <li>Ignition ON.</li> <li>Operate the audio system in radio tuner mode.</li> <li><b>Is the reception OK?</b></li> </ul>	
<b>A11</b>	<b>SUBSTITUTE THE ACM</b>	<p><b>Yes</b> SEND the original ACM to an authorized audio system repair facility. TEST the system for normal operation after the repair.</p> <p><b>No</b> INSTALL the original ACM. GO to <b>A12</b>.</p>
	<ul style="list-style-type: none"> <li>Substitute a known good ACM.</li> <li>Start the vehicle.</li> <li>Operate the audio system in radio tuner mode.</li> <li><b>Is the reception OK?</b></li> </ul>	
<b>A12</b>	<b>REPOSITION THE COMPONENTS</b>	<p><b>Yes</b> Permanently REPOSITION the components as needed. TEST the system for normal operation.</p> <p><b>No</b> GROUND various parts of the vehicle to the frame using a jumper cable (for example: engine, fenders, quarter panels, stone deflectors, body sheet metal). When the concern is corrected, PROVIDE a permanent ground where necessary. TEST the system for normal operation.</p>
	<ul style="list-style-type: none"> <li>Determine if the concern can be corrected by repositioning the antenna extension cable, speaker circuits, or ACM power feed circuits away from other circuits and brackets.</li> <li>Start the vehicle.</li> <li>Operate the audio system in radio tuner mode.</li> <li><b>Is the reception OK?</b></li> </ul>	

**Pinpoint Test B: Poor Quality/Distorted/No Sound from One or More Speakers (Not All Speakers) — Except Subwoofers**

Refer to [Wiring Diagrams Cell 130, Audio System/Navigation for schematic and connector information.](#)

**Normal Operation**

The audio control module (ACM) directs the audio signals to the speakers through separate positive and negative circuits for each of the audio channels. The ACM provides internal circuit protection for shorts to ground, shorts to voltage, or shorts between any output circuits.

For the navigation system, if the voice guidance setting is set to zero rather than to off, it may appear that the front speakers intermittently produce no sound. Make sure the voice guidance setting is not set to zero before addressing a concern with the front speakers.

- DTC B2965 (Audio System Speaker Circuit Fault) — sets when an open, a short to ground, or a short to voltage is detected on the front door or rear door speaker circuits. The ACM checks these circuits during the self-test, and checks them every 500 milliseconds during normal operation.

**This pinpoint test is intended to diagnose the following:**

- Wiring, terminals or connectors
- Speaker
- ACM

**DIAGNOSIS AND TESTING (Continued)**

**PINPOINT TEST B: POOR QUALITY/DISTORTED/NO SOUND FROM ONE OR MORE SPEAKERS (NOT ALL SPEAKERS) — EXCEPT SUBWOOFERS**

**NOTICE:** Use the correct probe adapter(s) when making measurements. Failure to use the correct probe adapter(s) may damage the connector.

Test Step		Result / Action to Take															
<b>B1</b>	<p><b>CHECK FOR OTHER CONCERNS</b></p> <ul style="list-style-type: none"> <li>Ignition OFF.</li> <li>Remove the trim panel for the suspect speaker. Refer to Section 501-05.</li> <li>Remove the speaker and check for:                             <ul style="list-style-type: none"> <li>connector integrity.</li> <li>debris in the speaker cone.</li> </ul> </li> <li>Install the speaker, but leave the trim panel off.</li> <li>Ignition ON.</li> <li>Operate the audio system in radio tuner mode.</li> <li>Observe the operation of the suspect speaker.</li> <li><b>Is the speaker sound OK?</b></li> </ul>	<p><b>Yes</b> INSPECT the trim panel and REPAIR as necessary. TEST the system for normal operation.</p> <p><b>No</b> GO to <b>B2</b>.</p>															
<b>B2</b>	<p><b>CHECK THE SPEAKER CIRCUITS FOR VOLTAGE</b></p> <ul style="list-style-type: none"> <li>Ignition OFF.</li> <li>Disconnect: Suspect Speaker.</li> <li>Ignition ON.</li> <li>Operate the audio system in radio tuner mode.</li> <li>Measure the AC voltage between the suspect speaker pin 1 and pin 2, harness side as follows:</li> </ul> <table border="1" data-bbox="142 905 969 1264"> <thead> <tr> <th>Suspect Speaker</th> <th>Connector-Pin/ Circuit</th> <th>Connector-Pin/ Circuit</th> </tr> </thead> <tbody> <tr> <td>LH front</td> <td>C523-1 1723 (OG/LG)</td> <td>C523-2 1722 (LB/WH)</td> </tr> <tr> <td>RH front</td> <td>C612-1 1778 (WH/LG)</td> <td>C612-2 1777 (DG/OG)</td> </tr> <tr> <td>LH rear</td> <td>C484-1 1726 (GY/LB)</td> <td>C484-2 1725 (TN/YE)</td> </tr> <tr> <td>RH rear</td> <td>C485-1 1781 (OG/RD)</td> <td>C485-2 1780 (BN/PK)</td> </tr> </tbody> </table> <ul style="list-style-type: none"> <li><b>Is an alternating AC voltage present?</b></li> </ul>		Suspect Speaker	Connector-Pin/ Circuit	Connector-Pin/ Circuit	LH front	C523-1 1723 (OG/LG)	C523-2 1722 (LB/WH)	RH front	C612-1 1778 (WH/LG)	C612-2 1777 (DG/OG)	LH rear	C484-1 1726 (GY/LB)	C484-2 1725 (TN/YE)	RH rear	C485-1 1781 (OG/RD)	C485-2 1780 (BN/PK)
Suspect Speaker	Connector-Pin/ Circuit	Connector-Pin/ Circuit															
LH front	C523-1 1723 (OG/LG)	C523-2 1722 (LB/WH)															
RH front	C612-1 1778 (WH/LG)	C612-2 1777 (DG/OG)															
LH rear	C484-1 1726 (GY/LB)	C484-2 1725 (TN/YE)															
RH rear	C485-1 1781 (OG/RD)	C485-2 1780 (BN/PK)															
<b>B3</b>	<p><b>CHECK THE SPEAKER CIRCUITS FOR A SHORT TO VOLTAGE</b></p> <ul style="list-style-type: none"> <li>Ignition OFF.</li> <li>Disconnect: ACM C290d.</li> <li>Ignition ON.</li> <li>Measure the voltage between the suspect speaker, harness side and ground as follows:</li> </ul> <table border="1" data-bbox="142 1514 969 1843"> <thead> <tr> <th>Suspect Speaker</th> <th>Connector-Pin</th> <th>Circuit</th> </tr> </thead> <tbody> <tr> <td>LH front</td> <td>C523-1 C523-2</td> <td>1723 (OG/LG) 1722 (LB/WH)</td> </tr> <tr> <td>RH front</td> <td>C612-1 C612-2</td> <td>1778 (WH/LG) 1777 (DG/OG)</td> </tr> <tr> <td>LH rear</td> <td>C484-1 C484-2</td> <td>1726 (GY/LB) 1725 (TN/YE)</td> </tr> <tr> <td>RH rear</td> <td>C485-1 C485-2</td> <td>1781 (OG/RD) 1780 (BN/PK)</td> </tr> </tbody> </table> <ul style="list-style-type: none"> <li><b>Is any voltage present?</b></li> </ul>	Suspect Speaker	Connector-Pin	Circuit	LH front	C523-1 C523-2	1723 (OG/LG) 1722 (LB/WH)	RH front	C612-1 C612-2	1778 (WH/LG) 1777 (DG/OG)	LH rear	C484-1 C484-2	1726 (GY/LB) 1725 (TN/YE)	RH rear	C485-1 C485-2	1781 (OG/RD) 1780 (BN/PK)	<p><b>Yes</b> REPAIR the circuit in question. CLEAR the DTCs. REPEAT the speaker walk-around test.</p> <p><b>No</b> GO to <b>B4</b>.</p>
Suspect Speaker	Connector-Pin	Circuit															
LH front	C523-1 C523-2	1723 (OG/LG) 1722 (LB/WH)															
RH front	C612-1 C612-2	1778 (WH/LG) 1777 (DG/OG)															
LH rear	C484-1 C484-2	1726 (GY/LB) 1725 (TN/YE)															
RH rear	C485-1 C485-2	1781 (OG/RD) 1780 (BN/PK)															

(Continued)

**DIAGNOSIS AND TESTING (Continued)**

**PINPOINT TEST B: POOR QUALITY/DISTORTED/NO SOUND FROM ONE OR MORE SPEAKERS (NOT ALL SPEAKERS) — EXCEPT SUBWOOFERS (Continued)**

Test Step		Result / Action to Take																																					
<b>B4</b>	<p><b>CHECK THE SPEAKER CIRCUITS FOR AN OPEN OR SHORT TO GROUND</b></p> <ul style="list-style-type: none"> <li>Ignition OFF.</li> <li>Measure the resistance between the suspect speaker, harness side and the ACM, harness side; and between the suspect speaker, harness side and ground as follows:</li> </ul> <table border="1"> <thead> <tr> <th>Suspect Speaker</th> <th>Speaker Connector-Pin</th> <th>ACM Connector-Pin</th> <th>Circuit</th> </tr> </thead> <tbody> <tr> <td>LH front</td> <td>C523-1</td> <td>C290d-8</td> <td>1723 (OG/LG)</td> </tr> <tr> <td>LH front</td> <td>C523-2</td> <td>C290d-21</td> <td>1722 (LB/WH)</td> </tr> <tr> <td>RH front</td> <td>C612-1</td> <td>C290d-11</td> <td>1778 (WH/LG)</td> </tr> <tr> <td>RH front</td> <td>C612-2</td> <td>C290d-12</td> <td>1777 (DG/OG)</td> </tr> <tr> <td>LH rear</td> <td>C484-1</td> <td>C290d-9</td> <td>1726 (GY/LB)</td> </tr> <tr> <td>LH rear</td> <td>C484-2</td> <td>C290d-22</td> <td>1725 (TN/YE)</td> </tr> <tr> <td>RH rear</td> <td>C485-1</td> <td>C290d-10</td> <td>1781 (OG/RD)</td> </tr> <tr> <td>RH rear</td> <td>C485-2</td> <td>C290d-23</td> <td>1780 (BN/PK)</td> </tr> </tbody> </table> <ul style="list-style-type: none"> <li>Is the resistance less than 5 ohms between the suspect speaker and the ACM, and greater than 10,000 ohms between the suspect speaker and ground?</li> </ul>	Suspect Speaker	Speaker Connector-Pin	ACM Connector-Pin	Circuit	LH front	C523-1	C290d-8	1723 (OG/LG)	LH front	C523-2	C290d-21	1722 (LB/WH)	RH front	C612-1	C290d-11	1778 (WH/LG)	RH front	C612-2	C290d-12	1777 (DG/OG)	LH rear	C484-1	C290d-9	1726 (GY/LB)	LH rear	C484-2	C290d-22	1725 (TN/YE)	RH rear	C485-1	C290d-10	1781 (OG/RD)	RH rear	C485-2	C290d-23	1780 (BN/PK)	<p><b>Yes</b> GO to <b>B5</b>.</p> <p><b>No</b> REPAIR the circuit in question. CLEAR the DTCs. REPEAT the speaker walk-around test.</p>	
Suspect Speaker	Speaker Connector-Pin	ACM Connector-Pin	Circuit																																				
LH front	C523-1	C290d-8	1723 (OG/LG)																																				
LH front	C523-2	C290d-21	1722 (LB/WH)																																				
RH front	C612-1	C290d-11	1778 (WH/LG)																																				
RH front	C612-2	C290d-12	1777 (DG/OG)																																				
LH rear	C484-1	C290d-9	1726 (GY/LB)																																				
LH rear	C484-2	C290d-22	1725 (TN/YE)																																				
RH rear	C485-1	C290d-10	1781 (OG/RD)																																				
RH rear	C485-2	C290d-23	1780 (BN/PK)																																				
<b>B5</b>	<p><b>CHECK FOR CORRECT ACM OPERATION</b></p> <ul style="list-style-type: none"> <li>Disconnect the ACM connectors.</li> <li>Check for:                             <ul style="list-style-type: none"> <li>corrosion</li> <li>damaged pins</li> <li>pushed-out pins</li> </ul> </li> <li>Connect the ACM connectors and make sure they seat correctly.</li> <li>Operate the system and determine if the concern is still present.</li> <li>Is the concern still present?</li> </ul>	<p><b>Yes</b> INSTALL a new ACM. REFER to Audio Control Module (ACM) in this section. TEST the system for normal operation.</p> <p><b>No</b> The system is operating correctly at this time. The concern may have been caused by a loose or corroded connector. CLEAR the DTCs. REPEAT the self-test.</p>																																					

**Pinpoint Test C: The Subwoofer is Inoperative/Does Not Operate Correctly — Front Subwoofer**

Refer to [Wiring Diagrams Cell 130, Audio System/Navigation for schematic and connector information.](#)

**Normal Operation**

The front subwoofers are powered by a separate subwoofer amplifier for each subwoofer speaker. The enable/clip circuit 173 (DG/VT) carries out 2 functions: to turn on the subwoofer amplifiers, and monitor an overload condition to the subwoofer amplifier. In the event of an overload, the audio control module (ACM) clips the audio output signal to the subwoofer amplifiers (heard as distortion). The front subwoofer amplifiers receive voltage through circuit 829 (WH/VT), and ground through circuit 1204 (BK/OG).

**This pinpoint test is intended to diagnose the following:**

- Fuse
- Wiring, terminals or connectors
- Subwoofer amplifier
- Subwoofer
- ACM

**DIAGNOSIS AND TESTING (Continued)**

**PINPOINT TEST C: THE SUBWOOFER IS INOPERATIVE/DOES NOT OPERATE CORRECTLY — FRONT SUBWOOFER**

**NOTICE:** Use the correct probe adapter(s) when making measurements. Failure to use the correct probe adapter(s) may damage the connector.

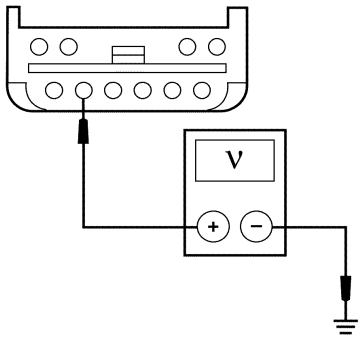
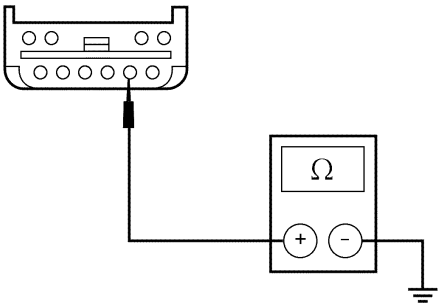
Test Step		Result / Action to Take
<b>C1</b>	<p><b>CHECK CIRCUIT 829 (WH/VT) FOR VOLTAGE</b></p> <ul style="list-style-type: none"> <li>Ignition OFF.</li> <li>Disconnect: Left Front Subwoofer Amplifier C2993a and Right Front Subwoofer Amplifier C2994a.</li> <li>Measure the voltage between the left front subwoofer amplifier C2993a-5, circuit 829 (WH/VT), harness side and ground; and between the right front subwoofer amplifier C2994a-5, circuit 829 (WH/VT), harness side and ground.</li> </ul>  <p>A0021366</p> <ul style="list-style-type: none"> <li>Are the voltages greater than 10 volts?</li> </ul>	<p><b>Yes</b> GO to C2.</p> <p><b>No</b> VERIFY the bussed electrical center (BEC) fuse 16 (30A) is OK. If OK, REPAIR the circuit in question. TEST the system for normal operation.</p>
<b>C2</b>	<p><b>CHECK CIRCUIT 1204 (BK/OG) FOR AN OPEN</b></p> <ul style="list-style-type: none"> <li>Measure the resistance between the left front subwoofer amplifier C2993a-2, circuit 1204 (BK/OG), harness side and ground; and between the right front subwoofer amplifier C2994a-2, circuit 1204 (BK/OG), harness side and ground.</li> </ul>  <p>GK5794-A</p> <ul style="list-style-type: none"> <li>Are the resistances less than 5 ohms?</li> </ul>	<p><b>Yes</b> GO to C3.</p> <p><b>No</b> REPAIR the circuit in question. TEST the system for normal operation.</p>
<b>C3</b>	<p><b>CHECK CIRCUIT 173 (DG/VT) FOR VOLTAGE</b></p> <ul style="list-style-type: none"> <li>Ignition ON.</li> <li>Operate the audio system in radio tuner mode.</li> </ul>	

(Continued)

**DIAGNOSIS AND TESTING (Continued)**

**PINPOINT TEST C: THE SUBWOOFER IS INOPERATIVE/DOES NOT OPERATE CORRECTLY — FRONT SUBWOOFER (Continued)**

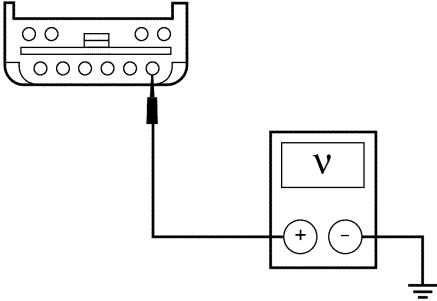
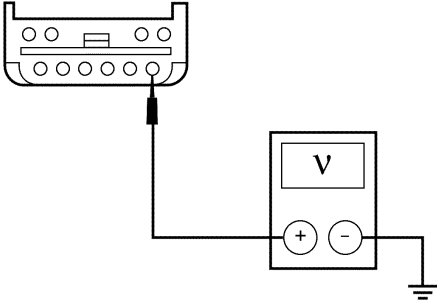
Test Step		Result / Action to Take
<b>C3</b>	<b>CHECK CIRCUIT 173 (DG/VT) FOR VOLTAGE (Continued)</b>	
<ul style="list-style-type: none"> <li>Measure the voltage between the left front subwoofer amplifier <b>C2993a-1</b>, circuit 173 (DG/VT), harness side and ground; and between the right front subwoofer amplifier <b>C2994a-1</b>, circuit 173 (DG/VT), harness side and ground.</li> </ul>  <p style="text-align: center;">GK4985-A</p> <ul style="list-style-type: none"> <li>Is the voltage between 3.8 and 6.7 volts at both amplifiers?</li> </ul>		<p><b>Yes</b> GO to <b>C6</b>.</p> <p><b>No</b> If the voltage is incorrect at one amplifier only, REPAIR the circuit in question. TEST the system for normal operation. If the voltage is incorrect at both amplifiers, GO to <b>C4</b>.</p>
<b>C4</b>	<b>CHECK CIRCUIT 173 (DG/VT) FOR A SHORT TO VOLTAGE</b>	
<ul style="list-style-type: none"> <li>Ignition OFF.</li> <li>Disconnect: ACM <b>C290b</b>.</li> <li>Ignition ON.</li> <li>Measure the voltage between the left front subwoofer amplifier <b>C2993a-1</b>, circuit 173 (DG/VT), harness side and ground.</li> </ul>  <p style="text-align: center;">GK4985-A</p> <ul style="list-style-type: none"> <li>Is any voltage present?</li> </ul>		<p><b>Yes</b> REPAIR the circuit. TEST the system for normal operation.</p> <p><b>No</b> GO to <b>C5</b>.</p>
<b>C5</b>	<b>CHECK CIRCUIT 173 (DG/VT) FOR AN OPEN OR SHORT TO GROUND</b>	
<ul style="list-style-type: none"> <li>Ignition OFF.</li> <li>Measure the resistance between the left front subwoofer amplifier <b>C2993a-1</b>, circuit 173 (DG/VT), harness side and the ACM <b>C290b-4</b>, circuit 173 (DG/VT); and between the left front subwoofer amplifier <b>C2993a-1</b>, circuit 173 (DG/VT), harness side and ground.</li> <li>Is the resistance less than 5 ohms between the left front subwoofer amplifier and the ACM, and greater than 10,000 ohms between the left front subwoofer amplifier and ground?</li> </ul>		<p><b>Yes</b> GO to <b>C13</b>.</p> <p><b>No</b> REPAIR the circuit. TEST the system for normal operation.</p>
<b>C6</b>	<b>CHECK THE AUDIO SIGNALS TO THE FRONT SUBWOOFER AMPLIFIER</b>	
<ul style="list-style-type: none"> <li>Operate the audio system in radio tuner mode.</li> </ul>		

(Continued)

**DIAGNOSIS AND TESTING (Continued)**

**PINPOINT TEST C: THE SUBWOOFER IS INOPERATIVE/DOES NOT OPERATE CORRECTLY — FRONT SUBWOOFER (Continued)**

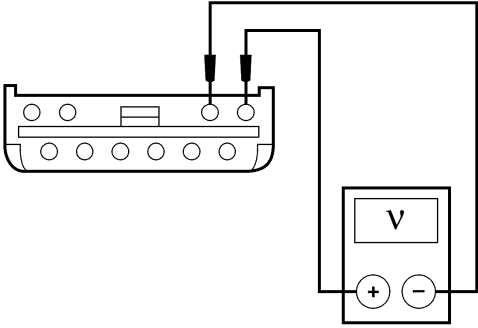
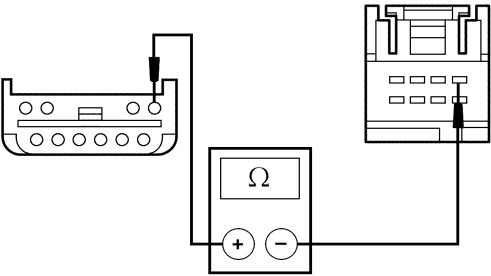
	Test Step	Result / Action to Take
<p><b>C6</b></p>	<p><b>CHECK THE AUDIO SIGNALS TO THE FRONT SUBWOOFER AMPLIFIER (Continued)</b></p> <ul style="list-style-type: none"> <li>Measure the AC voltage between the left front subwoofer amplifier C2993a-7, circuit 167 (BN/OG), harness side and the left front subwoofer amplifier C2993a-8, circuit 168 (RD/BK), harness side; and between the right front subwoofer amplifier C2994a-7, circuit 167 (BN/OG), harness side and the right front subwoofer amplifier C2994a-8, circuit 168 (RD/BK), harness side.</li> </ul>  <p>A0057176</p> <ul style="list-style-type: none"> <li>Is a fluctuating AC voltage present at both amplifiers?</li> </ul>	<p><b>Yes</b> GO to C10.</p> <p><b>No</b> If the voltage is incorrect at one amplifier only, GO to C7. If the voltage is incorrect at both amplifiers, GO to C8.</p>
<p><b>C7</b></p>	<p><b>CHECK CIRCUIT 167 (BN/OG) FOR AN OPEN</b></p> <p><b>NOTE:</b> Carry out this step only for the inoperative subwoofer.</p> <ul style="list-style-type: none"> <li>Ignition OFF.</li> <li>Disconnect: ACM C290b.</li> <li>Measure the resistance between the left front subwoofer amplifier C2993a-7, circuit 167 (BN/OG), harness side and the ACM C290b-1, circuit 167 (BN/OG), harness side; or between the right front subwoofer amplifier C2993a-7, circuit 167 (BN/OG), harness side and the ACM C290b-1, circuit 167 (BN/OG), harness side.</li> </ul>  <p>N0056195</p> <ul style="list-style-type: none"> <li>Is the resistance less than 5 ohms?</li> </ul>	<p><b>Yes</b> REPAIR circuit 168 (RD/BK). TEST the system for normal operation.</p> <p><b>No</b> REPAIR circuit 167 (BN/OG). TEST the system for normal operation.</p>
<p><b>C8</b></p>	<p><b>CHECK CIRCUITS 167 (BN/OG) AND 168 (RD/BK) FOR A SHORT TO VOLTAGE</b></p> <ul style="list-style-type: none"> <li>Ignition OFF.</li> <li>Disconnect: ACM C290b.</li> <li>Ignition ON.</li> </ul>	

(Continued)

**DIAGNOSIS AND TESTING (Continued)**

**PINPOINT TEST C: THE SUBWOOFER IS INOPERATIVE/DOES NOT OPERATE CORRECTLY — FRONT SUBWOOFER (Continued)**

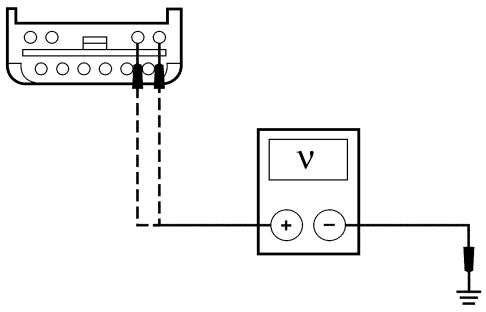
Test Step		Result / Action to Take									
<b>C8</b>	<p><b>CHECK CIRCUITS 167 (BN/OG) AND 168 (RD/BK) FOR A SHORT TO VOLTAGE (Continued)</b></p> <ul style="list-style-type: none"> <li>Measure the voltage between the left front subwoofer amplifier <a href="#">C2993a-7</a>, circuit 167 (BN/OG), harness side and ground; and between the left front subwoofer amplifier <a href="#">C2993a-8</a>, circuit 168 (RD/BK), harness side and ground.</li> </ul>  <p>N0035293</p> <ul style="list-style-type: none"> <li>Is any voltage present?</li> </ul>	<p><b>Yes</b> REPAIR the circuit in question. TEST the system for normal operation.</p> <p><b>No</b> GO to <a href="#">C9</a>.</p>									
<b>C9</b>	<p><b>CHECK CIRCUITS 167 (BN/OG) AND 168 (RD/BK) FOR AN OPEN OR SHORT TO GROUND</b></p> <ul style="list-style-type: none"> <li>Ignition OFF.</li> <li>Measure the resistance between the left front subwoofer amplifier, harness side and the ACM, harness side; and between the left front subwoofer amplifier, harness side and ground as follows:</li> </ul> <table border="1" data-bbox="142 1123 971 1312"> <thead> <tr> <th>Subwoofer Amplifier Connector-Pin</th> <th>ACM Connector-Pin</th> <th>Circuit</th> </tr> </thead> <tbody> <tr> <td><a href="#">C2993a-7</a></td> <td><a href="#">C290b-1</a></td> <td>167 (BN/OG)</td> </tr> <tr> <td><a href="#">C2993a-8</a></td> <td><a href="#">C290b-2</a></td> <td>168 (RD/BK)</td> </tr> </tbody> </table> <ul style="list-style-type: none"> <li>Is the resistance less than 5 ohms between the left front subwoofer amplifier and the ACM, and greater than 10,000 ohms between the left front subwoofer amplifier and ground?</li> </ul>	Subwoofer Amplifier Connector-Pin	ACM Connector-Pin	Circuit	<a href="#">C2993a-7</a>	<a href="#">C290b-1</a>	167 (BN/OG)	<a href="#">C2993a-8</a>	<a href="#">C290b-2</a>	168 (RD/BK)	<p><b>Yes</b> GO to <a href="#">C13</a>.</p> <p><b>No</b> REPAIR the circuit in question. TEST the system for normal operation.</p>
Subwoofer Amplifier Connector-Pin	ACM Connector-Pin	Circuit									
<a href="#">C2993a-7</a>	<a href="#">C290b-1</a>	167 (BN/OG)									
<a href="#">C2993a-8</a>	<a href="#">C290b-2</a>	168 (RD/BK)									
<b>C10</b>	<p><b>CHECK THE AUDIO CIRCUITS TO THE SUSPECT FRONT SUBWOOFER</b></p> <ul style="list-style-type: none"> <li>Ignition OFF.</li> <li>Connect: Left Front Subwoofer Amplifier <a href="#">C2993a</a> and Right Front Subwoofer Amplifier <a href="#">C2994a</a>.</li> <li>Disconnect: Left Front Subwoofer <a href="#">C536</a> or Right Front Subwoofer <a href="#">C628</a>.</li> <li>Ignition ON.</li> <li>Operate the audio system in radio tuner mode.</li> <li>Measure the AC voltage between the suspect front subwoofer circuits, harness side as follows:</li> </ul>										

(Continued)

**DIAGNOSIS AND TESTING (Continued)**

**PINPOINT TEST C: THE SUBWOOFER IS INOPERATIVE/DOES NOT OPERATE CORRECTLY — FRONT SUBWOOFER (Continued)**

Test Step			Result / Action to Take	
<b>C10</b>	<b>CHECK THE AUDIO CIRCUITS TO THE SUSPECT FRONT SUBWOOFER (Continued)</b>		<p><b>Yes</b> INSTALL a new subwoofer for the suspect subwoofer. REFER to Subwoofer Speaker in this section. TEST the system for normal operation.</p> <p><b>No</b> GO to <b>C11</b>.</p>	
	<b>Suspect Subwoofer</b>	<b>Subwoofer Connector-Pin/Circuit</b>		<b>Subwoofer Connector-Pin/Circuit</b>
	Left front	C536-1 804 (OG/LG)		C536-2 813 (LB/WH)
	Left front	C536-3 820 (DB/YE)		C536-4 819 (LG/WH)
	Right front	C628-1 805 (WH/LG)		C628-2 811 (DG/OG)
	Right front	C628-3 816 (LG/VT)	C628-4 815 (LG/OG)	
	<ul style="list-style-type: none"> <li>Is a fluctuating AC voltage present?</li> </ul>			
<b>C11</b>	<b>CHECK THE AUDIO CIRCUITS TO THE SUSPECT SUBWOOFER FOR A SHORT TO VOLTAGE</b>		<p><b>Yes</b> REPAIR the circuit in question. TEST the system for normal operation.</p> <p><b>No</b> GO to <b>C12</b>.</p>	
	<ul style="list-style-type: none"> <li>Ignition OFF.</li> <li>Disconnect: Left Front Subwoofer Amplifier C2993a and Right Front Subwoofer Amplifier C2994a.</li> <li>Ignition ON.</li> <li>Measure the voltage between the suspect front subwoofer, harness side and ground as follows:</li> </ul>			
	<b>Suspect Subwoofer</b>	<b>Subwoofer Connector-Pin</b>		<b>Circuit</b>
	Left front	C536-1		804 (OG/LG)
		C536-2		813 (LB/WH)
		C536-3	820 (DB/YE)	
		C536-4	819 (LG/WH)	
	Right front	C628-1	805 (WH/LG)	
		C628-2	811 (DG/OG)	
		C628-3	816 (LG/VT)	
		C628-4	815 (LG/OG)	
	<ul style="list-style-type: none"> <li>Is any voltage present?</li> </ul>			
<b>C12</b>	<b>CHECK THE AUDIO CIRCUITS TO THE SUSPECT SUBWOOFER FOR AN OPEN OR SHORT TO GROUND</b>		<p><b>Yes</b> REPAIR the circuit in question. TEST the system for normal operation.</p> <p><b>No</b> GO to <b>C12</b>.</p>	
	<ul style="list-style-type: none"> <li>Ignition OFF.</li> <li>Measure the resistance between the suspect front subwoofer, harness side and the front amplifier, harness side; and between the suspect front subwoofer, harness side and ground as follows:</li> </ul>			

(Continued)

**DIAGNOSIS AND TESTING (Continued)**

**PINPOINT TEST C: THE SUBWOOFER IS INOPERATIVE/DOES NOT OPERATE CORRECTLY — FRONT SUBWOOFER (Continued)**

Test Step				Result / Action to Take
<b>C12</b>	<b>CHECK THE AUDIO CIRCUITS TO THE SUSPECT SUBWOOFER FOR AN OPEN OR SHORT TO GROUND (Continued)</b>			
	<b>Suspect Subwoofer</b>	<b>Subwoofer Connector-Pin</b>	<b>ACM Connector-Pin</b>	
	Left front	C536-1	C2993b-1	804 (OG/LG)
		C536-2	C2993b-2	813 (LB/WH)
		C536-3	C2993b-3	820 (DB/YE)
		C536-4	C2993b-4	819 (LG/WH)
	Right front	C628-1	C2994b-1	805 (WH/LG)
		C628-2	C2994b-2	811 (DG/OG)
		C628-3	C2994b-3	816 (LG/VT)
		C628-4	C2994b-4	815 (LG/OG)
	<ul style="list-style-type: none"> <li>Is the resistance less than 5 ohms between the suspect front subwoofer and the front subwoofer amplifier, and greater than 10,000 ohms between the suspect front subwoofer and ground?</li> </ul>			<p><b>Yes</b> INSTALL a new front subwoofer amplifier for the suspect amplifier. REFER to Subwoofer Amplifier — Door in this section. TEST the system for normal operation.</p> <p><b>No</b> REPAIR the circuit in question. TEST the system for normal operation.</p>
<b>C13</b>	<b>CHECK FOR CORRECT ACM OPERATION</b>			
	<ul style="list-style-type: none"> <li>Disconnect the ACM connectors.</li> <li>Check for:                             <ul style="list-style-type: none"> <li>— corrosion</li> <li>— damaged pins</li> <li>— pushed-out pins</li> </ul> </li> <li>Connect the ACM connectors and make sure they seat correctly.</li> <li>Operate the system and determine if the concern is still present.</li> <li>Is the concern still present?</li> </ul>			

**Pinpoint Test D: The Subwoofer is Inoperative/Does Not Operate Correctly — Rear Subwoofer**

Refer to [Wiring Diagrams Cell 130, Audio System/Navigation for schematic and connector information.](#)

**Normal Operation**

The rear subwoofers are powered by a separate subwoofer amplifier for each subwoofer speaker. The enable/clip circuit 174 (GY/BK) carries out 2 functions: to turn on the subwoofer amplifiers, and monitor an overload condition to the subwoofer amplifiers. In the event of an overload, the audio control module (ACM) clips the audio output signal to the subwoofer amplifiers (heard as distortion). The rear subwoofer amplifiers receive voltage through circuit 828 (VT/LB) (right subwoofers) or circuit 830 (PK/YE) (left subwoofers), and ground through circuit 1204 (BK/OG).

**This pinpoint test is intended to diagnose the following:**

- Fuse
- Wiring, terminals or connectors
- Subwoofer amplifier
- Subwoofer
- ACM

**DIAGNOSIS AND TESTING (Continued)**

**PINPOINT TEST D: THE SUBWOOFER IS INOPERATIVE/DOES NOT OPERATE CORRECTLY — REAR SUBWOOFER**

**NOTICE:** Use the correct probe adapter(s) when making measurements. Failure to use the correct probe adapter(s) may damage the connector.

Test Step		Result / Action to Take	
<b>D1</b>	<b>CHECK CIRCUIT 828 (VT/LB) OR 830 (PK/YE) FOR VOLTAGE</b>	<p><b>Yes</b> GO to <b>D2</b>.</p> <p><b>No</b> VERIFY the bussed electrical center (BEC) fuse 6 (30A) or fuse 9 (30A) is OK. If OK, REPAIR the circuit in question. TEST the system for normal operation.</p>	
<ul style="list-style-type: none"> <li>Ignition OFF.</li> <li>Disconnect: Suspect Subwoofer Amplifier(s).</li> <li>Measure the voltage between the suspect subwoofer amplifier, harness side and ground as follows:</li> </ul>			
<b>Suspect Subwoofer Amplifier</b>	<b>Subwoofer Amplifier Connector-Pin</b>		<b>Circuit</b>
Left outboard	C4157a-5		830 (PK/YE)
Left inboard	C4158a-5		828 (VT/LB)
<ul style="list-style-type: none"> <li>Right inboard</li> <li>Right outboard</li> </ul>		<ul style="list-style-type: none"> <li>C4159a-5</li> <li>C4160a-5</li> </ul>	
<ul style="list-style-type: none"> <li>Is the voltage greater than 10 volts?</li> </ul>			
<b>D2</b>	<b>CHECK CIRCUIT 1204 (BK/OG) FOR AN OPEN</b>	<p><b>Yes</b> GO to <b>D3</b>.</p> <p><b>No</b> REPAIR the circuit in question. TEST the system for normal operation.</p>	
<ul style="list-style-type: none"> <li>Measure the resistance between the suspect subwoofer amplifier, harness side and ground as follows:</li> </ul>			
<b>Suspect Subwoofer Amplifier</b>	<b>Subwoofer Amplifier Connector-Pin</b>		<b>Circuit</b>
Left outboard	C4157a-2		1204 (BK/OG)
Left inboard	C4158a-2		1204 (BK/OG)
<ul style="list-style-type: none"> <li>Right inboard</li> <li>Right outboard</li> </ul>		<ul style="list-style-type: none"> <li>C4159a-2</li> <li>C4160a-2</li> </ul>	
<ul style="list-style-type: none"> <li>Is the resistance less than 5 ohms?</li> </ul>			
<b>D3</b>	<b>CHECK CIRCUIT 174 (GY/BK) FOR VOLTAGE</b>	<p><b>Yes</b> GO to <b>D6</b>.</p> <p><b>No</b> GO to <b>D4</b>.</p>	
<ul style="list-style-type: none"> <li>Ignition ON.</li> <li>Operate the audio system in radio tuner mode.</li> <li>Measure the voltage between the suspect subwoofer speaker, harness side and ground as follows:</li> </ul>			
<b>Suspect Subwoofer Amplifier</b>	<b>Subwoofer Amplifier Connector-Pin</b>		<b>Circuit</b>
Left outboard	C4157a-1		174 (GY/BK)
Left inboard	C4158a-1		174 (GY/BK)
<ul style="list-style-type: none"> <li>Right inboard</li> <li>Right outboard</li> </ul>		<ul style="list-style-type: none"> <li>C4159a-1</li> <li>C4160a-1</li> </ul>	
<ul style="list-style-type: none"> <li>Is the voltage between 3.8 and 6.7 volts?</li> </ul>			
<b>D4</b>	<b>CHECK CIRCUIT 174 (GY/BK) FOR A SHORT TO VOLTAGE</b>		
<ul style="list-style-type: none"> <li>Ignition OFF.</li> <li>Disconnect: ACM C290b.</li> <li>Ignition ON.</li> </ul>			

(Continued)

**DIAGNOSIS AND TESTING (Continued)**

**PINPOINT TEST D: THE SUBWOOFER IS INOPERATIVE/DOES NOT OPERATE CORRECTLY — REAR SUBWOOFER (Continued)**

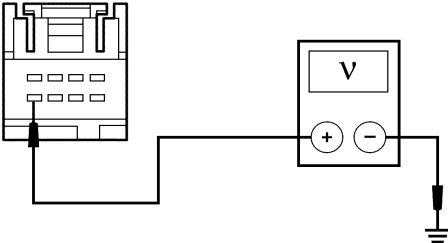
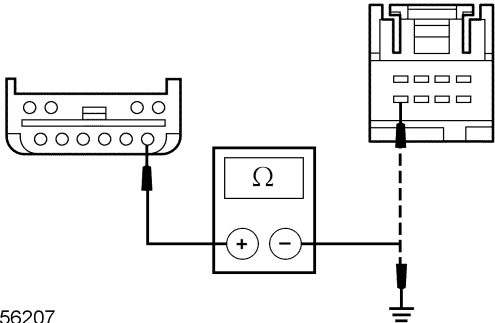
Test Step		Result / Action to Take
<b>D4</b>	<p><b>CHECK CIRCUIT 174 (GY/BK) FOR A SHORT TO VOLTAGE (Continued)</b></p> <ul style="list-style-type: none"> <li>Measure the voltage between the ACM <b>C290b-8</b>, circuit 174 (GY/BK), harness side and ground.</li> </ul>  <p>N0056196</p> <ul style="list-style-type: none"> <li><b>Is any voltage present?</b></li> </ul>	<p><b>Yes</b> REPAIR the circuit. TEST the system for normal operation.</p> <p><b>No</b> GO to <b>D5</b>.</p>
<b>D5</b>	<p><b>CHECK CIRCUIT 174 (GY/BK) FOR AN OPEN OR SHORT TO GROUND</b></p> <ul style="list-style-type: none"> <li>Ignition OFF.</li> <li>Measure the resistance between the suspect subwoofer amplifier pin 8, circuit 174 (GY/BK), harness side and the ACM <b>C290b-8</b>, circuit 174 (GY/BK), harness side; and between the suspect subwoofer speaker pin 8, circuit 174 (GY/BK), harness side and ground.</li> </ul>  <p>N0056207</p> <ul style="list-style-type: none"> <li><b>Is the resistance less than 5 ohms between the suspect subwoofer amplifier and the ACM, and greater than 10,000 ohms between the suspect subwoofer amplifier and ground?</b></li> </ul>	<p><b>Yes</b> GO to <b>D12</b>.</p> <p><b>No</b> REPAIR the circuit. TEST the system for normal operation.</p>
<b>D6</b>	<p><b>CHECK THE AUDIO SIGNALS TO THE SUSPECT SUBWOOFER AMPLIFIER</b></p> <ul style="list-style-type: none"> <li>Operate the audio system in radio tuner mode.</li> <li>Measure the AC voltage at the suspect subwoofer amplifier, harness side as follows:</li> </ul>	

(Continued)

**DIAGNOSIS AND TESTING (Continued)**

**PINPOINT TEST D: THE SUBWOOFER IS INOPERATIVE/DOES NOT OPERATE CORRECTLY — REAR SUBWOOFER (Continued)**

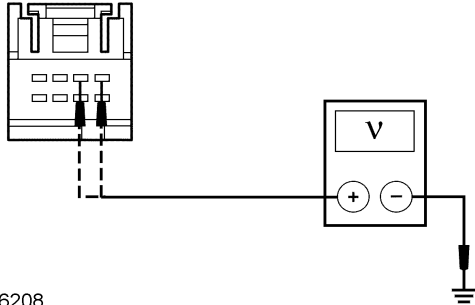
Test Step		Result / Action to Take															
<b>D6</b>	<b>CHECK THE AUDIO SIGNALS TO THE SUSPECT SUBWOOFER AMPLIFIER (Continued)</b>																
	<table border="1"> <thead> <tr> <th>Suspect Subwoofer Amplifier</th> <th>Subwoofer Amplifier Connector-Pin/ Circuit</th> <th>Subwoofer Amplifier Connector-Pin/ Circuit</th> </tr> </thead> <tbody> <tr> <td>Left outboard</td> <td>C4157a-7 179 (OG/RD)</td> <td>C4157a-8 176 (PK/LG)</td> </tr> <tr> <td>Left inboard</td> <td>C4158a-7 179 (OG/RD)</td> <td>C4158a-8 176 (PK/LG)</td> </tr> <tr> <td>Right inboard</td> <td>C4159a-7 179 (OG/RD)</td> <td>C4159a-8 176 (PK/LG)</td> </tr> <tr> <td>Right outboard</td> <td>C4160a-7 179 (OG/RD)</td> <td>C4160a-8 176 (PK/LG)</td> </tr> </tbody> </table> <ul style="list-style-type: none"> <li>Is a fluctuating AC voltage present?</li> </ul>	Suspect Subwoofer Amplifier	Subwoofer Amplifier Connector-Pin/ Circuit	Subwoofer Amplifier Connector-Pin/ Circuit	Left outboard	C4157a-7 179 (OG/RD)	C4157a-8 176 (PK/LG)	Left inboard	C4158a-7 179 (OG/RD)	C4158a-8 176 (PK/LG)	Right inboard	C4159a-7 179 (OG/RD)	C4159a-8 176 (PK/LG)	Right outboard	C4160a-7 179 (OG/RD)	C4160a-8 176 (PK/LG)	<p><b>Yes</b> GO to <b>D9</b>.</p> <p><b>No</b> GO to <b>D7</b>.</p>
Suspect Subwoofer Amplifier	Subwoofer Amplifier Connector-Pin/ Circuit	Subwoofer Amplifier Connector-Pin/ Circuit															
Left outboard	C4157a-7 179 (OG/RD)	C4157a-8 176 (PK/LG)															
Left inboard	C4158a-7 179 (OG/RD)	C4158a-8 176 (PK/LG)															
Right inboard	C4159a-7 179 (OG/RD)	C4159a-8 176 (PK/LG)															
Right outboard	C4160a-7 179 (OG/RD)	C4160a-8 176 (PK/LG)															
<b>D7</b>	<b>CHECK CIRCUITS 176 (PK/LG) AND 179 (OG/RD) FOR A SHORT TO VOLTAGE</b>																
	<ul style="list-style-type: none"> <li>Ignition OFF.</li> <li>Disconnect: ACM C290b.</li> <li>Ignition ON.</li> <li>Measure the voltage between the ACM C290b-5, circuit 176 (PK/LG), harness side and ground; and between the ACM C290b-6, circuit 179 (OG/RD), harness side and ground.</li> </ul>  <p>N0056208</p> <ul style="list-style-type: none"> <li>Is any voltage present?</li> </ul>	<p><b>Yes</b> REPAIR the circuit in question. TEST the system for normal operation.</p> <p><b>No</b> GO to <b>D8</b>.</p>															
<b>D8</b>	<b>CHECK CIRCUITS 176 (PK/LG) AND 179 (OG/RD) FOR AN OPEN OR SHORT TO GROUND</b>																
	<ul style="list-style-type: none"> <li>Ignition OFF.</li> <li>Measure the resistance between the suspect subwoofer amplifier, harness side and the ACM, harness side; and between the suspect subwoofer amplifier, harness side and ground as follows:</li> </ul>																

(Continued)

**DIAGNOSIS AND TESTING (Continued)**

**PINPOINT TEST D: THE SUBWOOFER IS INOPERATIVE/DOES NOT OPERATE CORRECTLY — REAR SUBWOOFER (Continued)**

Test Step				Result / Action to Take	
<b>D8</b>	<b>CHECK CIRCUITS 176 (PK/LG) AND 179 (OG/RD) FOR AN OPEN OR SHORT TO GROUND (Continued)</b>			<p><b>Yes</b> GO to <b>D12</b>.</p> <p><b>No</b> REPAIR the circuit in question. TEST the system for normal operation.</p>	
	<b>Suspect Subwoofer Amplifier</b>	<b>Subwoofer Amplifier Connector-Pin</b>	<b>ACM Connector-Pin</b>		<b>Circuit</b>
	Left outboard	C4157a-8	C290b-6		179 (OG/RD)
		C4157a-8	C290b-5		176 (PK/LG)
	Left inboard	C4158a-8	C290b-6		179 (OG/RD)
		C4158a-8	C290b-5		176 (PK/LG)
	Right inboard	C4159a-8	C290b-6	179 (OG/RD)	
		C4159a-8	C290b-5	176 (PK/LG)	
	Right outboard	C4160a-8	C290b-6	179 (OG/RD)	
		C4160a-8	C290b-5	176 (PK/LG)	
	<ul style="list-style-type: none"> <li>Is the resistance less than 5 ohms between the suspect subwoofer amplifier and the ACM, and greater than 10,000 ohms between the suspect subwoofer amplifier and ground?</li> </ul>				
<b>D9</b>	<b>CHECK THE AUDIO CIRCUITS TO THE SUSPECT REAR SUBWOOFER</b>			<p><b>Yes</b> INSTALL a new subwoofer for the suspect subwoofer. REFER to Subwoofer Speaker in this section. TEST the system for normal operation.</p> <p><b>No</b> GO to <b>D10</b>.</p>	
	<ul style="list-style-type: none"> <li>Ignition OFF.</li> <li>Connect: Suspect Subwoofer Amplifier.</li> <li>Disconnect: Suspect Rear Subwoofer.</li> <li>Ignition ON.</li> <li>Operate the audio system in radio tuner mode.</li> <li>Measure the AC voltage between the suspect rear subwoofer circuits, harness side as follows:</li> </ul>				
	<b>Suspect Subwoofer</b>	<b>Subwoofer Connector-Pin/ Circuit</b>	<b>Subwoofer Connector-Pin/ Circuit</b>		
	Left outboard	C4161-1 800 (GY/LB)	C4161-2 801 (TN/YE)		
	Left inboard	C4161-3 806 (PK/LB)	C4161-4 807 (PK/LG)		
	Right inboard	C4162-1 802 (OG/RD)	C4162-2 803 (BN/PK)		
	Right outboard	C4162-3 825 (TN/LG)	C4162-4 827 (TN/WH)		
	<ul style="list-style-type: none"> <li>Is a fluctuating AC voltage present?</li> </ul>				
<b>D10</b>	<b>CHECK THE AUDIO CIRCUITS TO THE SUSPECT SUBWOOFER FOR A SHORT TO VOLTAGE</b>				
	<ul style="list-style-type: none"> <li>Ignition OFF.</li> <li>Disconnect: Suspect Subwoofer Amplifier C4157b, C4158b, C4159b, or C4160b.</li> <li>Ignition ON.</li> <li>Measure the voltage between the suspect rear subwoofer, harness side and ground as follows:</li> </ul>				

(Continued)

**DIAGNOSIS AND TESTING (Continued)**

**PINPOINT TEST D: THE SUBWOOFER IS INOPERATIVE/DOES NOT OPERATE CORRECTLY — REAR SUBWOOFER (Continued)**

Test Step			Result / Action to Take		
<b>D10</b>	<b>CHECK THE AUDIO CIRCUITS TO THE SUSPECT SUBWOOFER FOR A SHORT TO VOLTAGE (Continued)</b>		<p><b>Yes</b> REPAIR the circuit in question. TEST the system for normal operation.</p> <p><b>No</b> GO to <b>D11</b>.</p>		
	<b>Suspect Subwoofer</b>	<b>Subwoofer Connector-Pin</b>		<b>Circuit</b>	
	Left outboard	C4161-1		800 (GY/LB)	
		C4161-2		801 (TN/YE)	
	Left inboard	C4161-3		806 (PK/LB)	
		C4161-4		807 (PK/LG)	
	Right inboard	C4162-1		802 (OG/RD)	
		C4162-2		803 (BN/PK)	
	Right outboard	C4162-3		825 (TN/LG)	
		C4162-4		827 (TN/WH)	
	<ul style="list-style-type: none"> <li>Is any voltage present?</li> </ul>				
<b>D11</b>	<b>CHECK THE AUDIO CIRCUITS TO THE SUSPECT SUBWOOFER FOR AN OPEN OR SHORT TO GROUND</b>		<p><b>Yes</b> INSTALL a new rear subwoofer amplifier for the suspect amplifier. REFER to Subwoofer Amplifier — Luggage Compartment in this section. TEST the system for normal operation.</p> <p><b>No</b> REPAIR the circuit in question. TEST the system for normal operation.</p>		
	<ul style="list-style-type: none"> <li>Ignition OFF.</li> <li>Measure the resistance between the suspect rear subwoofer, harness side and the rear amplifier, harness side; and between the suspect rear subwoofer, harness side and ground as follows:</li> </ul>				
	<b>Suspect Subwoofer</b>	<b>Subwoofer Connector-Pin</b>		<b>Rear Amplifier Connector-Pin</b>	<b>Circuit</b>
	Left outboard	C4161-1		C4157b-4	800 (GY/LB)
		C4161-2		C4157b-3	801 (TN/YE)
	Left inboard	C4161-3		C4158b-4	806 (PK/LB)
		C4161-4		C4158b-3	807 (PK/LG)
	Right inboard	C4162-1		C4160b-4	802 (OG/RD)
		C4162-2		C4160b-3	803 (BN/PK)
	Right outboard	C4162-3		C4159b-4	825 (TN/LG)
		C4162-4	C4159b-3	827 (TN/WH)	
	<ul style="list-style-type: none"> <li>Is the resistance less than 5 ohms between the suspect rear subwoofer and the rear subwoofer amplifier, and greater than 10,000 ohms between the suspect rear subwoofer and ground?</li> </ul>				
<b>D12</b>	<b>CHECK FOR CORRECT ACM OPERATION</b>		<p><b>Yes</b> INSTALL a new ACM. REFER to Audio Control Module (ACM) in this section. TEST the system for normal operation.</p> <p><b>No</b> The system is operating correctly at this time. The concern may have been caused by a loose or corroded connector.</p>		
	<ul style="list-style-type: none"> <li>Disconnect the ACM connectors.</li> <li>Check for:                             <ul style="list-style-type: none"> <li>corrosion</li> <li>damaged pins</li> <li>pushed-out pins</li> </ul> </li> <li>Connect the ACM connectors and make sure they seat correctly.</li> <li>Operate the system and determine if the concern is still present.</li> <li>Is the concern still present?</li> </ul>				

**DIAGNOSIS AND TESTING (Continued)**

**Pinpoint Test E: Loud Popping Sound When Cycling The Ignition Switch**

Refer to [Wiring Diagrams Cell 130, Audio System/Navigation](#) for schematic and connector information.

**Normal Operation**

Voltage is supplied to the audio control module (ACM) through circuit 1000 (RD/BK) when the ignition switch is turned to the START position. When the ACM receives this voltage, it mutes all speaker outputs and subwoofer amplifier enable circuits to eliminate the possibility of speaker pops during engine cranking.

This pinpoint test is intended to diagnose the following:

- Fuse
- Wiring, terminals or connectors
- Subwoofer amplifier
- ACM

**PINPOINT TEST E: LOUD POPPING SOUND WHEN CYCLING THE IGNITION SWITCH**

**NOTICE:** Use the correct probe adapter(s) when making measurements. Failure to use the correct probe adapter(s) may damage the connector.

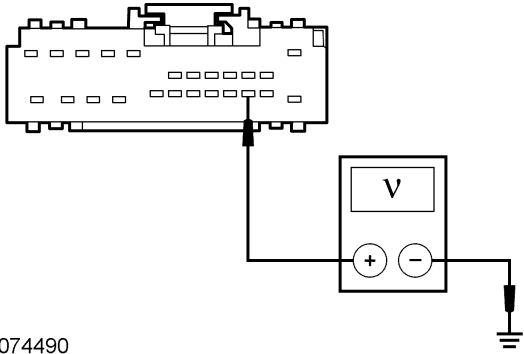
Test Step		Result / Action to Take
<b>E1</b>	<p><b>CHECK CIRCUIT 1000 (RD/BK) FOR VOLTAGE</b></p> <ul style="list-style-type: none"> <li>• Ignition OFF.</li> <li>• Disconnect: ACM <a href="#">C290d</a>.</li> <li>• Disconnect: Starter Relay.</li> <li>• Hold the key in the START position.</li> <li>• Measure the voltage between the ACM <a href="#">C290d-15</a> circuit 1000 (RD/BK), harness side and ground.</li> </ul>  <p>A0074490</p> <ul style="list-style-type: none"> <li>• <b>Is the voltage greater than 10 volts?</b></li> </ul>	<p><b>Yes</b> GO to <a href="#">E2</a>.</p> <p><b>No</b> VERIFY the smart junction box (SJB) fuse 20 (10A) is OK. If OK, REPAIR the circuit. TEST the system for normal operation.</p>
<b>E2</b>	<p><b>ISOLATE THE FRONT/REAR SUBWOOFERS</b></p> <p><b>NOTE:</b> Repeat this step for each subwoofer amplifier.</p> <ul style="list-style-type: none"> <li>• Ignition OFF.</li> <li>• Connect: ACM <a href="#">C290d</a>.</li> <li>• Disconnect: Suspect Subwoofer Amplifier.</li> <li>• Cycle the key through all of the ignition switch positions.</li> <li>• <b>Is a loud popping sound present for only one subwoofer amplifier?</b></li> </ul>	<p><b>Yes</b> INSTALL a new subwoofer amplifier for the suspect subwoofer amplifier. REFER to Subwoofer Amplifier — Door or Subwoofer Amplifier — Luggage Compartment in this section. TEST the system for normal operation.</p> <p><b>No</b> GO to <a href="#">E3</a>.</p>
<b>E3</b>	<p><b>CHECK FOR CORRECT ACM OPERATION</b></p> <ul style="list-style-type: none"> <li>• Connect: Starter Relay.</li> <li>• Disconnect the ACM connectors.</li> <li>• Check for:                         <ul style="list-style-type: none"> <li>— corrosion</li> <li>— damaged pins</li> <li>— pushed-out pins</li> </ul> </li> <li>• Connect the ACM connectors and make sure they seat correctly.</li> <li>• Operate the system and determine if the concern is still present.</li> <li>• <b>Is the concern still present?</b></li> </ul>	<p><b>Yes</b> INSTALL a new ACM. REFER to Audio Control Module (ACM) in this section. TEST the system for normal operation.</p> <p><b>No</b> The system is operating correctly at this time. The concern may have been caused by a loose or corroded connector.</p>

**DIAGNOSIS AND TESTING (Continued)**

**Pinpoint Test F: The Satellite Audio Is Inoperative/Does Not Operate Correctly**

Refer to [Wiring Diagrams Cell 130, Audio System/Navigation for schematic and connector information.](#)

**Normal Operation**

The satellite digital audio receiver system (SDARS) module receives voltage through circuit 729 (RD/WH), and ground through circuit 1204 (BK/OG). Digital signals are received by the satellite antenna and sent to the SDARS module, which then provides audio signals to the audio control module (ACM). The SDARS module and the ACM communicate using the medium speed controller area network (MS-CAN) through circuits 1847 (WH/OG) and 1848 (PK/OG).

It is important to note that a concern in the satellite radio antenna may cause the satellite audio to be inoperative. However, if there is a concern with the satellite radio antenna, DTCs B1031 or B1032 should set. Make sure to verify the integrity of the satellite radio antenna and cable before carrying out this pinpoint test.

- DTC U0184 (Lost Communication With Radio [ACM]) — sets when the SDARS module is missing messages from the ACM for greater than 5 seconds. This results in loss of satellite radio functionality.
- DTC U0193 (Lost Communication With Digital Audio Control Module [SDARS]) — sets when the ACM is missing messages from the SDARS module for greater than 5 seconds. This results in loss of satellite radio functionality.

**This pinpoint test is intended to diagnose the following:**

- Subscription status
- Wiring, terminals or connectors
- SDARS module
- ACM

**PINPOINT TEST F: THE SATELLITE AUDIO IS INOPERATIVE/DOES NOT OPERATE CORRECTLY**

**NOTICE:** Use the correct probe adapter(s) when making measurements. Failure to use the correct probe adapter(s) may damage the connector.

Test Step		Result / Action to Take
<b>F1</b>	<b>VERIFY AN ACTIVE SUBSCRIPTION</b>	<p><b>Yes</b> The subscription has expired. INFORM the customer to contact Sirius to re-activate the subscription.</p> <p><b>No</b> GO to <b>F2</b>.</p>
	<ul style="list-style-type: none"> <li>• Operate the audio system in satellite audio mode and observe the display.</li> <li>• <b>Does the display read CALL SIRIUS?</b></li> </ul>	
<b>F2</b>	<b>CHECK FOR SATELLITE RADIO RECEIVER DTCs</b>	<p><b>Yes</b> If DTC B1031 or DTC B1032 is present, <b>GO to Pinpoint Test G.</b> For DTC U0184 or U0193, <b>GO to F3.</b> For all other DTCs, REFER to the Satellite Digital Audio Receiver System (SDARS) Module DTC Chart in this section.</p> <p><b>No</b> GO to <b>F3</b>.</p>
	<ul style="list-style-type: none"> <li>• Clear the SDARS module DTCs.</li> <li>• Ignition ON.</li> <li>• Ignition OFF.</li> <li>• Wait 10 seconds.</li> <li>• Carry out the SDARS module self-test.</li> <li>• <b>Are any satellite audio system DTCs present?</b></li> </ul>	
<b>F3</b>	<b>CHECK SATELLITE RADIO RECEIVER OPERATION</b>	<p><b>Yes</b> GO to <b>F6</b>.</p> <p><b>No</b> GO to <b>F4</b>.</p>
	<ul style="list-style-type: none"> <li>• Perform the satellite bezel diagnostic self-test.</li> <li>• <b>Are alternating LH/RH tones audible?</b></li> </ul>	

(Continued)

**DIAGNOSIS AND TESTING (Continued)**

**PINPOINT TEST F: THE SATELLITE AUDIO IS INOPERATIVE/DOES NOT OPERATE CORRECTLY (Continued)**

Test Step		Result / Action to Take															
<b>F4</b>	<p><b>CHECK THE AUDIO CIRCUITS FROM THE SATELLITE RADIO RECEIVER FOR A SHORT TO VOLTAGE</b></p> <ul style="list-style-type: none"> <li>Ignition OFF.</li> <li>Disconnect: ACM C290a.</li> <li>Disconnect: SDARS Module C4344.</li> <li>Ignition ON.</li> <li>Measure the voltage between the SDARS module, harness side and ground as follows:</li> </ul> <table border="1"> <thead> <tr> <th>SDARS Module Connector-Pin</th> <th>Circuit</th> </tr> </thead> <tbody> <tr> <td>C4344-5</td> <td>1595 (RD)</td> </tr> <tr> <td>C4344-6</td> <td>1597 (OG)</td> </tr> <tr> <td>C4344-11</td> <td>1594 (WH)</td> </tr> <tr> <td>C4344-12</td> <td>1596 (PK)</td> </tr> </tbody> </table> <ul style="list-style-type: none"> <li>Is any voltage present?</li> </ul>	SDARS Module Connector-Pin	Circuit	C4344-5	1595 (RD)	C4344-6	1597 (OG)	C4344-11	1594 (WH)	C4344-12	1596 (PK)	<p><b>Yes</b> REPAIR the circuit in question. TEST the system for normal operation.</p> <p><b>No</b> GO to F5.</p>					
SDARS Module Connector-Pin	Circuit																
C4344-5	1595 (RD)																
C4344-6	1597 (OG)																
C4344-11	1594 (WH)																
C4344-12	1596 (PK)																
<b>F5</b>	<p><b>CHECK THE AUDIO CIRCUITS FROM THE SATELLITE RADIO RECEIVER FOR AN OPEN OR SHORT TO GROUND</b></p> <ul style="list-style-type: none"> <li>Ignition OFF.</li> <li>Measure the resistance between the SDARS module, harness side and the ACM, harness side; and between the SDARS module, harness side and ground as follows:</li> </ul> <table border="1"> <thead> <tr> <th>SDARS Module Connector-Pin</th> <th>ACM Connector-Pin</th> <th>Circuit</th> </tr> </thead> <tbody> <tr> <td>C4344-5</td> <td>C290a-1</td> <td>1595 (RD)</td> </tr> <tr> <td>C4344-6</td> <td>C290a-9</td> <td>1597 (OG)</td> </tr> <tr> <td>C4344-11</td> <td>C290a-2</td> <td>1594 (WH)</td> </tr> <tr> <td>C4344-12</td> <td>C290a-10</td> <td>1596 (PK)</td> </tr> </tbody> </table> <ul style="list-style-type: none"> <li>Is the resistance less than 5 ohms between the SDARS module and the ACM, and greater than 10,000 ohms between the SDARS module and ground?</li> </ul>	SDARS Module Connector-Pin	ACM Connector-Pin	Circuit	C4344-5	C290a-1	1595 (RD)	C4344-6	C290a-9	1597 (OG)	C4344-11	C290a-2	1594 (WH)	C4344-12	C290a-10	1596 (PK)	<p><b>Yes</b> GO to F6.</p> <p><b>No</b> REPAIR the circuit in question. TEST the system for normal operation.</p>
SDARS Module Connector-Pin	ACM Connector-Pin	Circuit															
C4344-5	C290a-1	1595 (RD)															
C4344-6	C290a-9	1597 (OG)															
C4344-11	C290a-2	1594 (WH)															
C4344-12	C290a-10	1596 (PK)															
<b>F6</b>	<p><b>ISOLATE THE SATELLITE RADIO RECEIVER</b></p> <ul style="list-style-type: none"> <li>Ignition OFF.</li> <li>Substitute a known good SDARS module.</li> <li>Ignition ON.</li> <li>Operate the audio system in satellite audio mode.</li> <li>Does the system operate correctly?</li> </ul>	<p><b>Yes</b> INSTALL a new SDARS module. REFER to Satellite Digital Audio Receiver System (SDARS) Module in this section. TEST the system for normal operation.</p> <p><b>No</b> INSTALL the original SDARS module. INSTALL a new ACM. REFER to Audio Control Module (ACM) in this section. TEST the system for normal operation.</p>															

**DIAGNOSIS AND TESTING (Continued)**

**Pinpoint Test G: Poor Reception — Satellite Audio**

**Normal Operation**

Digital signals are received by the satellite antenna and sent to the satellite digital audio receiver system (SDARS) module, which then converts the signals and provides audio signals to the audio control module (ACM).

- DTC B1031 (SDARS Satellite Antenna Open) — sets when an open or high resistance is detected in the satellite antenna circuit. This DTC can be either continuous or on-demand.

- DTC B1032 (SDARS Satellite Antenna Short) — sets when a short to ground is detected in the satellite antenna circuit. This DTC can be either continuous or on-demand.

**This pinpoint test is intended to diagnose the following:**

- Obstructions to the line of sight
- Satellite radio antenna cable
- Satellite radio antenna
- SDARS module

**PINPOINT TEST G: POOR RECEPTION — SATELLITE AUDIO**

**NOTICE:** Use the correct probe adapter(s) when making measurements. Failure to use the correct probe adapter(s) may damage the connector.

Test Step		Result / Action to Take
<b>G1</b>	<b>REVIEW THE DTCs</b>	<b>Yes</b> GO to <b>G3</b> . <b>No</b> GO to <b>G2</b> .
	<ul style="list-style-type: none"> <li>• Review the DTCs from the SDARS module self-test.</li> <li>• <b>Is DTC B1031 or B1032 present?</b></li> </ul>	
<b>G2</b>	<b>CHECK THE OPERATION OF THE SATELLITE AUDIO</b>	<b>Yes</b> The system is OK at this time. ADVISE the customer of the condition. <b>No</b> GO to <b>G3</b> .
	<ul style="list-style-type: none"> <li>• Drive the vehicle to an open location, free of obstacles.</li> <li>• Operate the audio system in satellite audio mode.</li> <li>• <b>Is the reception OK?</b></li> </ul>	
<b>G3</b>	<b>CHECK THE SATELLITE ANTENNA CABLE</b>	<b>Yes</b> GO to <b>G4</b> . <b>No</b> INSTALL a new satellite radio antenna cable. CLEAR the DTCs. REPEAT the self-test.
	<ul style="list-style-type: none"> <li>• Ignition OFF.</li> <li>• Disconnect: Satellite Antenna Connection (at SDARS Module).</li> <li>• Disconnect: Satellite Antenna Connection (at satellite antenna).</li> <li>• Measure the resistance of the satellite radio antenna cable between the SDARS module and the satellite antenna connection.</li> <li>• <b>Is the resistance less than 1 ohm?</b></li> </ul>	
<b>G4</b>	<b>SUBSTITUTE THE SATELLITE ANTENNA</b>	<b>Yes</b> INSTALL a new satellite radio antenna. REFER to Antenna — Satellite Radio in this section. CLEAR the DTCs. REPEAT the self-test. <b>No</b> INSTALL a new SDARS module. REFER to Satellite Digital Audio Receiver System (SDARS) Module in this section. TEST the system for normal operation after the repair.
	<ul style="list-style-type: none"> <li>• Install a known good satellite antenna.</li> <li>• Operate the audio system in satellite audio mode.</li> <li>• <b>Is the reception OK?</b></li> </ul>	

**DIAGNOSIS AND TESTING (Continued)**

**Pinpoint Test H: No Global Positioning System (GPS) Antenna Signal**

This pinpoint test is intended to diagnose the following:

**Normal Operation**

The GPS antenna provides information from the GPS satellite system to the GPS receiver in the navigation module. This information is used to calculate vehicle position and direction of travel.

- GPS antenna
- ACM

- DTC B2204 (GPS Antenna Connection Open or Short) — sets when an open, short to ground, or short to voltage is detected in the GPS antenna circuit. This DTC can be either continuous or on-demand.

**PINPOINT TEST H: NO GLOBAL POSITIONING SYSTEM (GPS) ANTENNA SIGNAL**

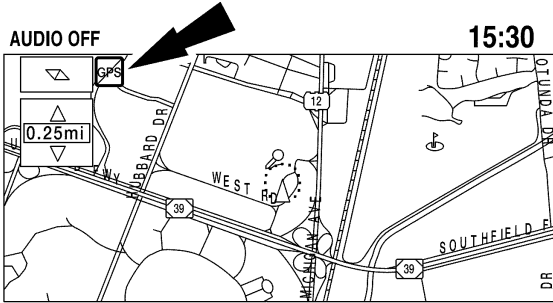
Test Step		Result / Action to Take
<b>H1</b>	<p><b>CHECK THE OPERATION OF THE GPS ICON</b></p> <ul style="list-style-type: none"> <li>• Move the vehicle outside of any enclosed structure to an area that is unobstructed by trees, tall buildings, and bridges.</li> <li>• Operate the audio system in navigation mode.</li> </ul>  <p>N0026638</p> <ul style="list-style-type: none"> <li>• <b>Does the GPS icon appear, then disappear?</b></li> </ul>	<p><b>Yes</b> The system is operating correctly at this time. NOTIFY the customer that obstructions to the line of sight may affect the GPS antenna.</p> <p><b>No</b> GO to <b>H2</b>.</p>
<b>H2</b>	<p><b>CHECK THE ACM RECORDED DTCs</b></p> <ul style="list-style-type: none"> <li>• Check the recorded DTCs from the ACM self-test.</li> <li>• <b>Is DTC B2204 recorded?</b></li> </ul>	<p><b>Yes</b> GO to <b>H4</b>.</p> <p><b>No</b> GO to <b>H3</b>.</p>
<b>H3</b>	<p><b>CHECK THE GPS ANTENNA MOUNTING</b></p> <ul style="list-style-type: none"> <li>• Verify the GPS antenna is installed properly and no aftermarket equipment is obstructing it.</li> <li>• <b>Is the GPS antenna mounted properly?</b></li> </ul>	<p><b>Yes</b> GO to <b>H4</b>.</p> <p><b>No</b> Correctly <b>INSTALL</b> the GPS antenna. REFER to Global Positioning System (GPS) Antenna in this section. TEST the system for normal operation.</p>
<b>H4</b>	<p><b>SUBSTITUTE THE GPS ANTENNA</b></p> <ul style="list-style-type: none"> <li>• Install a good known GPS antenna. Refer to Global Positioning System (GPS) Antenna in this section.</li> <li>• Move the vehicle outside of any enclosed structure to an area that is unobstructed by trees, tall buildings, and bridges.</li> </ul>	

(Continued)

**DIAGNOSIS AND TESTING (Continued)**

**PINPOINT TEST H: NO GLOBAL POSITIONING SYSTEM (GPS) ANTENNA SIGNAL (Continued)**

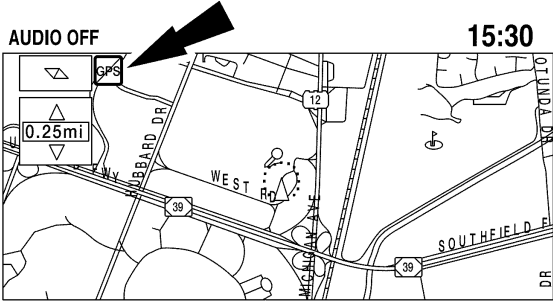
Test Step		Result / Action to Take
<b>H4</b>	<p><b>SUBSTITUTE THE GPS ANTENNA (Continued)</b></p> <ul style="list-style-type: none"> <li>Operate the audio system in navigation mode.</li> </ul>  <p>N0026638</p> <ul style="list-style-type: none"> <li><b>Does the GPS icon appear, then disappear?</b></li> </ul>	<p><b>Yes</b>                      INSTALL a new GPS antenna. REFER to Global Positioning System (GPS) Antenna in this section. CLEAR the DTCs. REPEAT the self-test.</p> <p><b>No</b>                      INSTALL the original GPS antenna. GO to <b>H5</b>.</p>
<b>H5</b>	<p><b>CHECK FOR CORRECT ACM OPERATION</b></p> <ul style="list-style-type: none"> <li>Disconnect all the ACM connectors.</li> <li>Check for:                             <ul style="list-style-type: none"> <li>corrosion</li> <li>damaged pins</li> <li>pushed-out pins</li> </ul> </li> <li>Connect all the ACM connectors and make sure they seat correctly.</li> <li>Operate the system and verify the concern is still present.</li> <li><b>Is the concern still present?</b></li> </ul>	<p><b>Yes</b>                      INSTALL a new ACM. REFER to Audio Control Module (ACM) in this section. TEST the system for normal operation.</p> <p><b>No</b>                      The system is operating correctly at this time. The concern may have been caused by a loose or corroded connector. CLEAR the DTCs. REPEAT the self-test.</p>

**Pinpoint Test I: The Audible Switch Feedback Is Inoperative**

**Normal Operation**

The audible switch feedback settings are controlled by the audio control module (ACM). The audible switch feedback can be set to ALL, TOUCH SCREEN, or NONE, depending on user preference.

**This pinpoint test is intended to diagnose the following:**

- Audible switch feedback setting
- ACM

**PINPOINT TEST I: THE AUDIBLE SWITCH FEEDBACK IS INOPERATIVE**

Test Step		Result / Action to Take
<b>I1</b>	<p><b>CHECK THE SWITCH DISPLAY</b></p> <ul style="list-style-type: none"> <li>Ignition ON.</li> <li>Turn the ACM on.</li> <li>Press the MENU button.</li> </ul>	

(Continued)

**DIAGNOSIS AND TESTING (Continued)**

**PINPOINT TEST I: THE AUDIBLE SWITCH FEEDBACK IS INOPERATIVE (Continued)**

Test Step		Result / Action to Take																														
<b>I1</b>	<p><b>CHECK THE SWITCH DISPLAY (Continued)</b></p> <ul style="list-style-type: none"> <li>Select the FEEDBACK tab.</li> </ul> <div style="border: 1px solid black; padding: 5px; margin: 10px 0;"> <p style="text-align: center;">AUDIO OFF <span style="float: right;">15:32</span></p> <table border="1" style="width: 100%; border-collapse: collapse;"> <tr> <td style="width: 15%;">DISPLAY</td> <td style="width: 15%;">DATE/TIME</td> <td style="width: 15%;">FEED-BACK</td> <td style="width: 15%;">SECURITY</td> <td style="width: 15%;">HELP</td> <td style="width: 15%;">SYSTEM INFO</td> </tr> <tr> <td colspan="2">FEEDBACK</td> <td>ALL BUTTONS</td> <td>TOUCH SCREEN</td> <td colspan="2">NONE</td> </tr> <tr> <td colspan="2">LANGUAGE</td> <td>ENGLISH</td> <td>ESPAÑOL</td> <td colspan="2">FRANÇAIS</td> </tr> <tr> <td>VOICE VOLUME</td> <td>◀ 16 ▶</td> <td colspan="2">TEST</td> <td colspan="2"></td> </tr> <tr> <td>NAVIGATION GUIDANCE</td> <td>OFF</td> <td>ON</td> <td colspan="3">DEFAULT SETTING</td> </tr> </table> </div> <p>N0026637</p> <ul style="list-style-type: none"> <li>Is <b>NONE</b> highlighted on the audible feedback settings?</li> </ul>	DISPLAY	DATE/TIME	FEED-BACK	SECURITY	HELP	SYSTEM INFO	FEEDBACK		ALL BUTTONS	TOUCH SCREEN	NONE		LANGUAGE		ENGLISH	ESPAÑOL	FRANÇAIS		VOICE VOLUME	◀ 16 ▶	TEST				NAVIGATION GUIDANCE	OFF	ON	DEFAULT SETTING			<p><b>Yes</b> SELECT ALL BUTTONS. TEST the system for normal operation.</p> <p><b>No</b> GO to <b>I2</b>.</p>
DISPLAY	DATE/TIME	FEED-BACK	SECURITY	HELP	SYSTEM INFO																											
FEEDBACK		ALL BUTTONS	TOUCH SCREEN	NONE																												
LANGUAGE		ENGLISH	ESPAÑOL	FRANÇAIS																												
VOICE VOLUME	◀ 16 ▶	TEST																														
NAVIGATION GUIDANCE	OFF	ON	DEFAULT SETTING																													
<b>I2</b>	<p><b>CHECK FOR CORRECT ACM OPERATION</b></p> <ul style="list-style-type: none"> <li>Disconnect all the ACM connectors.</li> <li>Check for:                             <ul style="list-style-type: none"> <li>— corrosion</li> <li>— damaged pins</li> <li>— pushed-out pins</li> </ul> </li> <li>Connect all the ACM connectors and make sure they seat correctly.</li> <li>Operate the system and verify the concern is still present.</li> <li>Is the concern still present?</li> </ul>	<p><b>Yes</b> INSTALL a new ACM. REFER to Audio Control Module (ACM) in this section. TEST the system for normal operation.</p> <p><b>No</b> The system is operating correctly at this time. The concern may have been caused by a loose or corroded connector. CLEAR the DTCs. REPEAT the self-test.</p>																														

**Pinpoint Test J: The Voice Guidance Is Inoperative/Does Not Operate Correctly**

**Normal Operation**

The voice guidance settings are controlled by the audio control module (ACM). The voice guidance volume can be adjusted or turned off depending on user preference.

**This pinpoint test is intended to diagnose the following:**

- Incorrect system setting
- ACM

**PINPOINT TEST J: THE VOICE GUIDANCE IS INOPERATIVE/DOES NOT OPERATE CORRECTLY**

Test Step		Result / Action to Take
<b>J1</b>	<p><b>CHECK THE VOICE GUIDANCE SETTINGS</b></p> <ul style="list-style-type: none"> <li>Ignition ON.</li> <li>Turn the ACM on.</li> <li>Press the MENU button.</li> </ul>	

(Continued)

**DIAGNOSIS AND TESTING (Continued)**

**PINPOINT TEST J: THE VOICE GUIDANCE IS INOPERATIVE/DOES NOT OPERATE CORRECTLY (Continued)**

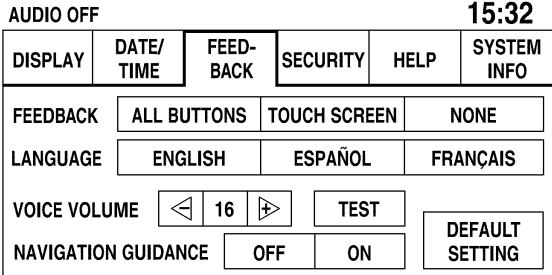
Test Step		Result / Action to Take
<b>J1</b>	<p><b>CHECK THE VOICE GUIDANCE SETTINGS (Continued)</b></p> <ul style="list-style-type: none"> <li>Select the FEEDBACK tab.</li> </ul>  <p>N0026637</p> <ul style="list-style-type: none"> <li>Select DEFAULT SETTING.</li> <li>Verify the voice guidance operation.</li> <li><b>Does the voice guidance operate correctly?</b></li> </ul>	<p><b>Yes</b> The system is operating correctly at this time.</p> <p><b>No</b> GO to <b>J2</b>.</p>
<b>J2</b>	<p><b>CHECK FOR CORRECT ACM OPERATION</b></p> <ul style="list-style-type: none"> <li>Disconnect all the ACM connectors.</li> <li>Check for:                         <ul style="list-style-type: none"> <li>— corrosion</li> <li>— damaged pins</li> <li>— pushed-out pins</li> </ul> </li> <li>Connect all the ACM connectors and make sure they seat correctly.</li> <li>Operate the system and verify the concern is still present.</li> <li><b>Is the concern still present?</b></li> </ul>	<p><b>Yes</b> INSTALL a new ACM. REFER to Audio Control Module (ACM) in this section. TEST the system for normal operation.</p> <p><b>No</b> The system is operating correctly at this time. The concern may have been caused by a loose or corroded connector. CLEAR the DTCs. REPEAT the self-test.</p>

**Pinpoint Test K: DTC B2924 — Audio Button Stuck**

**Normal Operation**

This DTC sets as a continuous DTC when an audio control module (ACM) button is detected as active for greater than 120 seconds, or sets on-demand if a button is detected as active for greater than 3 seconds during the self-test.

**This pinpoint test is intended to diagnose the following:**

- ACM

**PINPOINT TEST K: DTC B2924 — AUDIO BUTTON STUCK**

Test Step		Result / Action to Take
<b>K1</b>	<p><b>CHECK FOR STUCK ACM BUTTONS</b></p> <ul style="list-style-type: none"> <li>Operate the audio system in radio tuner mode.</li> <li>Enter the self-diagnostic menu and select the HARDKEY TEST function.</li> </ul>	

(Continued)

**DIAGNOSIS AND TESTING (Continued)**

**PINPOINT TEST K: DTC B2924 — AUDIO BUTTON STUCK (Continued)**

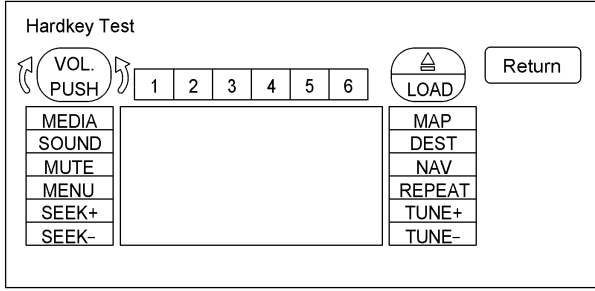
Test Step	Result / Action to Take
<p><b>K1</b> <b>CHECK FOR STUCK ACM BUTTONS (Continued)</b></p> <ul style="list-style-type: none"> <li><b>NOTE:</b> If any button is pushed, the corresponding button on the screen appears highlighted. Observe the buttons on the screen.</li> </ul> <p>Bezel Diagnostics</p>  <p>N0027403</p> <ul style="list-style-type: none"> <li><b>Does the hardkey test indicate a stuck button?</b></li> </ul>	<p><b>Yes</b> GO to <b>K2</b>.</p> <p><b>No</b> The system is operating correctly at this time.</p>
<p><b>K2</b> <b>CHECK FOR CORRECT ACM OPERATION</b></p> <ul style="list-style-type: none"> <li>Disconnect all the ACM connectors.</li> <li>Check for: <ul style="list-style-type: none"> <li>— corrosion</li> <li>— damaged pins</li> <li>— pushed-out pins</li> </ul> </li> <li>Connect all the ACM connectors and make sure they seat correctly.</li> <li>Operate the system and verify the concern is still present.</li> <li><b>Is the concern still present?</b></li> </ul>	<p><b>Yes</b> INSTALL a new ACM. REFER to Audio Control Module (ACM) in this section. TEST the system for normal operation.</p> <p><b>No</b> The system is operating correctly at this time. The concern may have been caused by a loose or corroded connector. CLEAR the DTCs. REPEAT the self-test.</p>

**Pinpoint Test L: The Position Cursor Is Inaccurate**

**Normal Operation**

The primary source of vehicle location for the navigation system is the audio control module (ACM) receiving the position signal through the global positioning system (GPS) antenna.

In addition, the ACM receives the wheel pulse signal from the instrument cluster (which gateways the signal from the ABS module). This secondary signal is used to calculate vehicle position when the GPS signal is lost. It also supports the adaptive learning function of the ACM, whereby the ACM can compensate for long-term differences between the GPS signal location, and the actual distance traveled by the vehicle.

- DTC B2204 (GPS Antenna Connection Open or Short) — sets when an open, short to ground, or short to voltage is detected in the GPS antenna circuit. If DTC B2204 is present, [GO to Pinpoint Test H](#).

- DTC U0155 (Lost Communication With Instrument Panel Cluster [IC] Control Module) — sets when the wheel pulse signal is lost for greater than 5 seconds. When the signal is lost, DTC U2473 should also be set. If no symptoms are present and DTC U2473 is not present, this DTC can be ignored, as it may have been set by a low battery voltage condition.
- DTC U2473 (Unexpected Vehicle Speed) — sets when the calculated vehicle distance traveled based on the wheel pulse signal does not agree with the GPS antenna location. To do this, the ACM compares the wheel pulse signal during a 4-second range, and compares it with the change in GPS antenna location. If the ACM finds that the variation is greater than 0.5% after performing this check 4 times, it sets DTC U2473.

**This pinpoint test is intended to diagnose the following:**

- VSS signal concern
- ACM

**DIAGNOSIS AND TESTING (Continued)**

**PINPOINT TEST L: THE POSITION CURSOR IS INACCURATE**

Test Step		Result / Action to Take
<b>L1</b>	<b>CHECK THE ACM DTCs</b>	<b>Yes</b> GO to <b>L2</b> .  <b>No</b> GO to Pinpoint Test H.
	<ul style="list-style-type: none"> <li>Review the DTCs from the ACM self-test.</li> <li><b>Is DTC U2473 present?</b></li> </ul>	
<b>L2</b>	<b>CHECK THE INSTRUMENT CLUSTER AND ABS MODULE DTCs</b>	<b>Yes</b> REFER to Section 413-01 (instrument cluster) or Section 206-09 (ABS module) to diagnose a fault in the wheel pulse signal.  <b>No</b> GO to <b>L3</b> .
	<ul style="list-style-type: none"> <li>Carry out the self-test for the instrument cluster and the ABS module.</li> <li><b>Are any DTCs recorded?</b></li> </ul>	
<b>L3</b>	<b>CHECK FOR CORRECT ACM OPERATION</b>	<b>Yes</b> INSTALL a new ACM. REFER to Audio Control Module (ACM) in this section. TEST the system for normal operation.  <b>No</b> The system is operating correctly at this time. The concern may have been caused by a loose or corroded connector. CLEAR the DTCs. REPEAT the self-test.
	<ul style="list-style-type: none"> <li>Disconnect all the ACM connectors.</li> <li>Check for:                             <ul style="list-style-type: none"> <li>corrosion</li> <li>damaged pins</li> <li>pushed-out pins</li> </ul> </li> <li>Connect all the ACM connectors and make sure they seat correctly.</li> <li>Operate the system and verify the concern is still present.</li> <li><b>Is the concern still present?</b></li> </ul>	

**Pinpoint Test M: The Speed Sensitive Volume Does Not Operate Correctly**

**Normal Operation**

The speed sensitive volume function adjusts the volume based on the vehicle speed sensor (VSS) signal from the instrument cluster. The instrument cluster does not generate the VSS signal: it gateways the signal from the PCM.

- DTC U0155 (Lost Communication With Instrument Panel Cluster [IC] Control Module) — sets when the VSS signal is lost for greater than 5 seconds. When the signal is lost, the audio control module (ACM) turns the speed sensitive volume feature off. The smart junction box (SJB) also receives this signal, and should demonstrate symptoms if the VSS signal is lost. If no symptoms are present, this DTC can be ignored, as it may have been set by a low battery voltage condition.

**This pinpoint test is intended to diagnose the following:**

- Speed sensitive volume setting
- VSS signal concern
- ACM

**PINPOINT TEST M: THE SPEED SENSITIVE VOLUME DOES NOT OPERATE CORRECTLY**

Test Step		Result / Action to Take
<b>M1</b>	<b>CHECK THE SPEEDOMETER OPERATION</b>	<b>Yes</b> GO to <b>M2</b> .  <b>No</b> REFER to Section 413-01.
	<ul style="list-style-type: none"> <li>Drive the vehicle and observe the speedometer.</li> <li><b>Does the speedometer operate correctly?</b></li> </ul>	
<b>M2</b>	<b>CHECK THE SPEED SENSITIVE VOLUME SETTING</b>	
	<ul style="list-style-type: none"> <li>Turn the speed sensitive volume off. Refer to the Owner's Literature.</li> </ul>	

(Continued)

**DIAGNOSIS AND TESTING (Continued)****PINPOINT TEST M: THE SPEED SENSITIVE VOLUME DOES NOT OPERATE CORRECTLY (Continued)**

Test Step		Result / Action to Take
<b>M2</b>	<b>CHECK THE SPEED SENSITIVE VOLUME SETTING (Continued)</b>	<p><b>Yes</b> The system is operating correctly at this time. INFORM the customer of proper operation.</p> <p><b>No</b> GO to <b>M3</b>.</p>
	<ul style="list-style-type: none"> <li>Operate the audio system in radio tuner mode.</li> <li>Drive the vehicle at various speeds and observe the speaker volume.</li> <li>Set the speed sensitive volume to maximum compensation. Refer to the Owner's Literature.</li> <li>Operate the audio system in radio tuner mode.</li> <li>Drive the vehicle at various speeds and observe the speaker volume.</li> <li><b>Does the volume remain constant with the speed sensitive volume turned off, and increase and decrease with vehicle speed with the speed sensitive volume set to maximum?</b></li> </ul>	
<b>M3</b>	<b>CHECK FOR DTC U0155</b>	<p><b>Yes</b> GO to <b>M5</b>.</p> <p><b>No</b> GO to <b>M4</b>.</p>
	<ul style="list-style-type: none"> <li>Ignition OFF.</li> <li>Clear any ACM DTCs.</li> <li>Ignition ON.</li> <li>Wait 10 seconds, and re-run the ACM self-test.</li> <li>Run the SJB self-test.</li> <li><b>Is DTC U0155 present in both the ACM and the SJB?</b></li> </ul>	
<b>M4</b>	<b>CHECK FOR CORRECT ACM OPERATION</b>	<p><b>Yes</b> INSTALL a new ACM. REFER to Audio Control Module (ACM) in this section. TEST the system for normal operation.</p> <p><b>No</b> The system is operating correctly at this time. The concern may have been caused by a loose or corroded connector. CLEAR the DTCs. REPEAT the self-test.</p>
	<ul style="list-style-type: none"> <li>Disconnect all the ACM connectors.</li> <li>Check for: <ul style="list-style-type: none"> <li>corrosion</li> <li>damaged pins</li> <li>pushed-out pins</li> </ul> </li> <li>Connect all the ACM connectors and make sure they seat correctly.</li> <li>Operate the system and determine if the concern is still present.</li> <li><b>Is the concern still present?</b></li> </ul>	
<b>M5</b>	<b>CHECK FOR CORRECT INSTRUMENT CLUSTER OPERATION</b>	<p><b>Yes</b> INSTALL a new instrument cluster. REFER to Section 413-01. CLEAR the ACM DTCs. TEST the system for normal operation.</p> <p><b>No</b> The system is operating correctly at this time. The concern may have been caused by a loose or corroded connector. CLEAR the DTCs. REPEAT the self-test.</p>
	<ul style="list-style-type: none"> <li>Disconnect the instrument cluster connector.</li> <li>Check for: <ul style="list-style-type: none"> <li>corrosion</li> <li>damaged pins</li> <li>pushed-out pins</li> </ul> </li> <li>Connect the instrument cluster connector and make sure it seats correctly.</li> <li>Operate the system and determine if the concern is still present.</li> <li><b>Is the concern still present?</b></li> </ul>	

**Pinpoint Test N: The Audio Input Jack Is Inoperative/Does Not Operate Correctly**

Refer to [Wiring Diagrams Cell 130, Audio System/Navigation for schematic and connector information](#).

**Normal Operation**

Audio signals are sent from the audio input jack to the audio control module (ACM). There are no external power or ground circuits to the audio input jack.

**This pinpoint test is intended to diagnose the following:**

- Wiring, terminals or connectors
- Audio input jack
- ACM

**DIAGNOSIS AND TESTING (Continued)**

**PINPOINT TEST N: THE AUDIO INPUT JACK IS INOPERATIVE/DOES NOT OPERATE CORRECTLY**

**NOTICE:** Use the correct probe adapter(s) when making measurements. Failure to use the correct probe adapter(s) may damage the connector.

**NOTE:** Before performing this pinpoint test, be sure the MP3 device is operating correctly.

Test Step		Result / Action to Take													
N1	<b>CHECK THE AUDIO INPUT JACK CIRCUITS FOR A SHORT TO VOLTAGE</b>	<p><b>Yes</b> REPAIR the circuit in question. TEST the system for normal operation.</p> <p><b>No</b> GO to <b>N2</b>.</p>													
	<ul style="list-style-type: none"> <li>Ignition OFF.</li> <li>Disconnect: Audio Input Jack <b>C3312</b>.</li> <li>Ignition ON.</li> <li>Measure the voltage between the audio input jack, harness side and ground as follows:</li> </ul> <table border="1"> <thead> <tr> <th>Audio Input Jack Connector-Pin</th> <th>Circuit</th> </tr> </thead> <tbody> <tr> <td><b>C3312-1</b></td> <td>2048 (RD/BK)</td> </tr> <tr> <td><b>C3312-2</b></td> <td>2047 (RD/WH)</td> </tr> <tr> <td><b>C3312-3</b></td> <td>2049 (LG/WH)</td> </tr> <tr> <td><b>C3312-4</b></td> <td>2050 (LG/BK)</td> </tr> </tbody> </table> <ul style="list-style-type: none"> <li>Is any voltage present?</li> </ul>		Audio Input Jack Connector-Pin	Circuit	<b>C3312-1</b>	2048 (RD/BK)	<b>C3312-2</b>	2047 (RD/WH)	<b>C3312-3</b>	2049 (LG/WH)	<b>C3312-4</b>	2050 (LG/BK)			
Audio Input Jack Connector-Pin	Circuit														
<b>C3312-1</b>	2048 (RD/BK)														
<b>C3312-2</b>	2047 (RD/WH)														
<b>C3312-3</b>	2049 (LG/WH)														
<b>C3312-4</b>	2050 (LG/BK)														
N2	<b>CHECK THE AUDIO INPUT JACK CIRCUITS FOR AN OPEN OR SHORT TO GROUND</b>	<p><b>Yes</b> GO to <b>N3</b>.</p> <p><b>No</b> REPAIR the circuit in question. TEST the system for normal operation.</p>													
	<ul style="list-style-type: none"> <li>Ignition OFF.</li> <li>Disconnect: ACM <b>C290a</b>.</li> <li>Measure the resistance between the audio input jack, harness side and the ACM, harness side; and between the audio input jack, harness side and ground as follows:</li> </ul> <table border="1"> <thead> <tr> <th>Audio Input Jack Connector-Pin</th> <th>ACM Connector-Pin</th> <th>Circuit</th> </tr> </thead> <tbody> <tr> <td><b>C3312-1</b></td> <td><b>C290a-6</b></td> <td>2048 (RD/BK)</td> </tr> <tr> <td><b>C3312-2</b></td> <td><b>C290a-14</b></td> <td>2047 (RD/WH)</td> </tr> <tr> <td><b>C3312-3</b></td> <td><b>C290a-8</b></td> <td>2049 (LG/WH)</td> </tr> <tr> <td><b>C3312-4</b></td> <td><b>C290a-7</b></td> <td>2050 (LG/BK)</td> </tr> </tbody> </table> <ul style="list-style-type: none"> <li>Is the resistance less than 5 ohms between the audio input jack and the ACM, and greater than 10,000 ohms between the audio input jack and ground?</li> </ul>		Audio Input Jack Connector-Pin	ACM Connector-Pin	Circuit	<b>C3312-1</b>	<b>C290a-6</b>	2048 (RD/BK)	<b>C3312-2</b>	<b>C290a-14</b>	2047 (RD/WH)	<b>C3312-3</b>	<b>C290a-8</b>	2049 (LG/WH)	<b>C3312-4</b>
Audio Input Jack Connector-Pin	ACM Connector-Pin	Circuit													
<b>C3312-1</b>	<b>C290a-6</b>	2048 (RD/BK)													
<b>C3312-2</b>	<b>C290a-14</b>	2047 (RD/WH)													
<b>C3312-3</b>	<b>C290a-8</b>	2049 (LG/WH)													
<b>C3312-4</b>	<b>C290a-7</b>	2050 (LG/BK)													
N3	<b>SUBSTITUTE THE AUDIO INPUT JACK</b>	<p><b>Yes</b> INSTALL a new audio input jack. TEST the system for normal operation.</p> <p><b>No</b> INSTALL the original audio input jack. INSTALL a new ACM. REFER to Audio Control Module (ACM) in this section. TEST the system for normal operation.</p>													
	<ul style="list-style-type: none"> <li>Install a known good audio input jack.</li> <li>Operate the audio system in auxiliary audio mode.</li> <li>Does the system operate correctly?</li> </ul>														

---

## GENERAL PROCEDURES

### Audio Unit Part Number Retrieval

#### Audio Systems Without Navigation

**NOTE:** The terms “Audio Control Module (ACM)” and “audio unit” refer to the same component.

1. Turn the ACM on.
2. Press and hold preset buttons 3 and 6 for 3 seconds. The speaker walk-around test will begin.
3. Before the speaker walk-around test is complete, press preset button 6.
4. **NOTE:** This step will cause the ACM to auto-scroll through configuration 1, configuration 2, EEPROM number, and ACM part number.

Press the TUNE UP button.

5. **NOTE:** Step 4 may need to be repeated until the ACM part number can be recorded.  
Record the ACM part number.

6. Turn the ACM off.

#### Navigation Audio System

1. Turn the ACM on.
  2. Press and hold preset buttons 3 and 6 for 3 seconds. The speaker walk-around test will begin.
  3. Before the speaker walk-around test is complete, press END TEST on the display screen.
  4. Select SYSTEM INFO from the menu.
  5. Record the ACM part number.
  6. Turn the ACM off.
-

---

## GENERAL PROCEDURES

### Satellite Radio Receiver Electronic Serial Number (ESN) Retrieval

#### Audio Systems Without Navigation

1. Operate the audio system in satellite radio mode.
2. Press and hold the AUX button and preset button 1, simultaneously.
  - The satellite radio receiver Electronic Serial Number (ESN) will be displayed on the screen.
3. Record the satellite radio receiver ESN.

4. Turn the audio system off.

#### Audio Systems With Navigation

1. Turn the audio system on.
  2. Press the MENU button.
  3. Select the SYSTEM INFO tab.
  4. **NOTE:** The satellite radio receiver ESN is shown on the lower left corner of the screen with the text “SR ESN:”.  
Record the satellite radio receiver ESN.
  5. Turn the audio system off.
-

## REMOVAL AND INSTALLATION

### Antenna — Satellite Radio

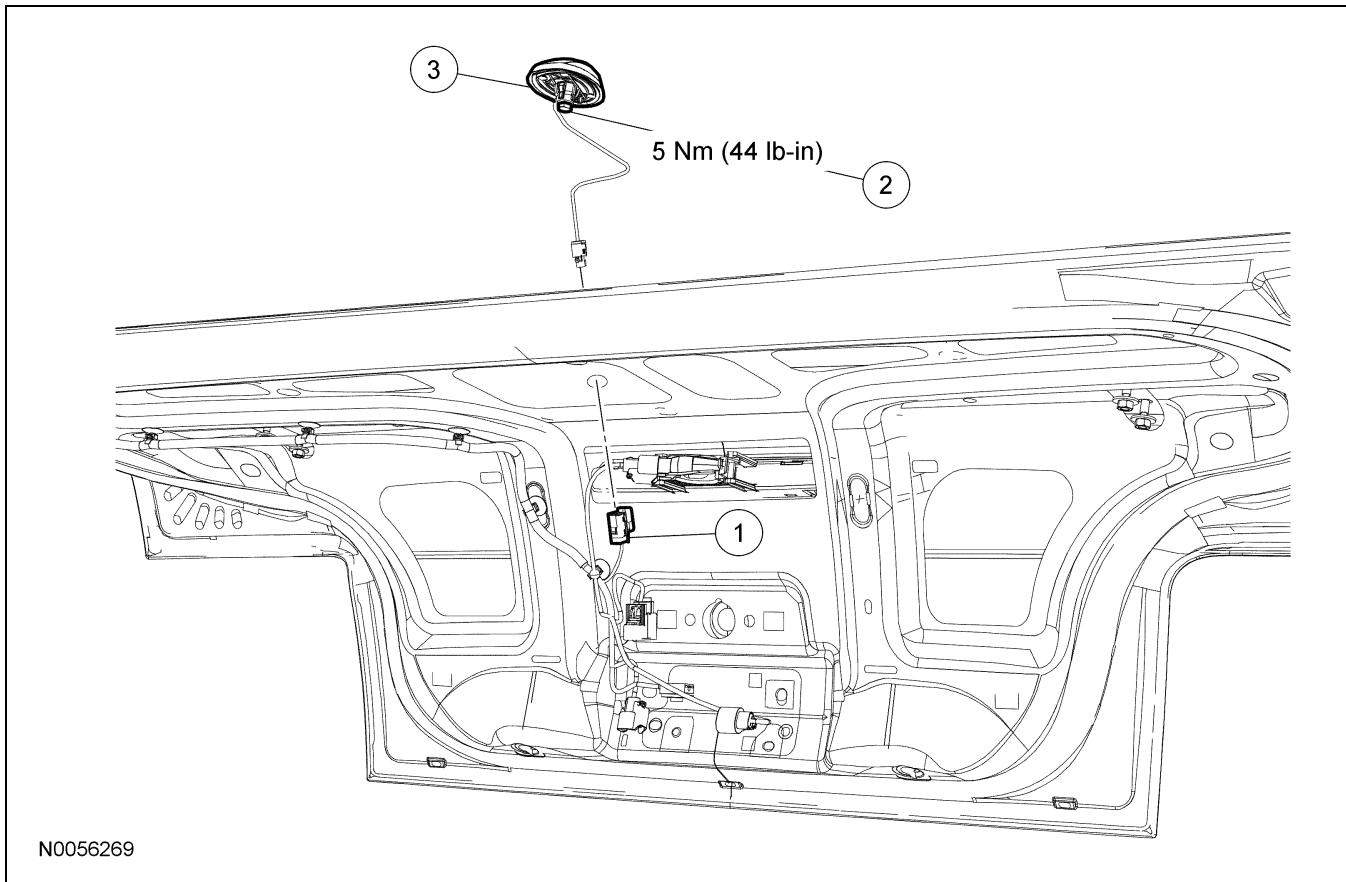

Item	Part Number	Description
1	—	Satellite radio antenna cable electrical connector (part of 19B516)
2	—	Satellite radio antenna bolt (part of 18C964)
3	18C964	Satellite radio antenna

2. Remove the satellite radio antenna.
  - Disconnect the electrical connector.
  - Remove the antenna and wiring through the hole in the luggage compartment lid.
3. To install, reverse the removal procedure.

### Removal and Installation

1. Loosen the satellite radio antenna bolt.
  - To install, tighten to 5 Nm (44 lb-in).

## REMOVAL AND INSTALLATION

### Antenna Base

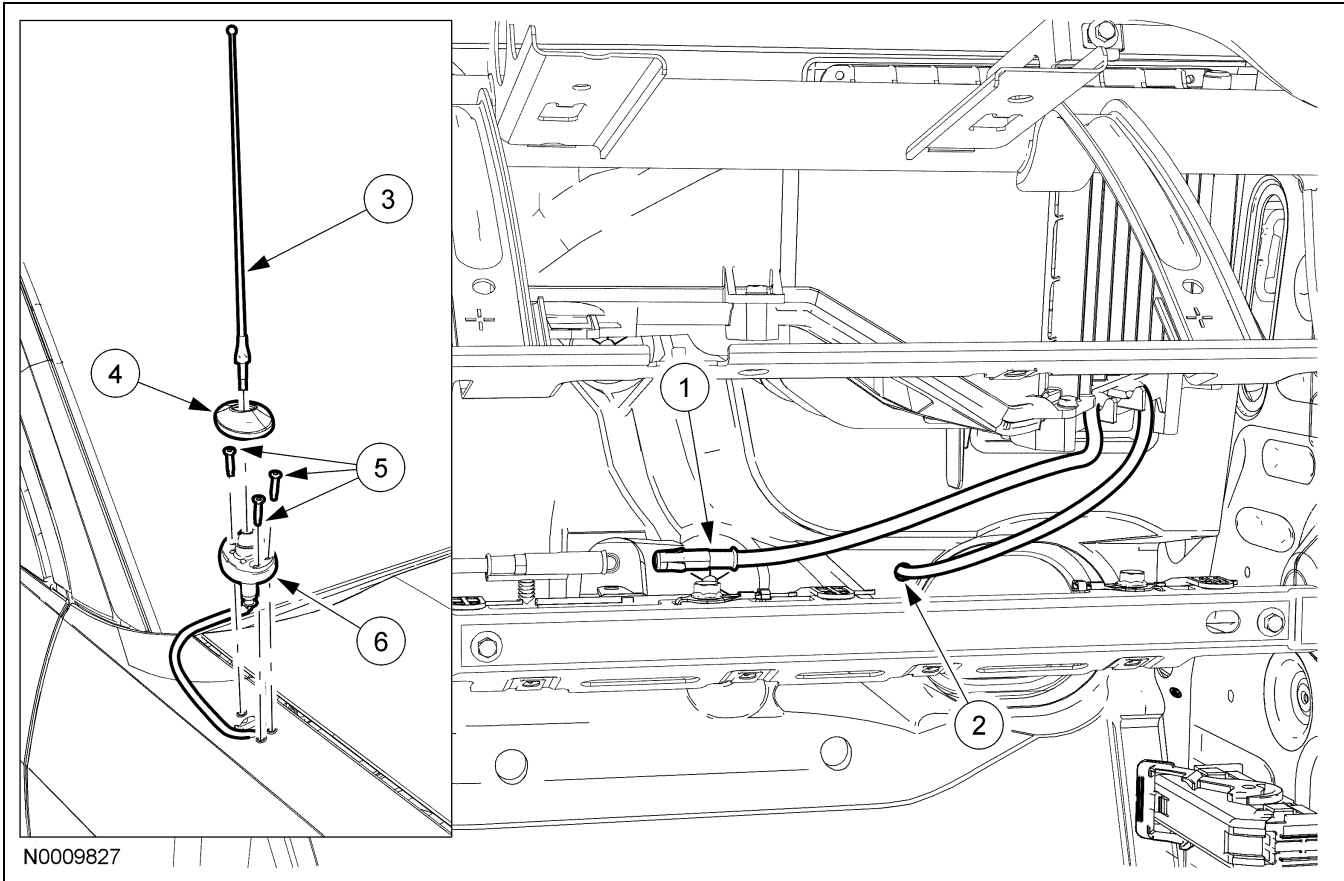

Item	Part Number	Description
1	19A136	Antenna in-line connector
2	18A984	Antenna cable grommet (part of 18A984)
3	18813	Antenna mast
4	18A927	Antenna base cover
5	W710248	Antenna base screws (3 required)
6	18A984	Antenna base

#### Removal and Installation

1. Remove the antenna mast.
2. Remove the fender splash shield. For additional information, refer to Section 501-02.

3. Lower the glove compartment door.
4. Disconnect the antenna in-line connector.
5. Push the antenna cable grommet through the bulkhead.
6. Remove the antenna base cover.
7. Remove the 3 screws and the antenna base and cable.
8. To install, reverse the removal procedure.

## REMOVAL AND INSTALLATION

### Antenna Lead-In Cable

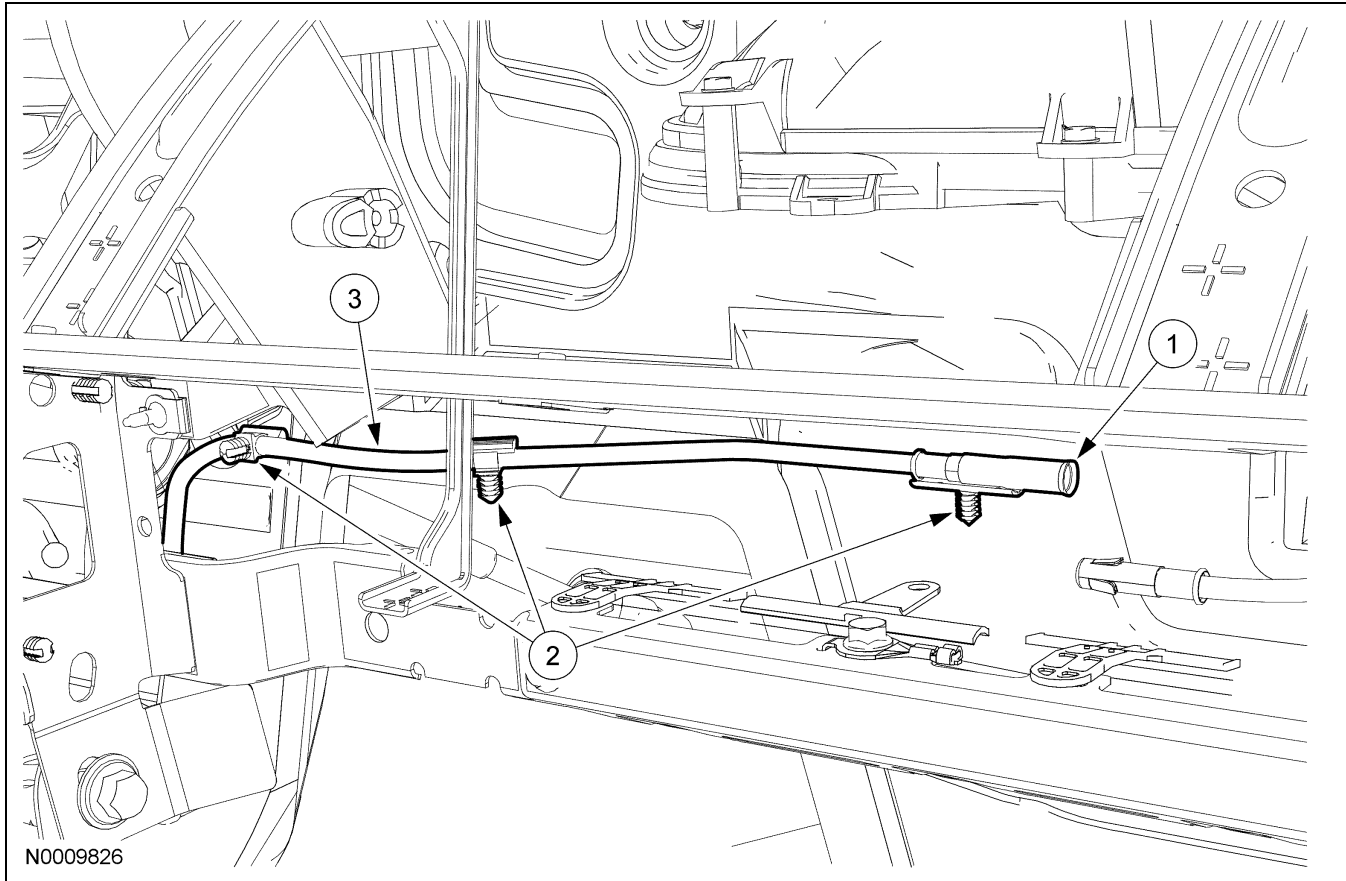

Item	Part Number	Description
1	19A136	Antenna in-line connector
2	—	Pin-type retainers (part of 18812)
3	18812	Antenna lead-in cable

2. Lower the glove compartment door.
3. Disconnect the antenna in-line connector.
4. Disconnect the pin-type retainers and remove the antenna lead-in cable.
5. To install, reverse the removal procedure.

### Removal and Installation

1. Remove the Audio Control Module (ACM). For additional information, refer to Audio Control Module (ACM) in this section.

## REMOVAL AND INSTALLATION

### Audio Control Module (ACM)

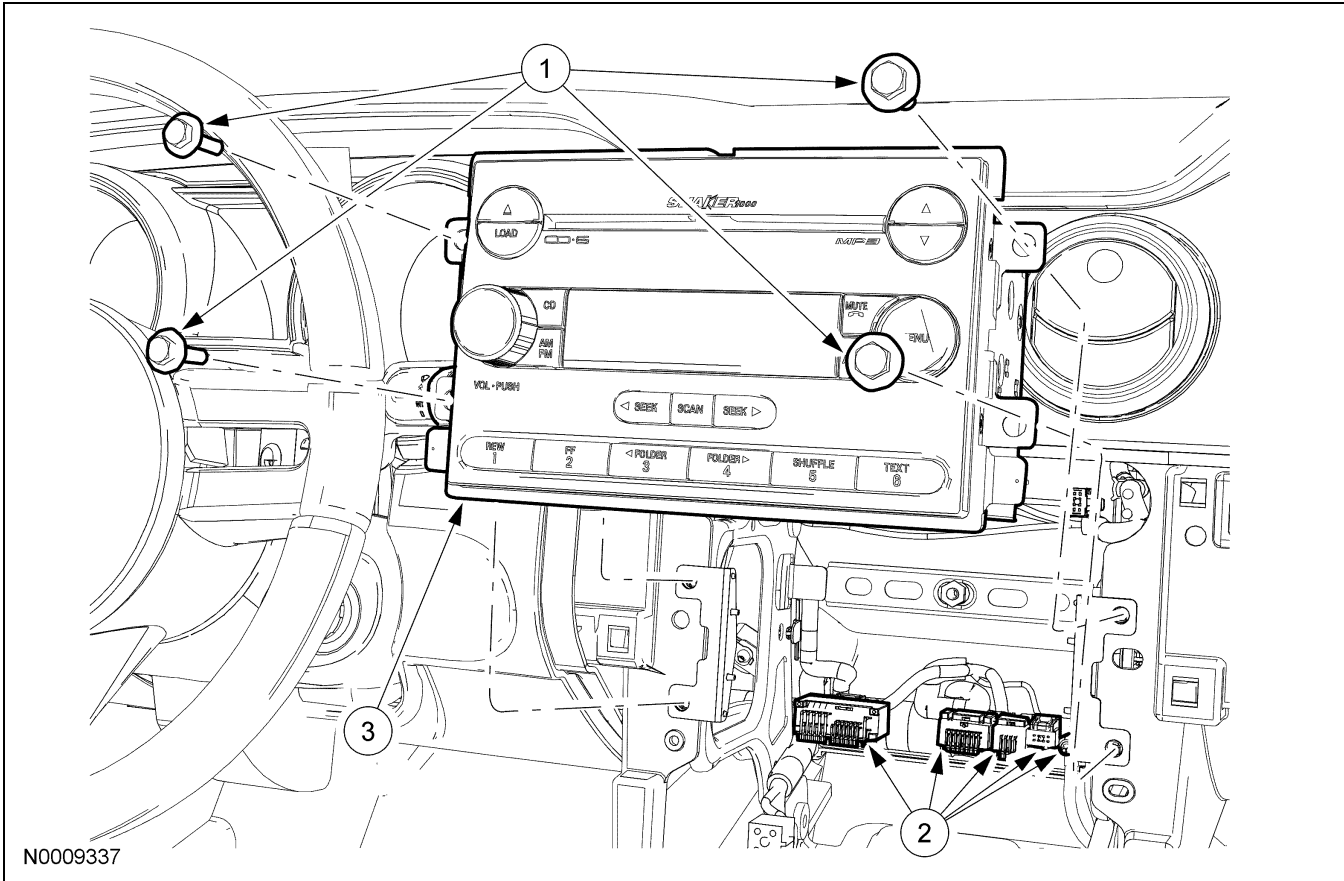

Item	Part Number	Description
1	W705314S	Audio Control Module (ACM) screws (4 required)
2	—	ACM electrical connectors (part of 14401)
3	18C815	ACM

#### Removal and Installation

**NOTE:** It is not necessary to remove the Audio Control Module (ACM) to retrieve the part number. For additional information, refer to Audio Unit Part Number Retrieval in this section.

**NOTE:** If installing a new navigation ACM, remove the navigation DVD, if possible, before sending the ACM to an authorized audio system repair facility.

1. **NOTE:** Module configuration is only required if a new ACM is being installed.

Upload the ACM configuration information to the scan tool. For additional information, refer to Section 418-01, to carry out Programmable Module Installation (PMI).

2. Remove the instrument panel center finish panel. For additional information, refer to Section 501-12.
3. Remove the 4 screws and the ACM.
  - Disconnect the electrical connectors and the antenna lead-in cable.
4. To install, reverse the removal procedure.
  - Download the configuration information to the ACM. For additional information, refer to Section 418-01, to carry out PMI.

## REMOVAL AND INSTALLATION

### Door Speaker

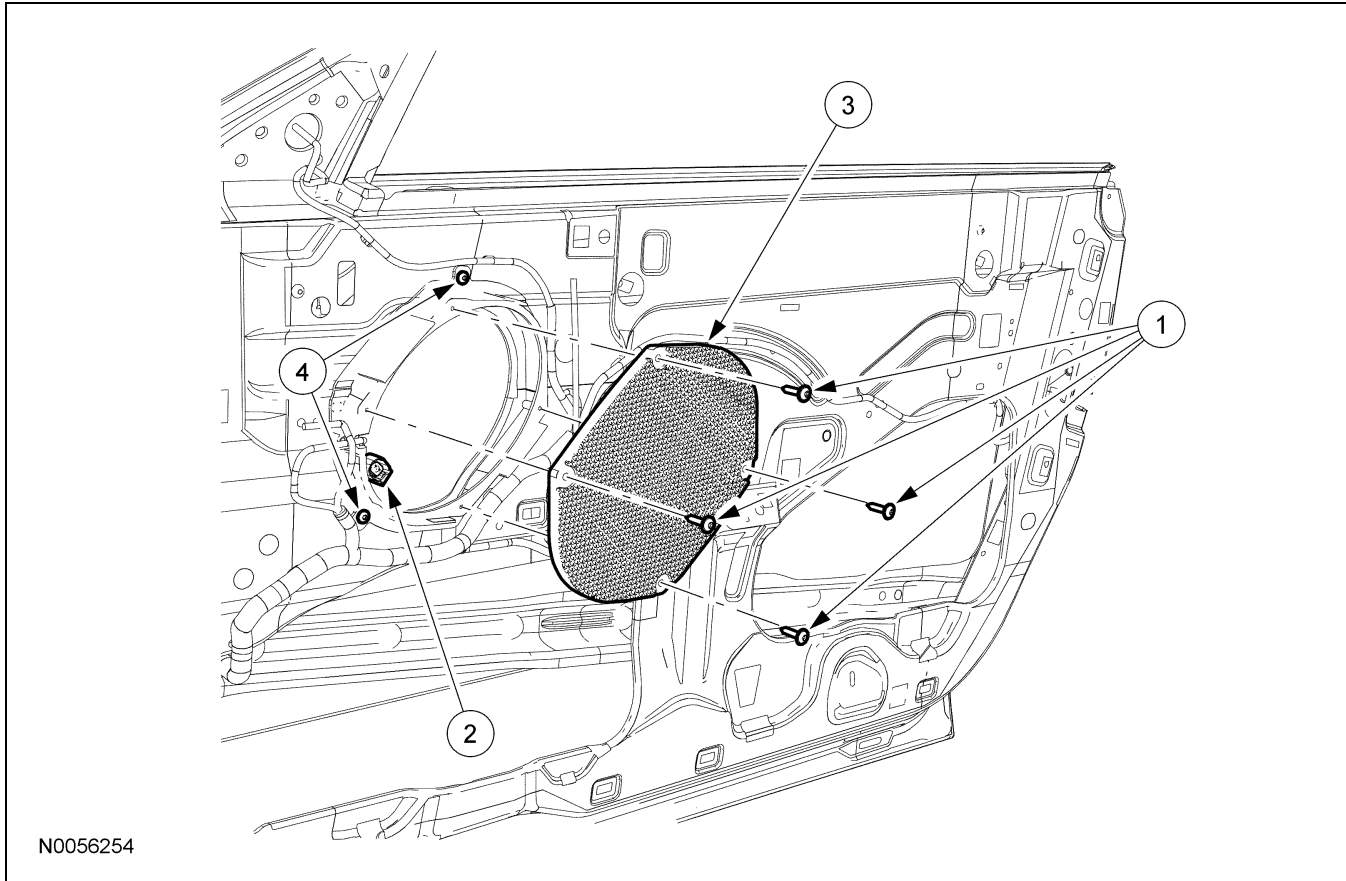

Item	Part Number	Description
1	W709996	Door speaker screws (4 required)
2	—	Door speaker electrical connector (part of 14630/14631)
3	18808	Door speaker
4	W701930	Door speaker mounting bracket screws (3 required)

#### Removal and Installation

1. Remove the door trim panel. For additional information, refer to Section 501-05.
2. Remove the 4 screws and the door speaker.
  - Disconnect the electrical connector.
3. To install, reverse the removal procedure.

## REMOVAL AND INSTALLATION

### Global Positioning System (GPS) Antenna

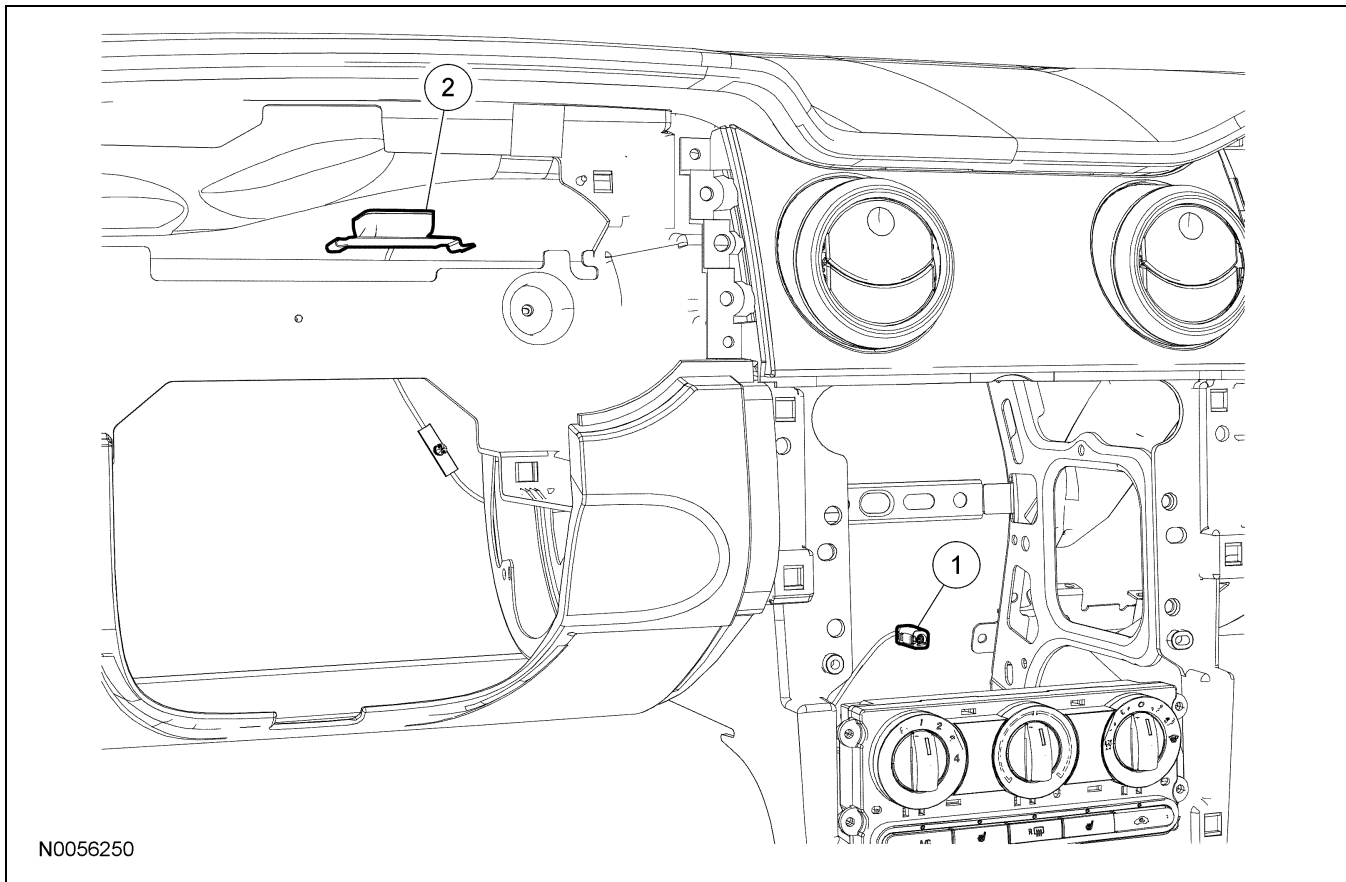

Item	Part Number	Description
1	—	Global Positioning System (GPS) antenna-to-Audio Control Module (ACM) electrical connector (part of 10E893)
2	10E893	GPS antenna

2. Remove the Instrument Cluster (IC). For additional information, refer to Section 413-01.
3. Release the antenna cable locators and remove the Global Positioning System (GPS) antenna.
4. To install, reverse the removal procedure.

#### Removal and Installation

1. Remove the Audio Control Module (ACM). For additional information, refer to Audio Control Module (ACM) in this section.

## REMOVAL AND INSTALLATION

### Quarter Panel Speaker

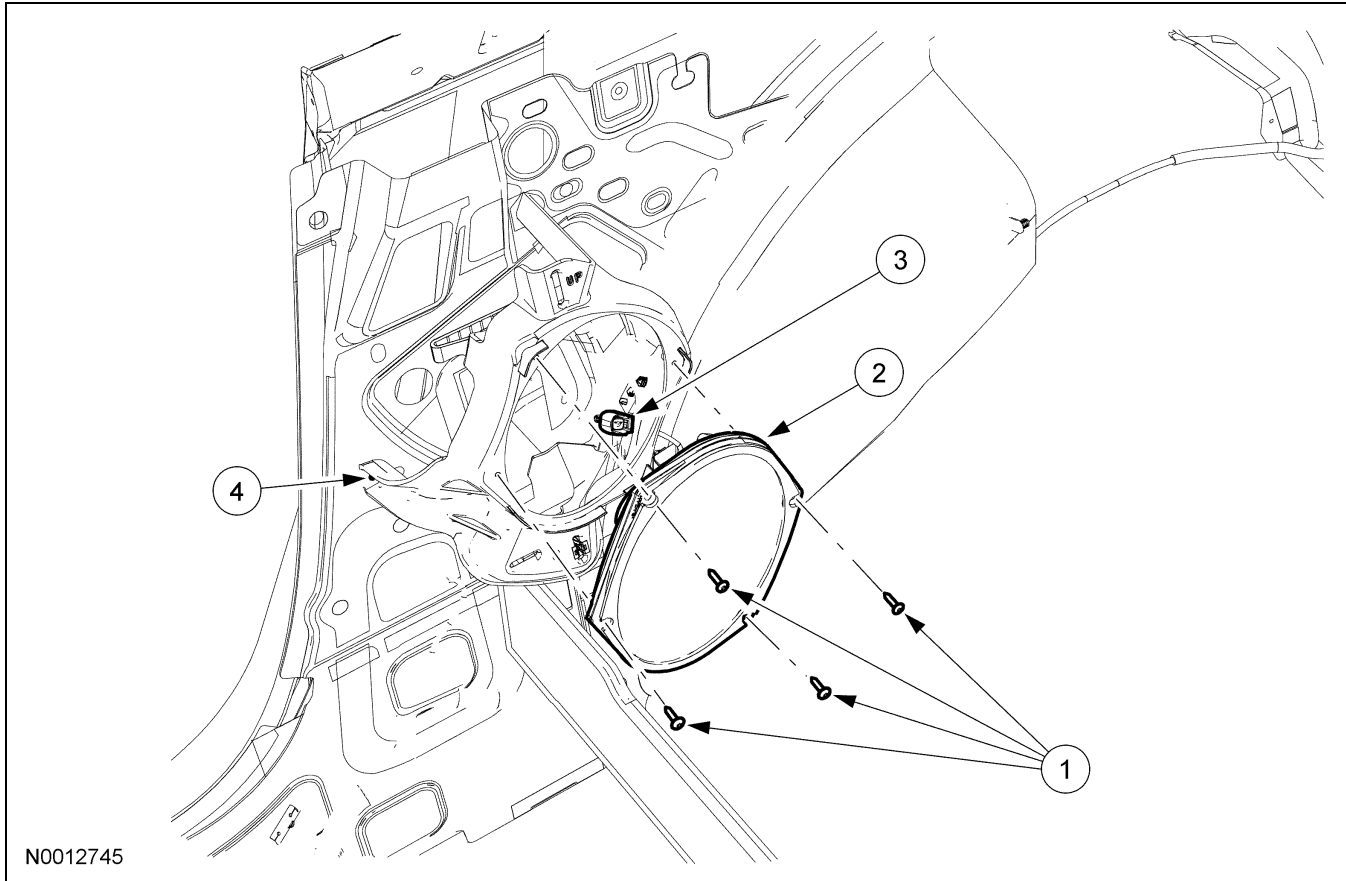

Item	Part Number	Description
1	W709996	Quarter panel speaker screws (4 required)
2	18808	Quarter panel speaker
3	—	Quarter panel speaker electrical connector (part of 14A005)
4	W701930	Quarter panel speaker mounting bracket screws (3 required)

#### Removal and Installation

1. Remove the quarter trim panel. For additional information, refer to Section 501-05.
2. Remove the 4 screws and the quarter panel speaker.
  - Disconnect the electrical connector.
3. To install, reverse the removal procedure.

## REMOVAL AND INSTALLATION

### Satellite Digital Audio Receiver System (SDARS) Module

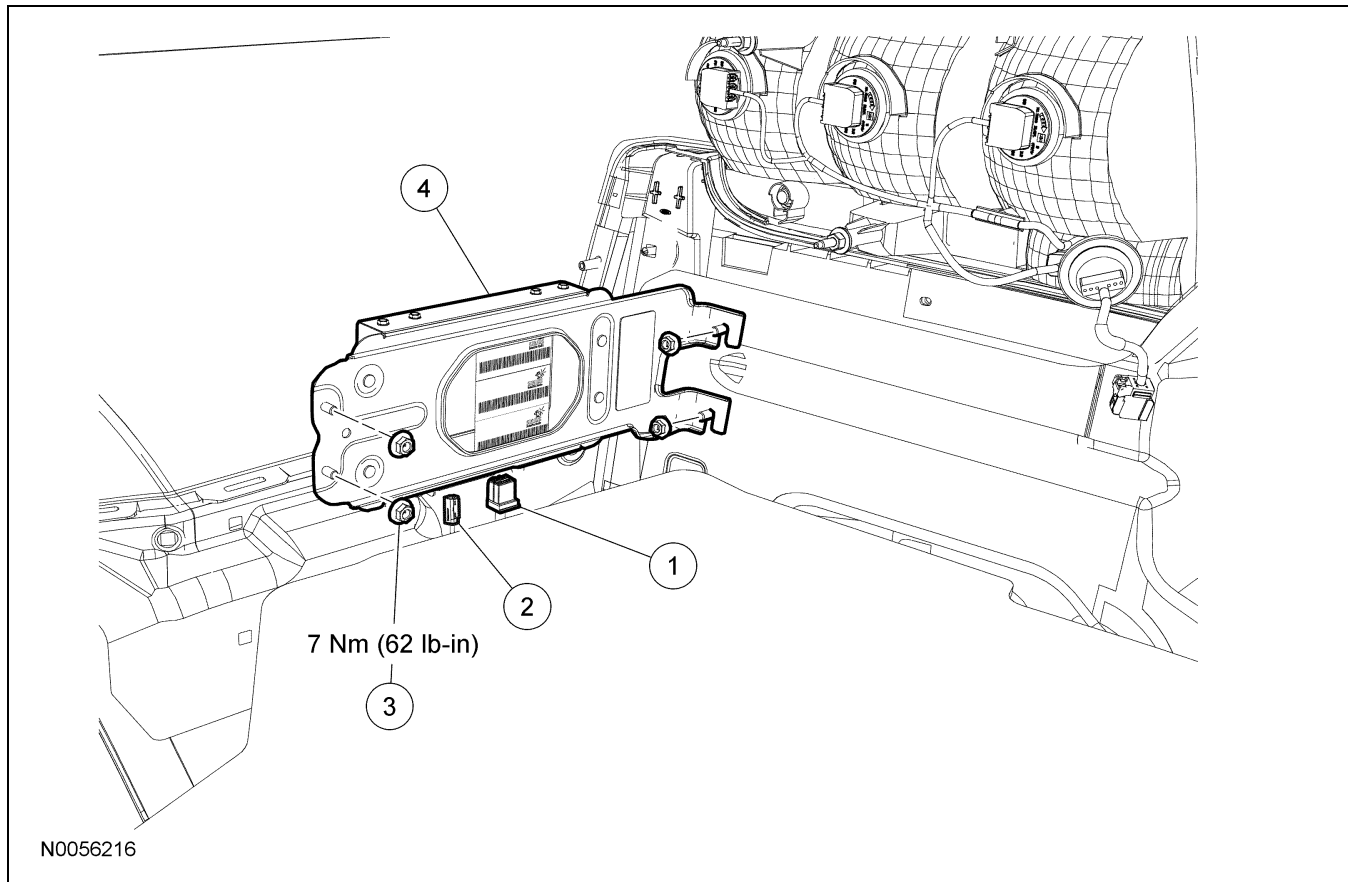

Item	Part Number	Description
1	—	Satellite Digital Audio Receiver System (SDARS) module electrical connector (part of 14A005)
2	—	Satellite radio antenna cable electrical connector (part of 19B516)
3	W520412-S	SDARS module nuts (4 required)
4	18C963	SDARS module

2. Set the RH luggage compartment trim aside.
  - Remove the push-pins, as required.
3. **NOTE:** When installing the nuts, tighten the 2 rear nuts before tightening the front 2 nuts. Remove the 4 nuts and the SDARS module.
  - Disconnect the electrical connectors.
  - To install, tighten the nuts to 7 Nm (62 lb-in).

### Removal and Installation

1. **NOTE:** Module configuration is only required if a new Satellite Digital Audio Receiver System (SDARS) module is being installed. Upload the SDARS module configuration information to the scan tool. For additional information, refer to Programmable Module Installation (PMI) in Section 418-01.

---

**REMOVAL AND INSTALLATION (Continued)**

4. To install, reverse the removal procedure.
    - Download the configuration information to the SDARS module. For additional information, refer to PMI in Section 418-01.
-

## REMOVAL AND INSTALLATION

### Speaker Enclosure

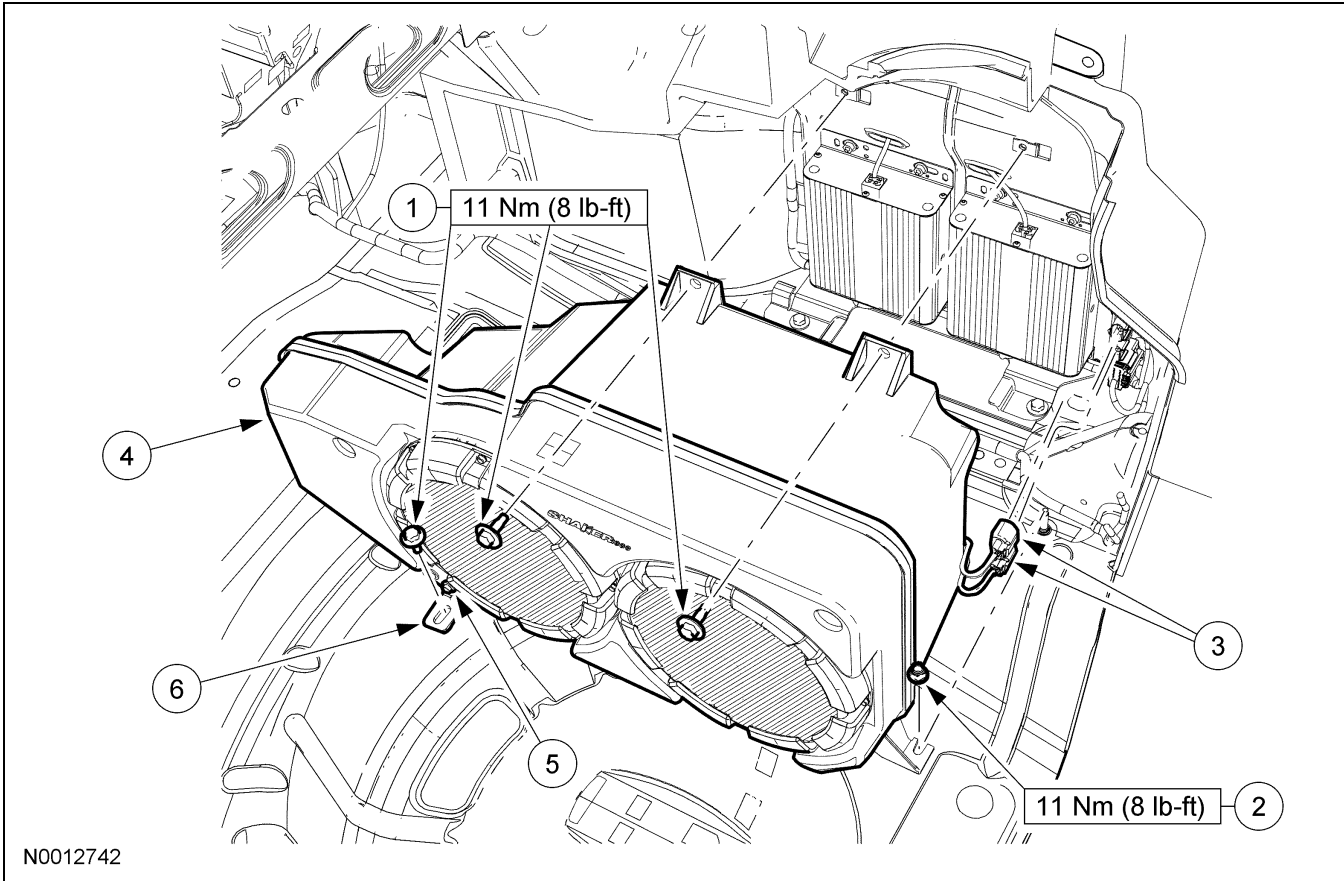

Item	Part Number	Description
1	W505433	Speaker enclosure bolts (3 required)
2	W705047	Speaker enclosure nut
3	—	Speaker enclosure electrical connectors (part of 14N128)
4	19A067	Speaker enclosure
5	W505416	L-bracket screws (2 required)
6	19B187	L-bracket

#### Removal and Installation

- Remove the 3 speaker enclosure bolts.
  - To install, tighten to 11 Nm (8 lb-ft).
- Remove the nut and the speaker enclosure.
  - To install, tighten to 11 Nm (8 lb-ft).
  - Disconnect the electrical connectors.
- To install, reverse the removal procedure.

## REMOVAL AND INSTALLATION

### Subwoofer Amplifier — Door

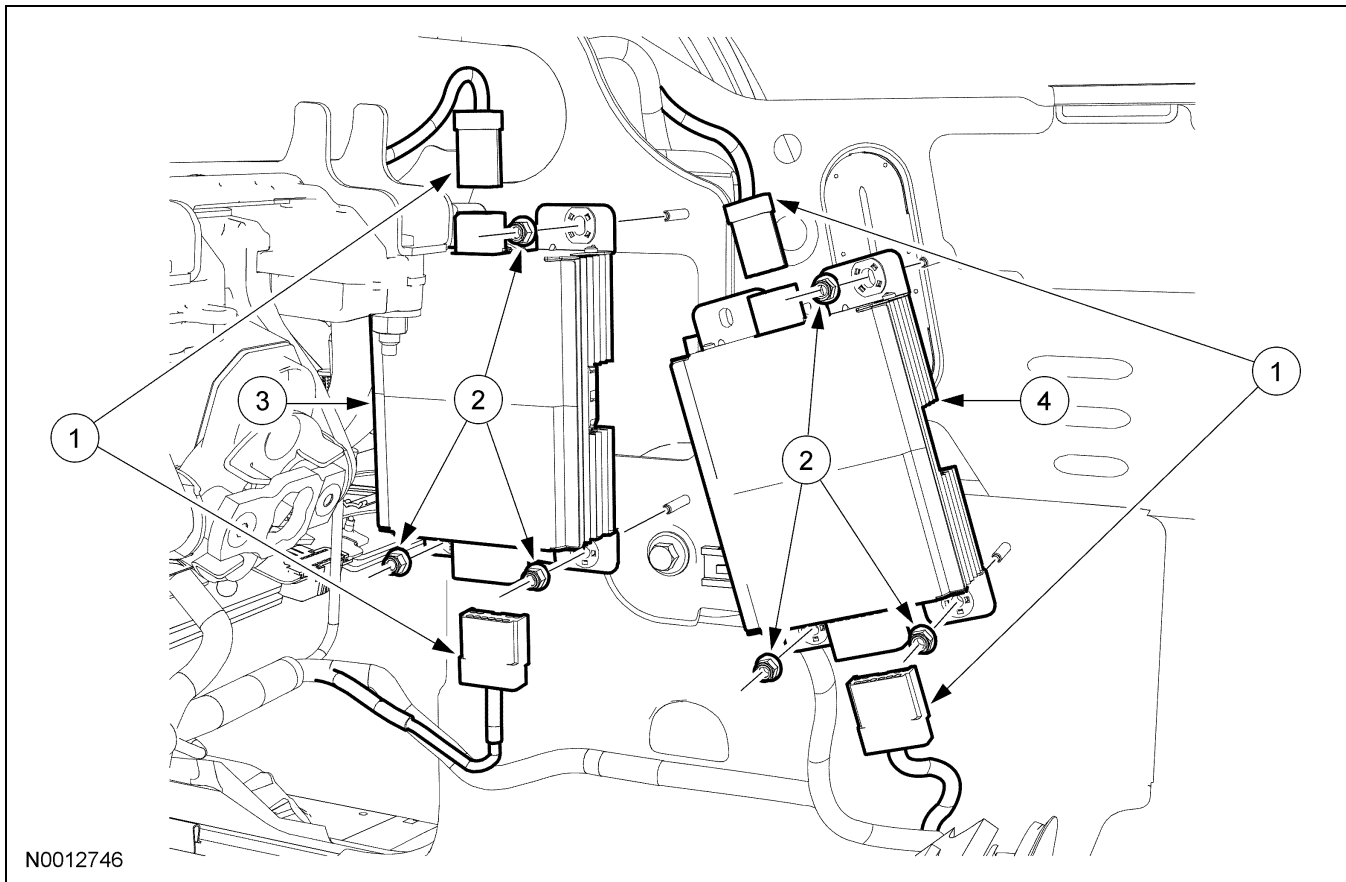

Item	Part Number	Description
1	19B113	Door subwoofer amplifier electrical connectors
2	W520210	Door subwoofer amplifier nuts (3 required per amplifier)
3	18C808	Door subwoofer amplifier (RH door)
4	18C808	Door subwoofer amplifier (LH door)

#### Removal and Installation

1. Remove the 3 nuts and the door subwoofer amplifier.
  - Disconnect the electrical connectors.
2. To install, reverse the removal procedure.

# REMOVAL AND INSTALLATION

## Subwoofer Amplifier — Luggage Compartment

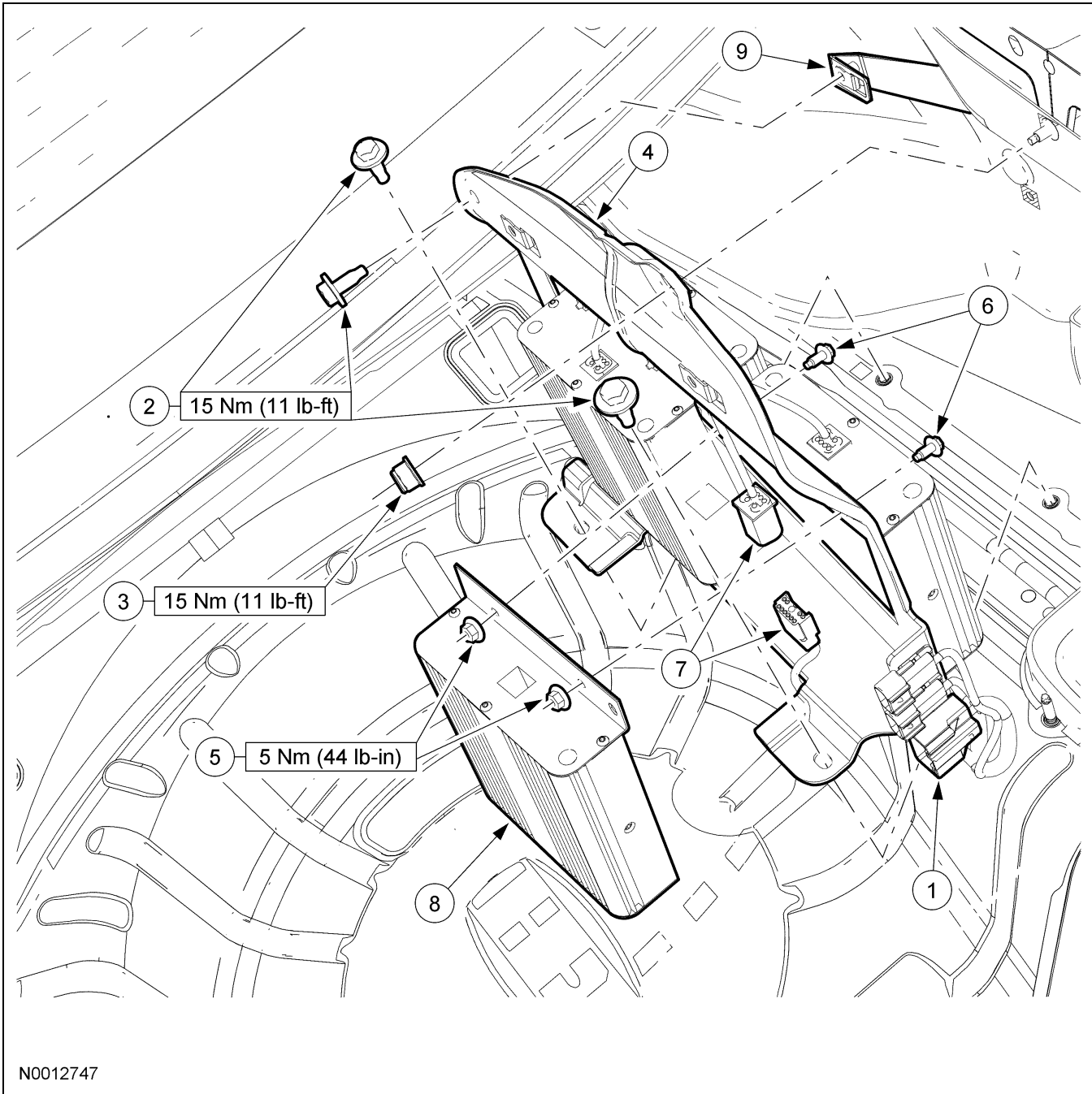

N0012747

**REMOVAL AND INSTALLATION (Continued)**

Item	Part Number	Description
1	—	Luggage compartment subwoofer amplifier jumper harness electrical connector (part of 14A005)
2	W505433	Luggage compartment subwoofer amplifier rack bolts (3 required)
3	W520212	Luggage compartment subwoofer amplifier rack nut
4	18T806	Luggage compartment subwoofer amplifier rack
5	N621903	Luggage compartment subwoofer amplifier nuts (4 required per pair of amplifiers)
6	N606663	Luggage compartment subwoofer amplifier bolts (4 required per pair of amplifiers)
7	19B113	Luggage compartment subwoofer amplifier electrical connectors
8	18C088	Luggage compartment subwoofer amplifiers
9	19B187	Attachment bracket

**Removal and Installation**

1. Remove the speaker enclosure. For additional information, refer to Speaker Enclosure in this section.
2. Disconnect the luggage compartment subwoofer amplifier jumper harness electrical connector.
3. Remove the 3 luggage compartment subwoofer amplifier rack bolts.
  - To install, tighten to 15 Nm (11 lb-ft).
4. Remove the nut and the luggage compartment subwoofer amplifier rack.
  - To install, tighten to 15 Nm (11 lb-ft).
5. Remove the 4 nuts and bolts and the pair of luggage compartment subwoofer amplifiers.
  - Disconnect the electrical connectors.
  - To install, tighten to 5 Nm (44 lb-in).
6. To install, reverse the removal procedure.

## REMOVAL AND INSTALLATION

### Subwoofer Speaker

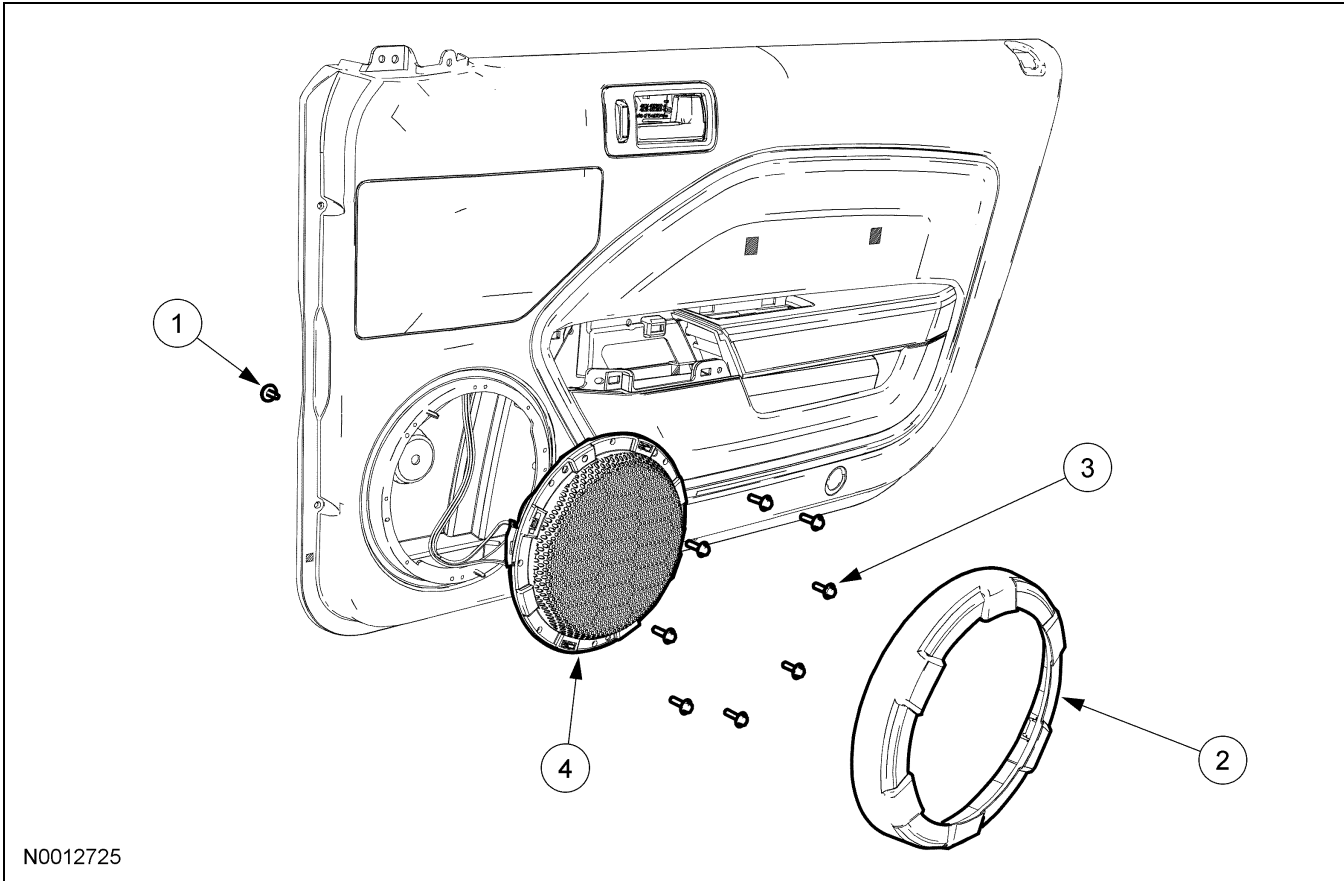

Item	Part Number	Description
1	W707281	Door subwoofer speaker bolt
2	18978	Door subwoofer speaker grille trim
3	N606674	Door subwoofer speaker screws (8 required)
4	18808	Door subwoofer speaker

#### Removal and Installation

1. Remove the door trim panel. For additional information, refer to Section 501-05.
2. Remove the door subwoofer speaker grille trim.
3. Remove the door subwoofer speaker bolt.
4. Remove the 8 screws and the door subwoofer speaker.
  - Push the wiring harness grommet through the door trim panel.
  - Disconnect the electrical connector.
5. To install, reverse the removal procedure.