

SPECIFICATIONS

Material

Item	Specification	Fill Capacity
Clear Silicone Rubber TA-32	ESB-M4G92-A	—
MERCON® V Automatic Transmission Fluid XT-5-QM (or XT-5-QMC) (US); CXT-5-LM12 (Canada)	MERCON® V	2.6L (2.8 qt)
Multi-Purpose Grease XG-4 and/or XL-5	ESB-M1C93-B	—
Premium Long-Life Grease XG-1-C or XG-1-K (US); CXG-1-C (Canada)	ESA-M1C75-B	—
Threadlock and Sealer TA-25	WSK-M2G351-A5	—
Thread Sealant with PTFE TA-24	WSK-M2G350-A2	—

General Specifications

Item	Specification
End Play	
Countershaft cluster gear end play	0.013 mm (0.0005 in) - 0.102 mm (0.0040 in)
Output shaft end play	0.03 mm (0.0010 in) - 0.230 mm (0.0090 in)
Synchronizer	
Synchronizer blocking ring-to-conical face runout	0.5 mm (0.02 in)
Transmission	
Physical weight	42 kg (93 lb)

Torque Specifications

Description	Nm	lb-ft	lb-in
Case cover bolt	12	—	106
Clutch housing bolt	63	46	—
Clutch housing cover bolt	31	23	—
Clutch slave cylinder bolt	9	—	80
Countershaft rear bearing retainer bolt	21	15	—
Crossmember bolt	62	46	—
Crossmember transmission bolt	70	52	—
Drain plug	18	—	159
Driveshaft bolt	103	76	—
Exhaust coupler	54	40	—
Extension cover bolt	19	—	168
Extension housing bolt	54	40	—
Filler plug	18	—	159
Gearshift underbody nut	11	—	97
Input shaft bearing retainer bolt	21	15	—
Output flange nut	142	105	—
Output Shaft Speed (OSS) sensor bolt	10	—	89
Overcenter spring bolt	35	26	—
Reversing lamp switch	37	27	—
Shift lever reverse pin	40	30	—
Starter bolt	25	18	—
Transmission bolt	45	33	—
Transmission mount nut	115	85	—
Transmission shift linkage bolt	40	30	—

DESCRIPTION AND OPERATION

Manual Transmission

The T5OD 5-speed transmission:

- fifth speed gear functions as an overdrive gear.
- forward gears are synchronized and helical cut.
- shift interlock system prevents the engagement of more than one gear.
- has an aluminum main case, extension housing and bellhousing.
- has an input shaft, output shaft and countershaft.
- reverse idler gear is used to produce a reverse rotation of the output shaft.

The transmission function is to move the vehicle from a rest position to motion. This is done by transferring the engine torque to the vehicle rear wheels. The transmission uses gears to adapt the torque to the demands of load and road conditions. It matches engine power to vehicle needs.

This power is delivered from the engine flywheel, to the transmission. The power is transmitted through a driver-operated clutch, which allows for engagement and disengagement of the engine to the transmission.

The transmission input shaft receives the power when the clutch is engaged. It is transferred through the input shaft to the drive gear. Torque is transferred to the countershaft drive gear and is delivered along the countershaft to all the countershaft gears. Torque is then transferred to the engaged mainshaft gear. The transmission then uses a system of mainshaft gears to change the speed and torque relationship between the engine crankshaft and the transmission output shaft.

Transmission Identification

The transmission identification tag is located under the lower left bolt that retains the extension housing to the case.

The T5OD transmission is available for the Mustang 4.0L SOHC.

Transmission Identification Tag

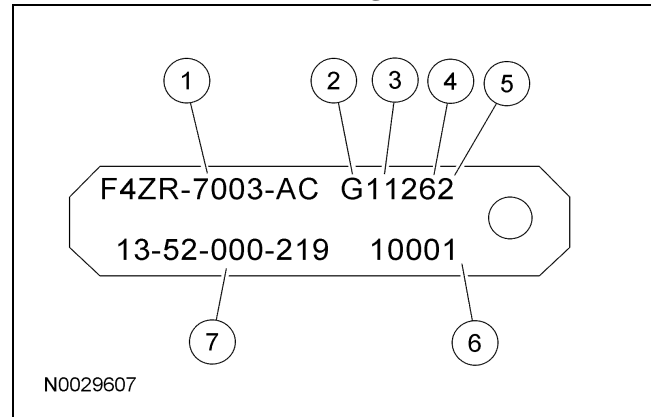

Item	Part Number	Description
1	—	Transmission assembly number
2	—	Build date code — month
3	—	Build date code — day
4	—	Build date code — year
5	—	Shift number
6	—	Serial number
7	—	Identification number (Located on the extension housing bolt on the LH side of the transmission)

DIAGNOSIS AND TESTING

Manual Transmission

Refer to Section 308-00.

GENERAL PROCEDURES

Transmission Draining and Filling

Special Tool(s)

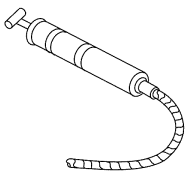
 <p style="text-align: center;">ST1526-A</p>	<p>Oil Suction Gun 303-D104 (D94T-9000-A) or equivalent</p>
---	---

Material

Item	Specification
<p>MERCON® V Automatic Transmission Fluid XT-5-QM (or XT-5-QMC) (US); CXT-5-LM12 (Canada)</p>	<p>MERCON® V</p>
<p>Thread Sealant with PTFE TA-24</p>	<p>WSK-M2G350-A2</p>

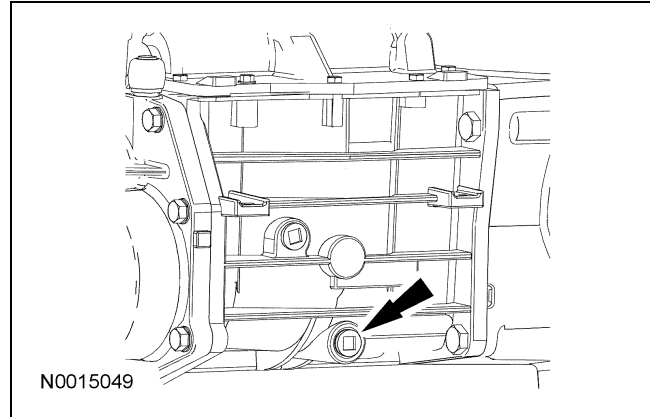

3. Clean the drain plug. Apply thread sealant and reinstall.
 - Tighten to 18 Nm (159 lb-in).
4. **NOTE:** Prior to removal, clean the area around the filler plug.
Remove the filler plug.

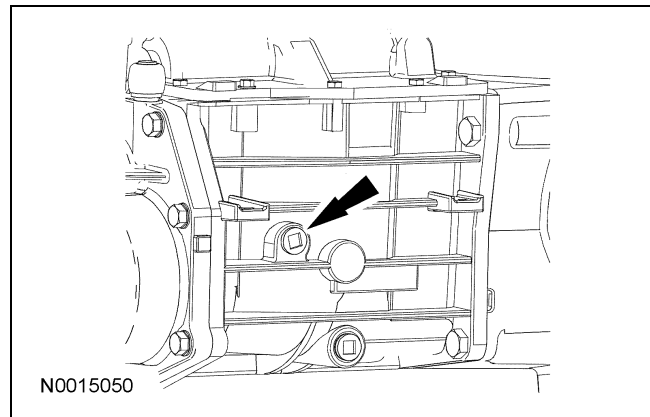
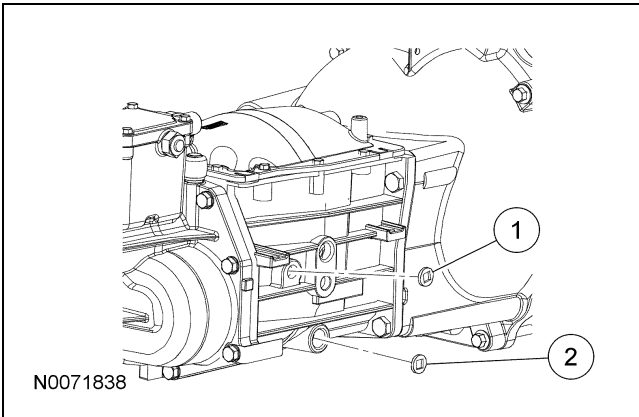

Item	Part Number	Description
1	7A010	Filler plug
2	7A010	Drain plug

1. With the vehicle in NEUTRAL, position it on a hoist. For additional information, refer to Section 100-02.
2. **NOTE:** Drain the transmission while the transmission fluid is warm.
NOTE: Position a drain pan under the transmission.
Remove the drain plug and drain the fluid.

GENERAL PROCEDURES (Continued)

5. **NOTE:** Do not overfill the transmission. This will cause transmission fluid to be forced out of the case.

Using an Oil Suction Gun, fill the transmission with the recommended fluid.

- Transmission capacity is 2.6L (2.8 qt).

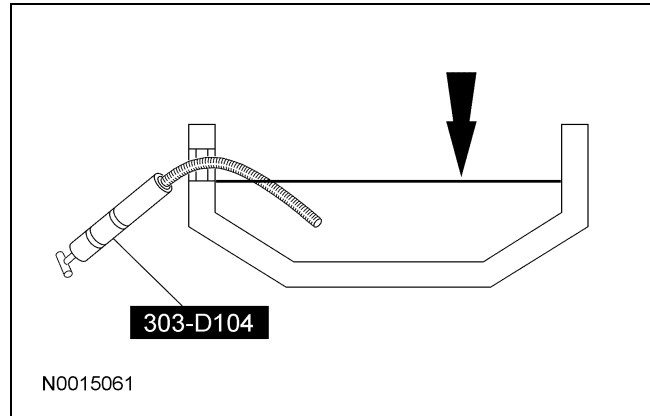

6. Clean the filler plug. Apply thread sealant and reinstall.
- Tighten to 18 Nm (159 lb-in).
-

REMOVAL AND INSTALLATION

Transmission

NOTE: Do not separate the transmission from the clutch housing. Remove the transmission and clutch housing as an assembly.

1. With the vehicle in **NEUTRAL**, position it on a hoist. For additional information, refer to Section 100-02.
2. Disconnect the battery ground cable. For additional information, refer to Section 414-01.
3. **NOTE:** Index-mark the driveshaft to the output shaft flange.

Remove the 4 driveshaft bolts and separate the driveshaft from the output flange. Position the driveshaft aside.

- Using mechanic's wire, support the driveshaft.

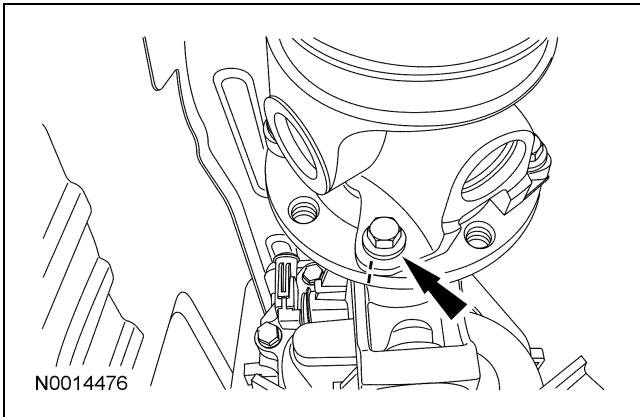

4. Remove the shift linkage bolt and the shift linkage nut. Disconnect the shift linkage from the transmission.

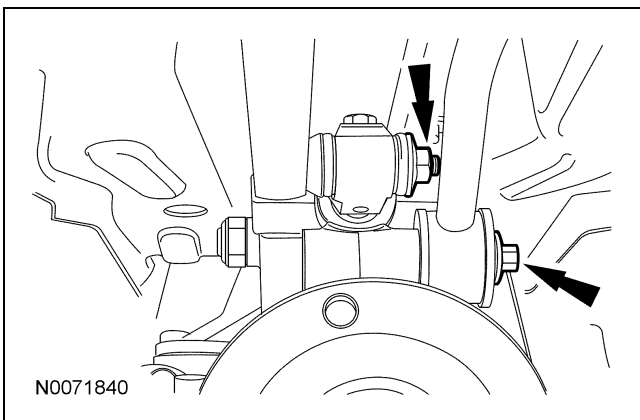

5. Separate the wiring harness from the transmission. Disconnect the following:
 - Catalyst monitor sensor electrical connector
 - Reverse lamp switch electrical connector
 - Wiring harness clips
 - Output Shaft Speed (OSS) sensor electrical connector

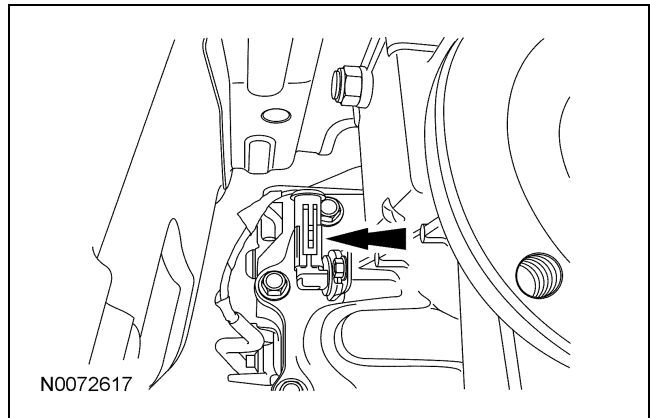
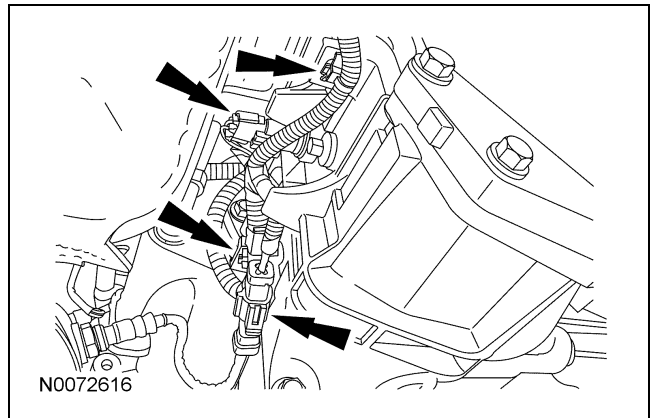

REMOVAL AND INSTALLATION (Continued)

6. Remove the 2 starter motor bolts and the starter motor. Position the starter motor aside.
 - Using mechanic's wire, support the starter motor.

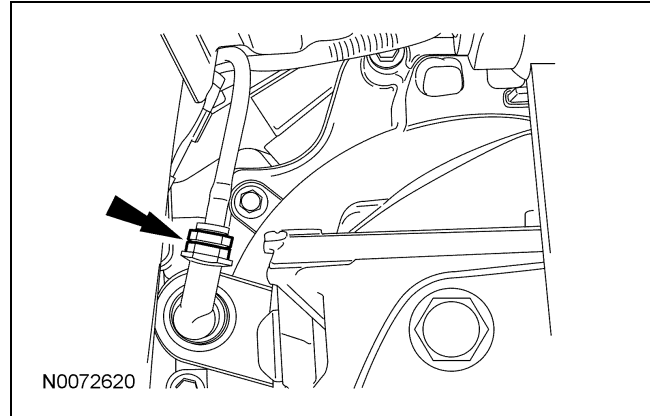
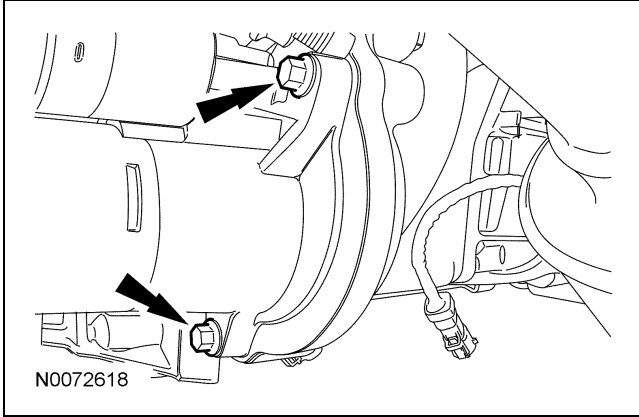

9. Loosen the exhaust coupler and disconnect the intermediate pipe from the catalytic converter. Discard the exhaust coupler.

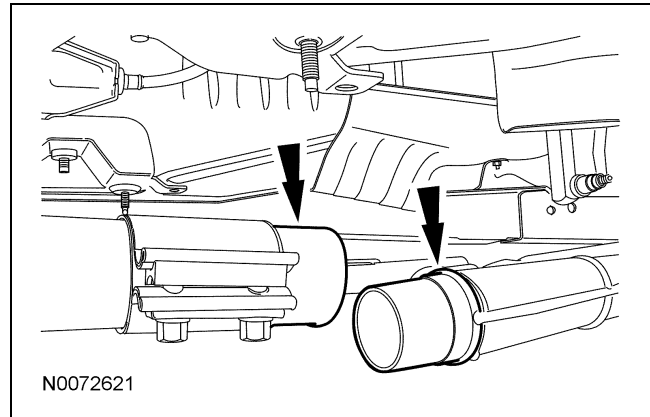



7. **NOTE:** Take note that the hump side of the crossmember goes down.
Remove the crossmember. For additional information, refer to Section 502-00.
8. Release the clutch hydraulic tube clip and separate the connector from the clutch slave cylinder.

10. Remove the 8 transmission-to-engine bolts and the separator plate bolt.
11. Pull the transmission rearward until the input shaft is clear of the pressure plate, then lower the transmission from the vehicle.

DISASSEMBLY AND ASSEMBLY

Transmission

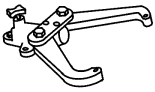
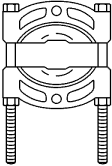
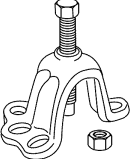
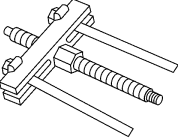
Special Tool(s)

 <p>ST1186-A</p>	<p>Holding Fixture, Transmission 307-003 (T57L-500-B)</p>
 <p>ST1368-A</p>	<p>Puller, Bearing 205-D064 (D84L-1123-A) or equivalent</p>
 <p>ST2272-A</p>	<p>Remover, Front Wheel Hub 205-D070 (D93P-1175-B) or equivalent</p>
 <p>ST1516-A</p>	<p>Remover/Installer, Front Wheel Hub 204-069 (T81P-1104-C)</p>
 <p>ST1302-A</p>	<p>Staking Tool, Locknut 308-056 (T77J-7025-F)</p>

1. Remove the clutch slave cylinder and the retaining clip. Discard the retaining clip.

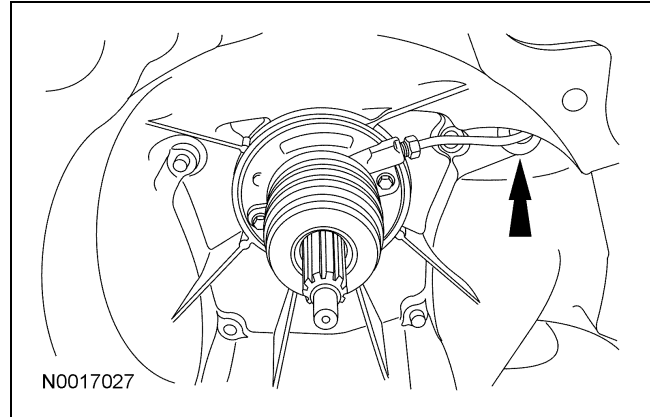

2. Remove the 4 clutch housing bolts.
 - Separate the clutch housing from the transmission.

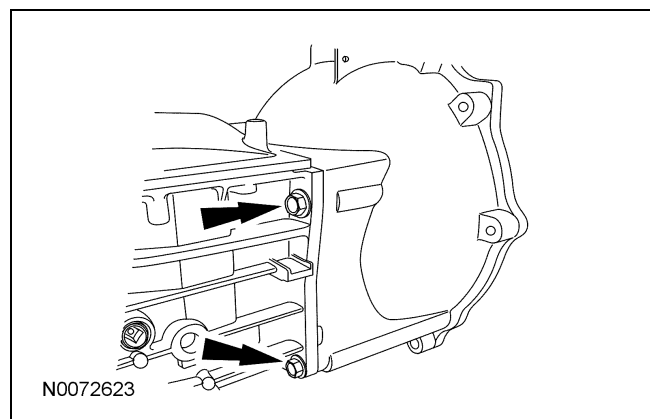
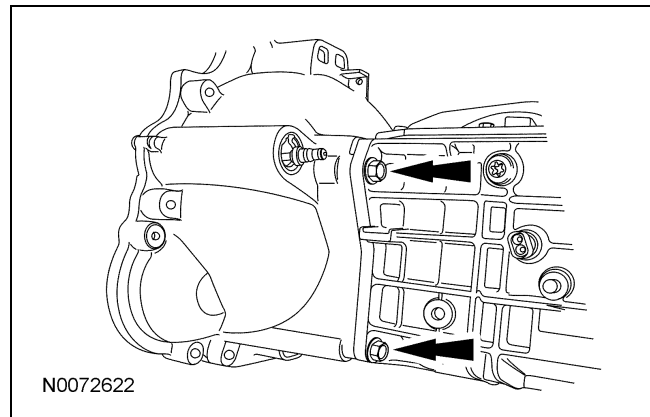

3. Clean the transmission exterior with solvent and dry with compressed air. During disassembly, clean all components with solvent and dry with compressed air.

DISASSEMBLY AND ASSEMBLY (Continued)

4. **NOTE:** Position the gearshift lever in NEUTRAL.

Attach the transmission to the Transmission Holding Fixture.

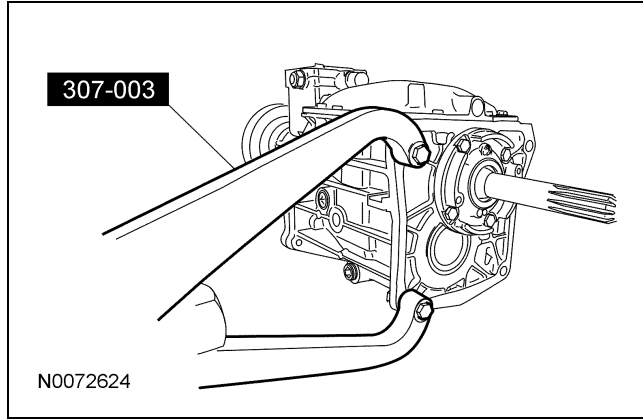

7. Remove the Output Shaft Speed (OSS) sensor.

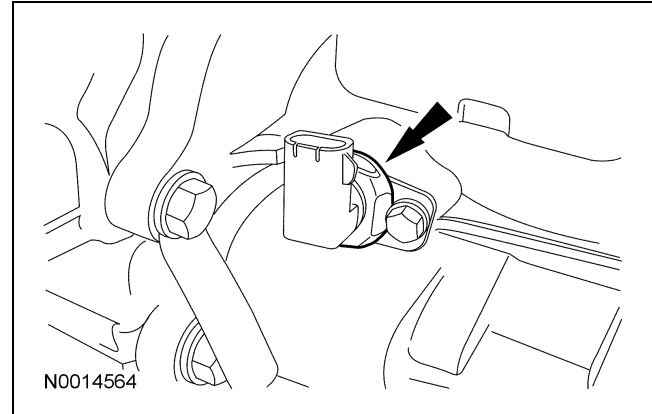

5. Remove the drain plug and drain the transmission fluid.

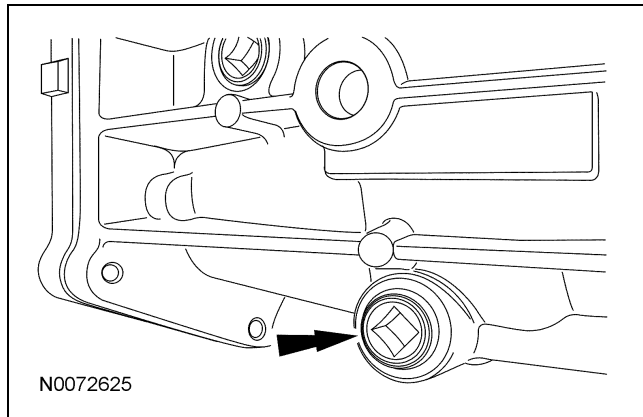

8. Remove the 4 bolts and pry the shift cover plate off.

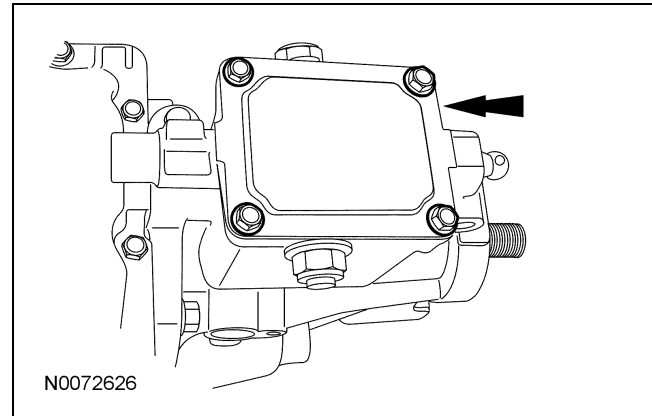

6. Remove the output shaft flange nut. Using the Front Wheel Hub Remover, remove the output shaft flange, the washer and the seal. Discard the seal.

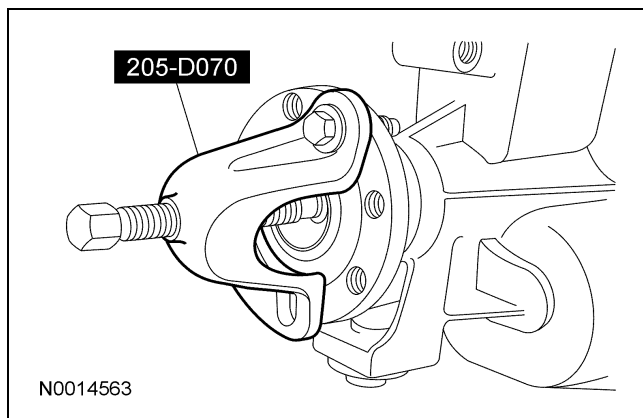

9. **NOTICE:** Do not attempt to remove the gearshift offset lever with the extension housing bolted in place. A lug, located on the bottom of the gearshift offset lever, meshes with the detent plate preventing enough rearward movement of the gearshift offset lever to allow removal.

Using a suitable punch, remove the roll pin and discard.

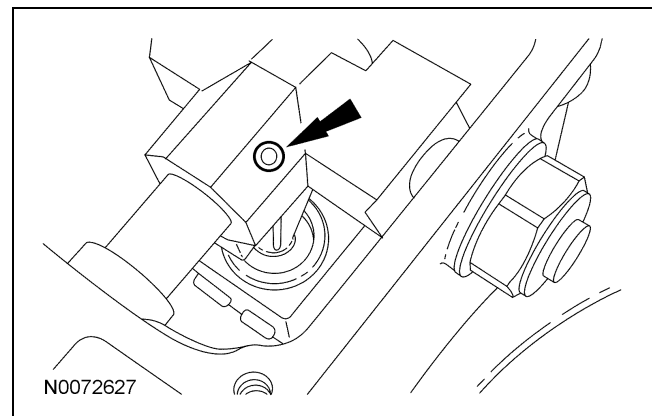

DISASSEMBLY AND ASSEMBLY (Continued)

10. Remove the 2 shift detents.

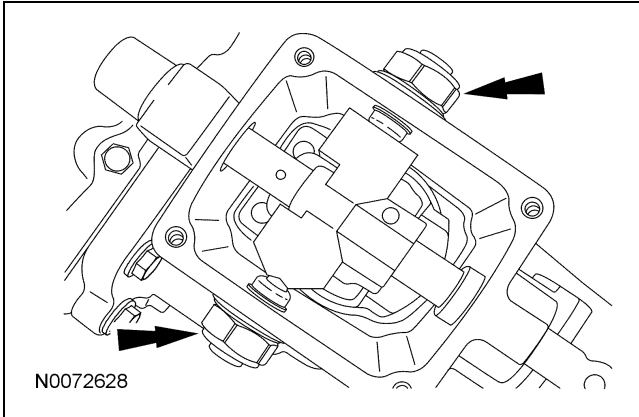

11. Move the gearshift shaft rearward, then remove the shift lever. Remove the gearshift shaft.

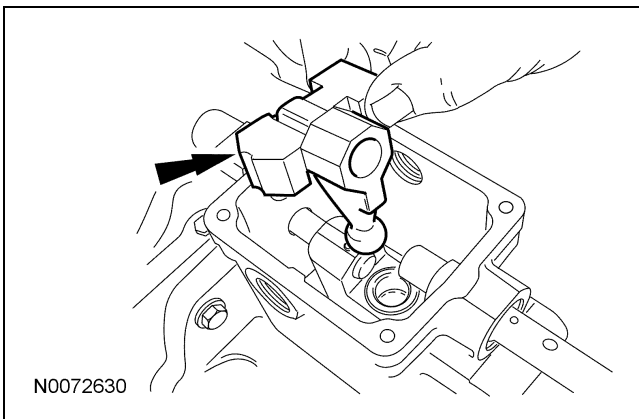
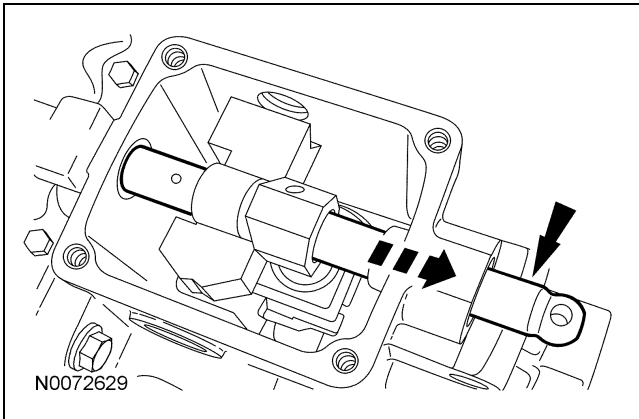

12. Using a suitable punch, remove the gearshift offset lever roll pin and discard.

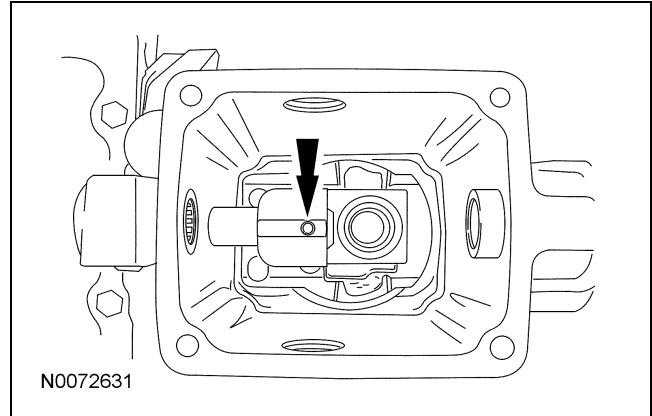

13. Remove the 7 extension housing bolts and the identification tag.

- Carefully pry the extension housing to break the gasket seal.

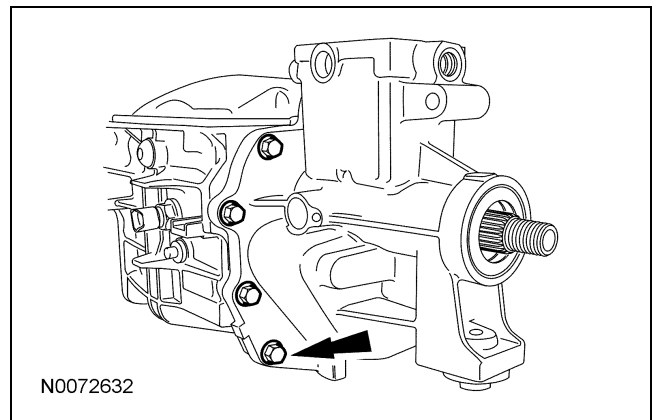

14. Remove the extension housing and the gearshift offset lever as an assembly.

15. Remove the gearshift offset lever and the split pin.

16. Using a hammer and a drift, remove the output shaft seal from the inside. Discard the seal.

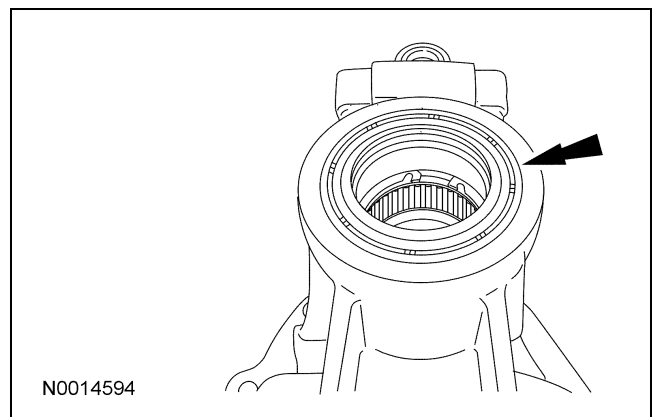

DISASSEMBLY AND ASSEMBLY (Continued)

17. Remove and discard the snap ring, then using a hammer and a drift, remove the output shaft bearing.

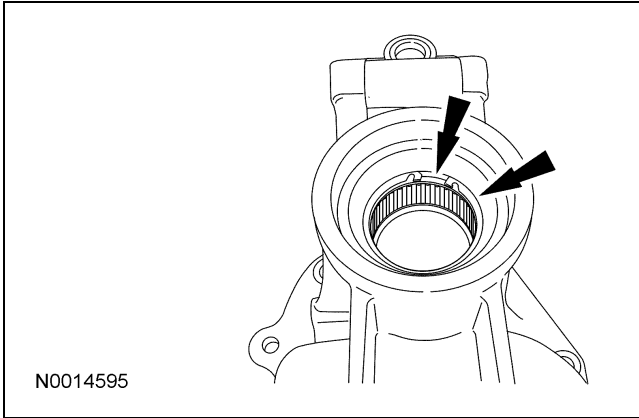

18. Remove the small output shaft spacer.

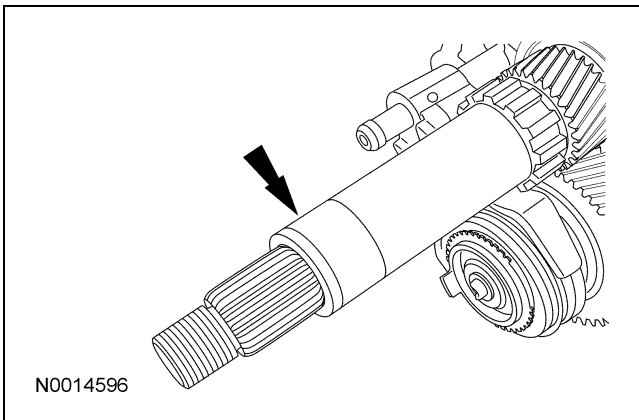

19. Remove the check ball.

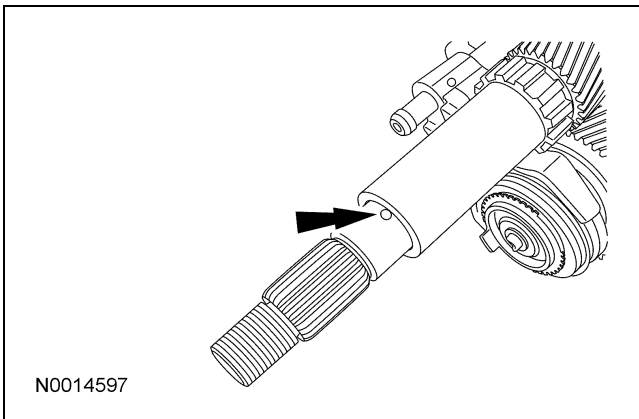

20. Remove the large output shaft spacer.

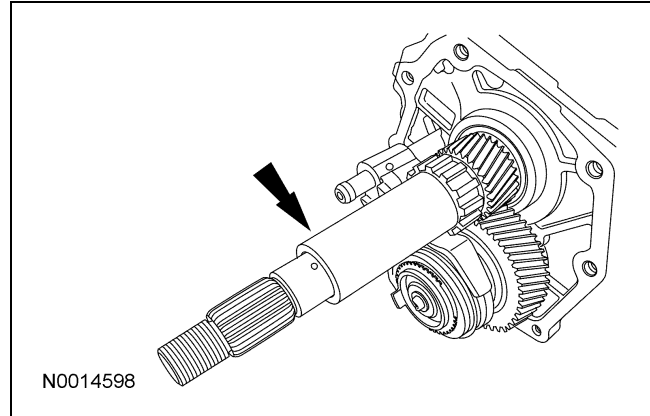

21. **NOTICE:** Support the reverse gear shift rail with a block of wood to prevent damaging the shift rail.

Remove the roll pin and discard.

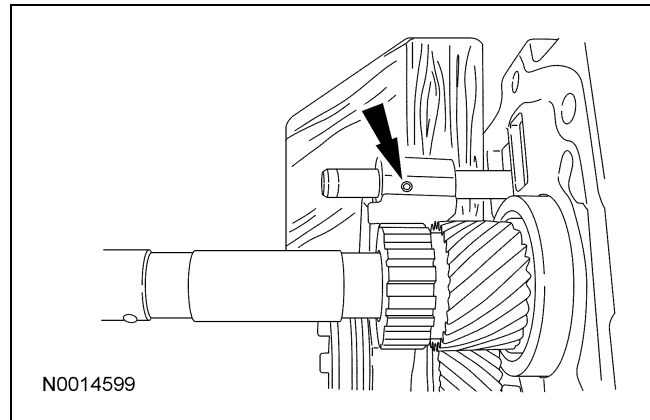

22. Remove the 10 case cover bolts. Carefully pry the case cover to break the gasket seal. Lift the case cover and slide it toward the filler plug side of the case to clear the reverse gearshift lever.

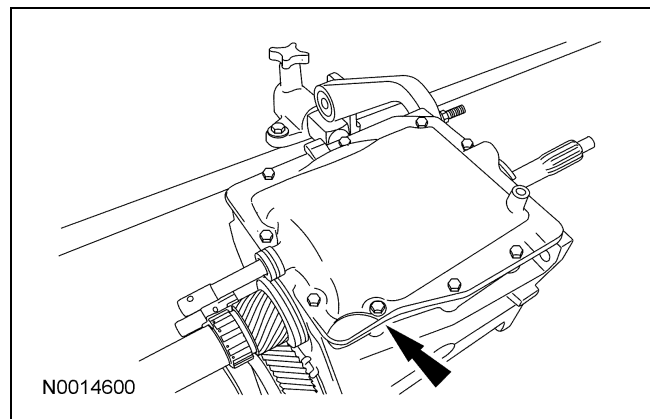

23. Rotate the transmission with the output shaft facing upward.

DISASSEMBLY AND ASSEMBLY (Continued)

24. Remove the 5th speed synchronizer snap ring, the thrust washer, the reverse brake ring and the synchronizer blocking ring.
25. Remove the 5th speed cluster gear, the synchronizer blocking ring, the synchronizer assembly and the 5th gear shifter fork as an assembly.

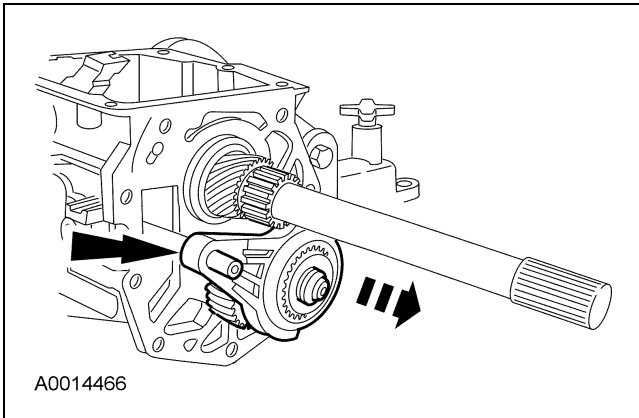

26. Rotate the reverse gear shift rail clockwise to disengage the ball stud from the reverse gearshift lever. Pull the reverse gear shift rail rearward slightly. Rotate the reverse gear shift rail counterclockwise to align the ball stud with the slot in the case and remove the reverse gear shift rail.
27. Loosen the rear bearing cup in the case. Pull upward on the mainshaft and remove the 5th gear.
28. Rotate the transmission with the input shaft facing upward.
29. **NOTE:** The input shaft bearing retainer is notched. Carefully pry the retainer to break the gasket seal.
Remove the 4 input shaft bearing retainer bolts and the input shaft bearing retainer.
30. **NOTE:** Make sure not to drop the 15 roller bearings, the input shaft bearing spacer, the thrust bearing or thrust washer from the rear of the input shaft when removing.
NOTE: Rotate the input shaft until the flat on the 4th gear clutching teeth align with the countershaft cluster gear.
Remove the input shaft.

31. Remove the 4th gear synchronizer ring, the thrust washer, the thrust bearing, the input shaft bearing spacer and the 15 roller bearings.

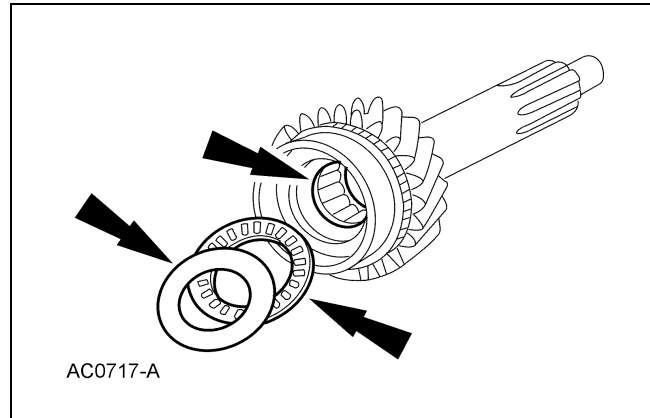

32. **NOTE:** If the output shaft rear bearing cup sticks, it is misaligned in the case bore. To free the output shaft rear bearing cup, work the output shaft assembly back and forth in the case.

Remove the output shaft rear bearing cup.

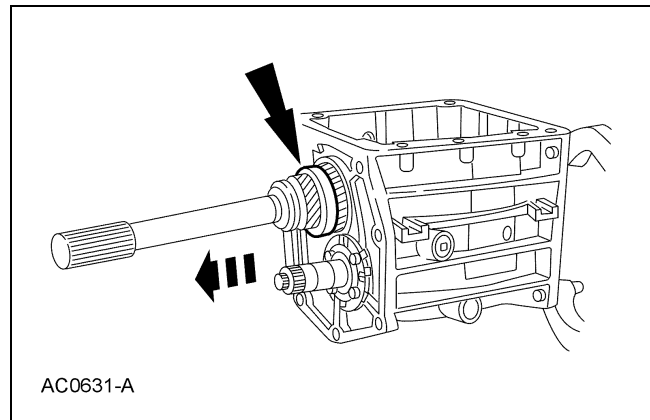

33. Remove the output shaft assembly.

DISASSEMBLY AND ASSEMBLY (Continued)

34. Using the Locknut Staking Tool, flatten the tabs on the countershaft rear bearing retainer.

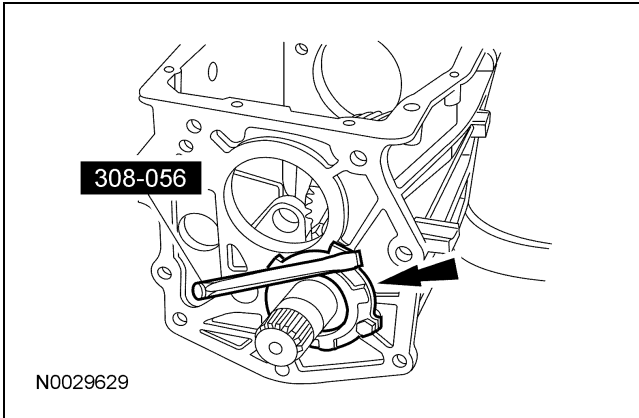

35. Remove the 4 bolts, the countershaft rear bearing retainer and the shim.

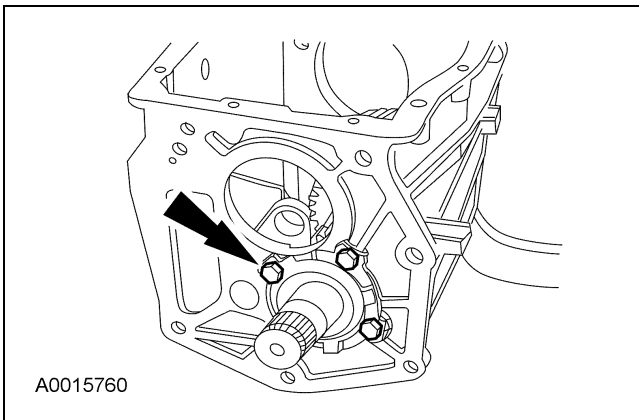

36. **NOTE:** If the bearing race sticks in the case, it is misaligned in the case bore. To free the race, work the countershaft cluster gear back and forth.

Remove the bearing race.

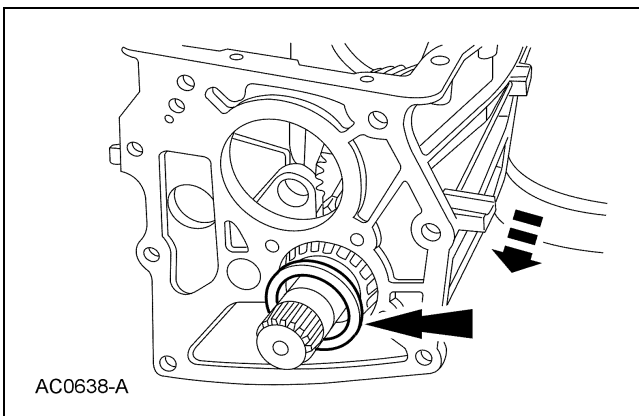

37. Using the Front Wheel Hub Remover/Installer and Bearing Puller, remove the rear countershaft bearing assembly.

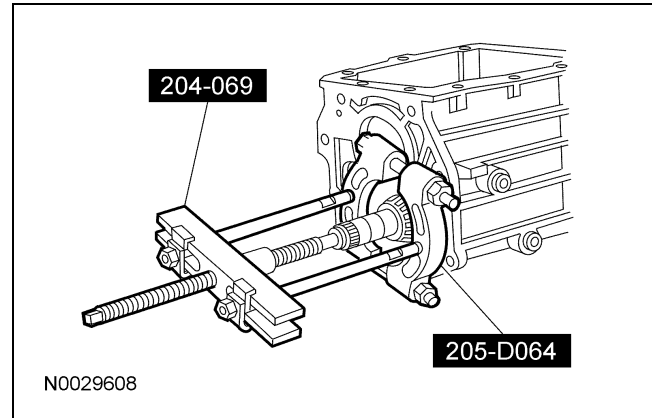

38. Remove the reverse gearshift lever retaining clip.

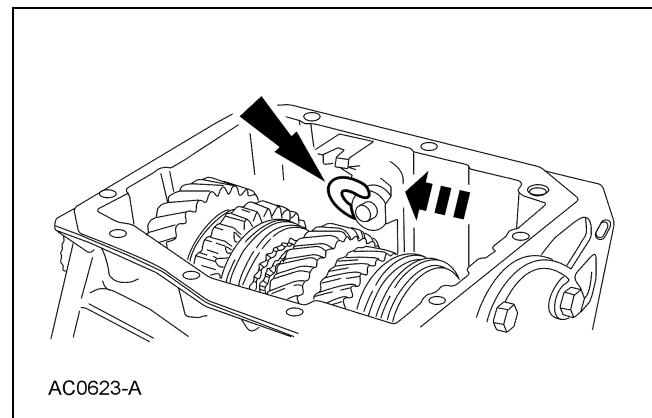

39. Using a Torx bit driver, remove the shift lever reverse pin.

40. Remove the reversing lamp switch.

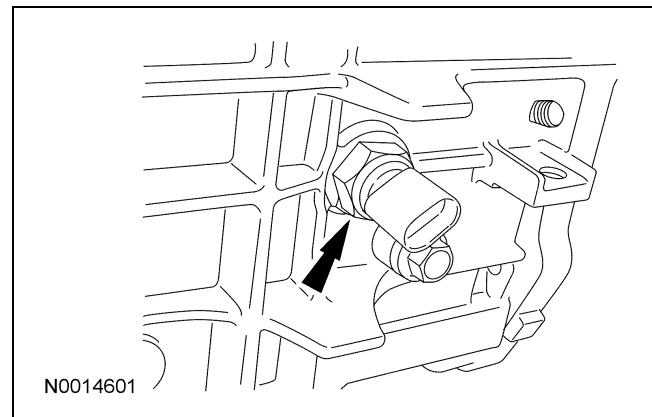

DISASSEMBLY AND ASSEMBLY (Continued)

41. **NOTE:** Observe the location of the reverse gearshift lever, the reverse shift fork and the reverse positioning spring.

NOTE: Observe the rotation action of the reverse positioning spring.

NOTE: Hold the reverse gearshift lever and lift it upward as straight up as possible to remove the assembly.

Remove the reverse gearshift lever, the reverse shift fork and the reverse positioning spring as an assembly.

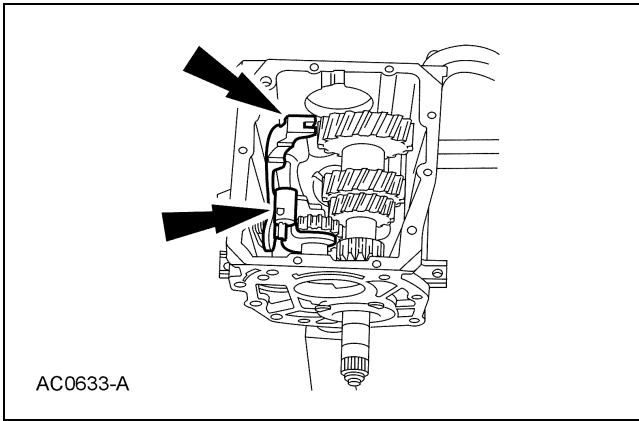
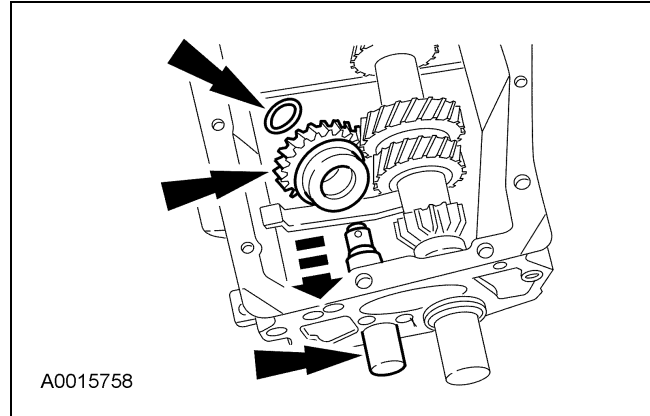

44. Move the countershaft cluster gear rearward through the bearing bore. Tilt the assembly upward and remove it from the case.

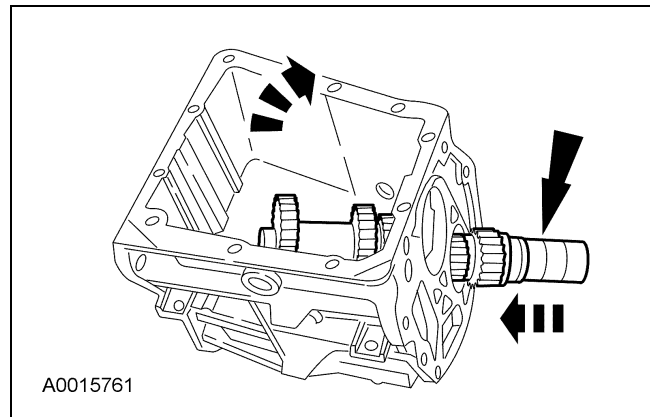

42. Using a suitable punch, remove the roll pin and discard.

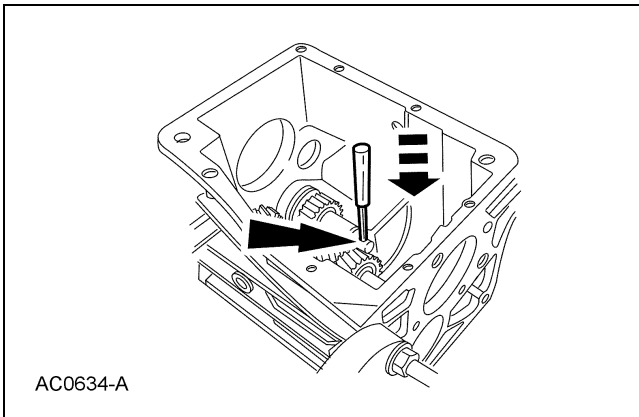

45. Inspect the rail bearing for wear or damage. Remove the bearing as necessary. Using a suitable puller, remove the rail bearing from the transmission. Discard the rail bearing.

46. Inspect the main shift rail bearings for wear or damage. Remove the bearings as necessary. Using a suitable puller, remove the main shift rail bearings from the extension housing. Discard the bearings.

43. Remove the reverse idler gear shaft, the reverse idler gear and bushing and the reverse gear overtravel stop.

DISASSEMBLY AND ASSEMBLY

Selector Plate

Disassembly

1. **NOTE:** Mark the position of each gear shifter fork.

Place the gear shift plates and the gear selector interlock sleeve in the NEUTRAL position to center the gear shift plates and the selector body.

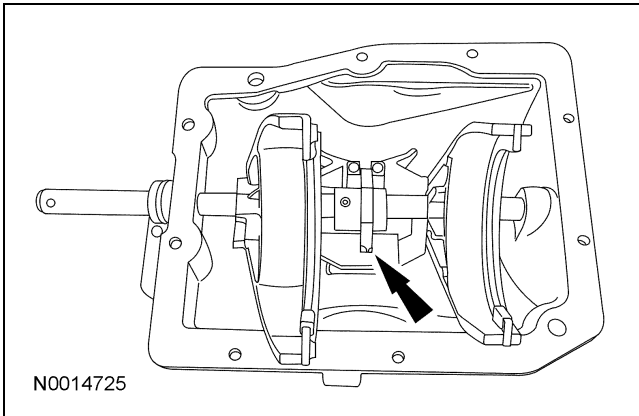

2. Rotate the main shift control shaft counterclockwise and pull it rearward to access the pin. Remove the roll pin and discard.

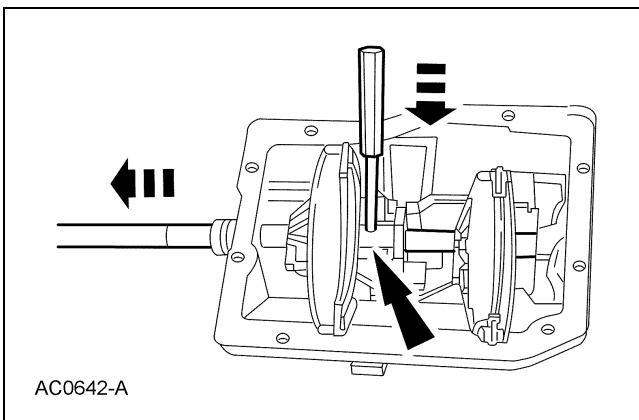

3. Using a twisting motion, remove the main shift control shaft.

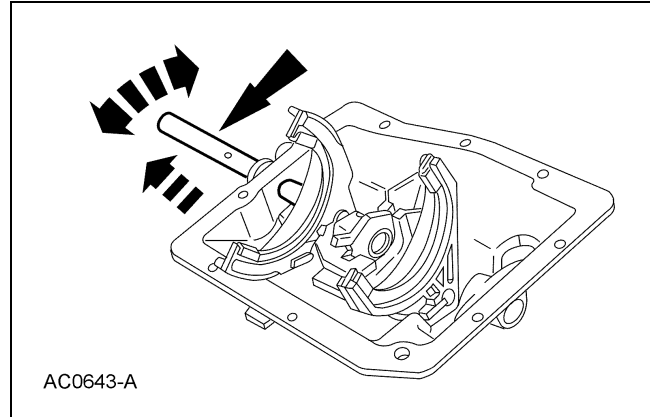

4. Remove the gear shifter forks, the gear shift plates, the pin, the gear selector interlock sleeve and the selector body.

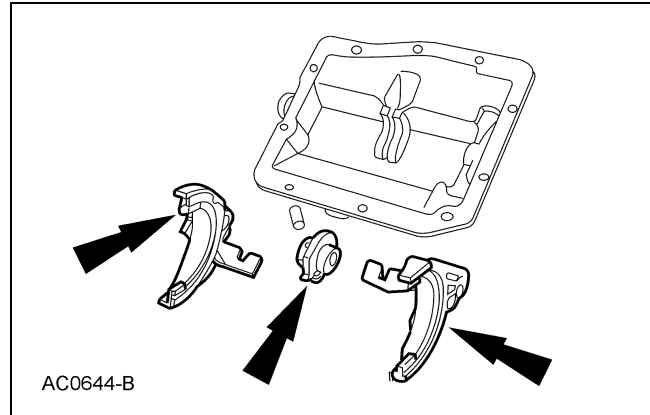

5. Remove and discard the O-ring.

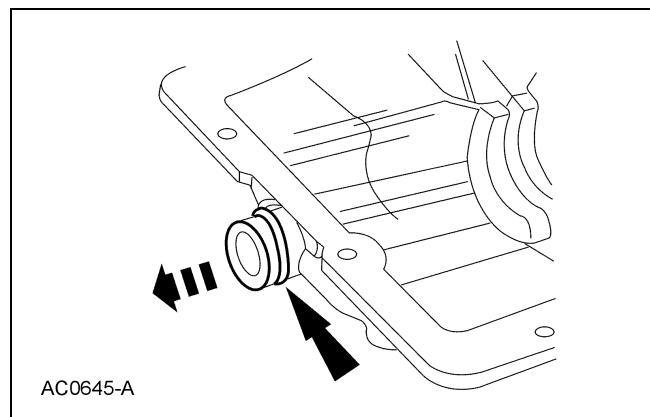

6. Inspect the main shift control shaft bushings for wear or damage. Remove the bushings as necessary. Using a suitable puller, remove the main shift control shaft bushings from the transmission case cover. Discard the bushings.

DISASSEMBLY AND ASSEMBLY (Continued)

7. **NOTE:** Note the orientation of the gear shift plate for assembly reference.
Remove the gear shift plate and the gear shift fork inserts from the shifter forks.

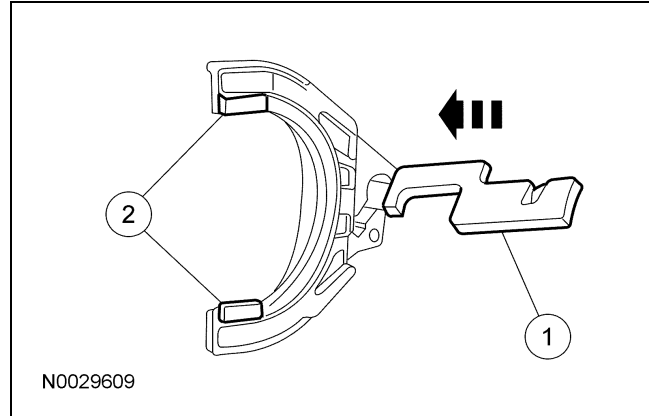
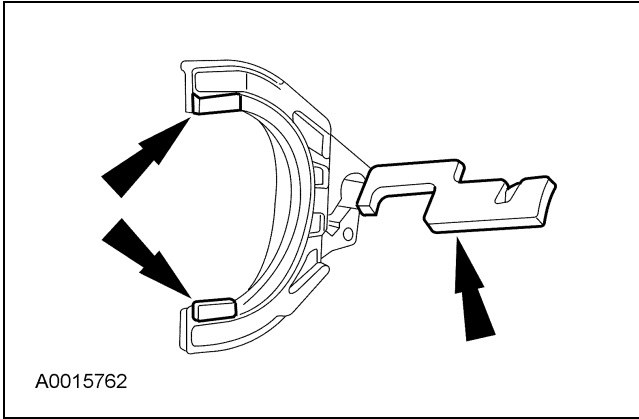

4. **NOTE:** Position the narrow side of the C-shaped gear selector interlock sleeve in the case cover slot. Position the roll pin hole in the selector body toward the rear of the cover.

Install the gear selector interlock sleeve and the selector body as an assembly.

Assembly

1. If removed, install new main shift control shaft bushings.
2. Install a new O-ring.

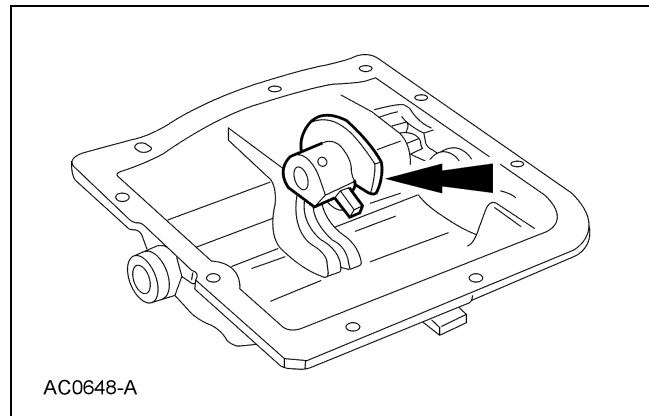
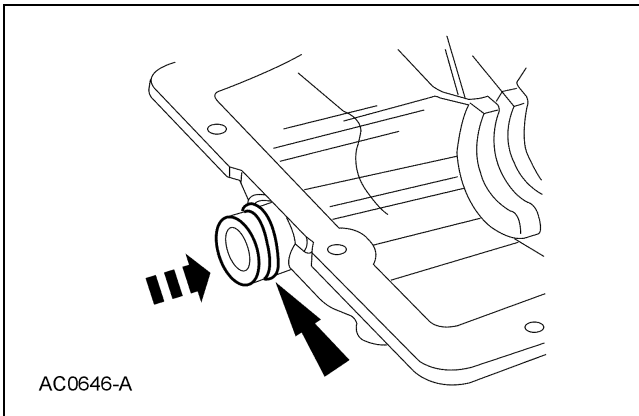

3. Assemble the gear shifter forks.
 1. Install the gear shift plate into the gear shifter fork.
 2. Install the gear shift fork inserts.

5. Lubricate the main shift control shaft with petroleum jelly.

DISASSEMBLY AND ASSEMBLY (Continued)

6. **NOTE:** The 1-2 gear shifter fork is the larger shifter fork. The gear shifter fork offset lever must face the cover. Position the gear shift plate attached to the 3-4 gear shifter fork under the gear shift plate attached to the 1-2 gear shifter fork.

Position the gear shifter forks and the main shift control shaft in the cover.

- Slide the shaft through the cover and shift the components until the shaft stops against the cover.

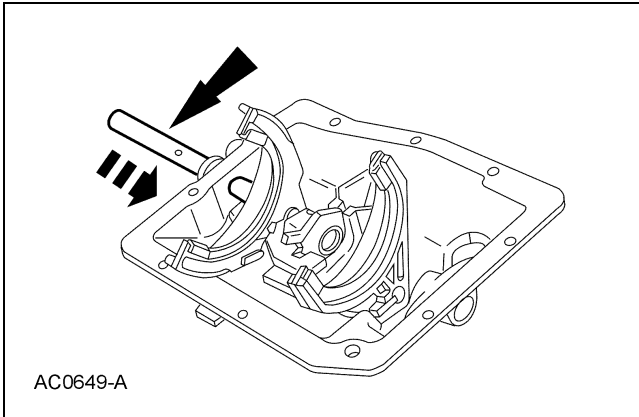

7. **NOTICE:** Install the pin slightly below the selector body surface. Failure to countersink the pin may result in interference between the pin and the gear selector interlock sleeve during shifts.

NOTE: The flat on the main shift control shaft must face upward.

Install the new roll pin.

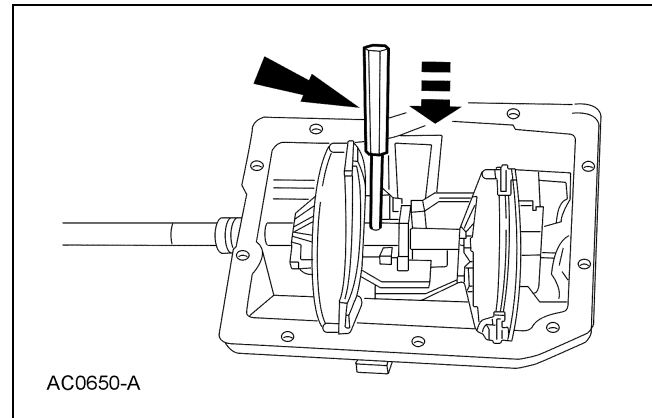

DISASSEMBLY AND ASSEMBLY

Input Shaft and Bearing

Special Tool(s)

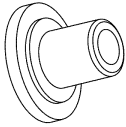
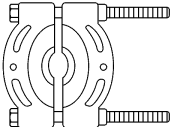
 <p>ST2355-A</p>	<p>Input Shaft Seal Replacer 308-220 (T94P-7025-AH)</p>
 <p>ST1895-A</p>	<p>Pinion Bearing Cone Remover 205-D002 (D79L-4621-A) or equivalent</p>

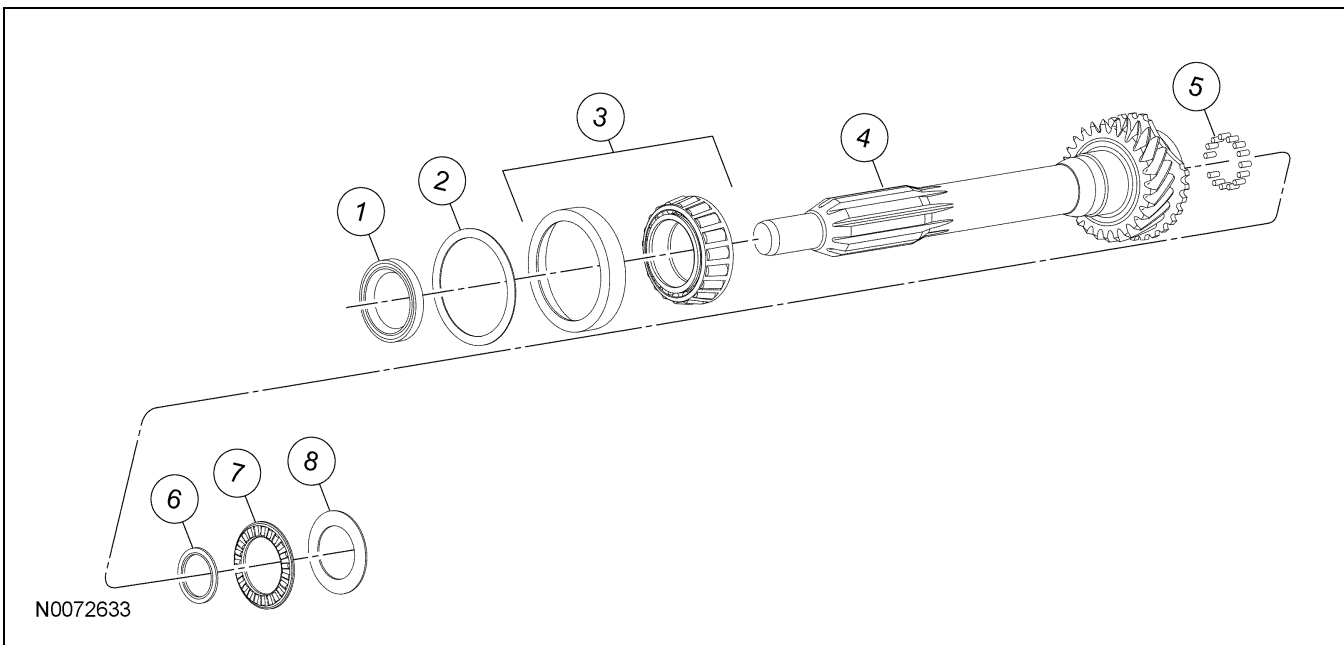

Item	Part Number	Description
1	7052	Input shaft seal
2	7L172	Shim
3	7025	Input shaft cup and bearing
4	7017	Input shaft

Item	Part Number	Description
5	7118	Roller bearing (15 required)
6	7L357	Input shaft bearing spacer
7	7D234	Input shaft thrust bearing
8	7D235	Input shaft thrust washer

(Continued)

DISASSEMBLY AND ASSEMBLY (Continued)**Disassembly**

- Using the Pinion Bearing Cone Remover and a press, remove the input shaft bearing.

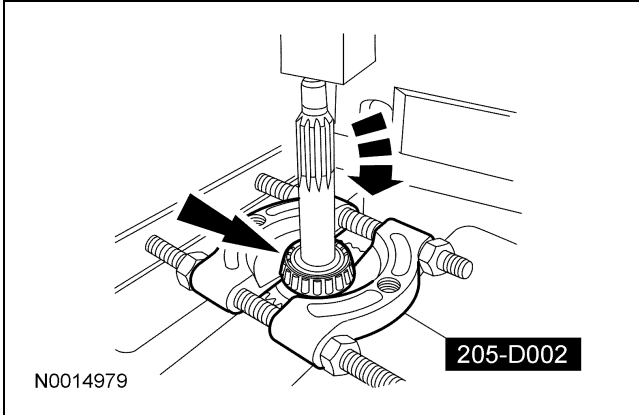

- Remove the input shaft bearing cup and the end play selective shims.

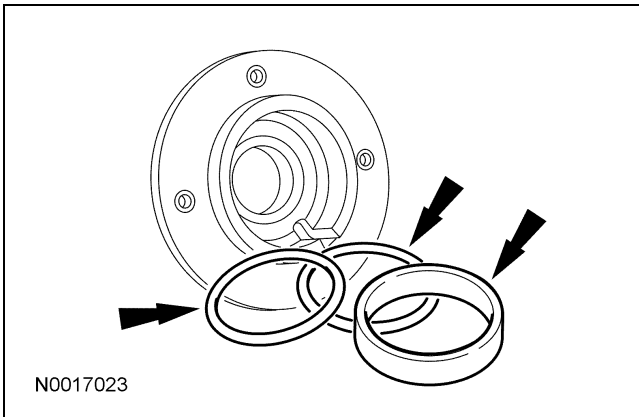

- Remove and discard the input shaft seal.
- Inspect the input shaft for damage or wear.
 - Inspect the surface of the input shaft in the area of the bearing race to make sure it is smooth and free of burrs.
 - Inspect the splines for nicks. Install a new input shaft as necessary.

Assembly

- Using the Input Shaft Seal Replacer, install a new input shaft seal.

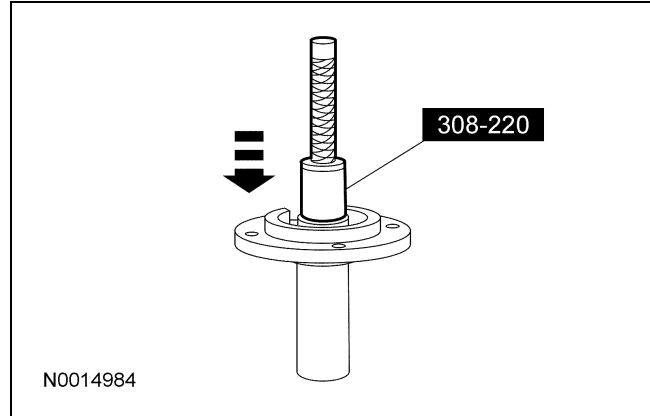

- NOTE:** Do not install the end play selective shims at this time.
Install the input shaft bearing cup.

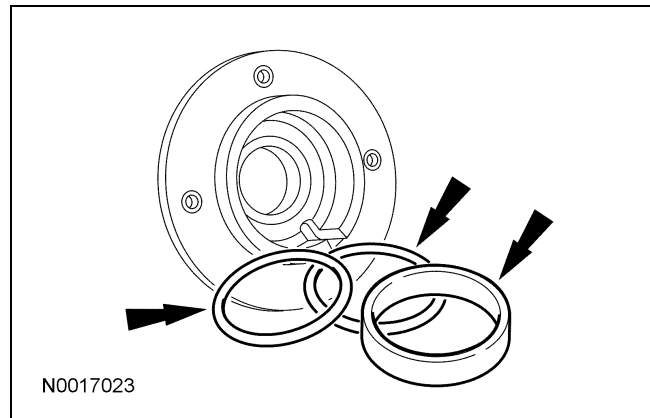

- Using a press and a capped length of pipe, install the input shaft bearing.

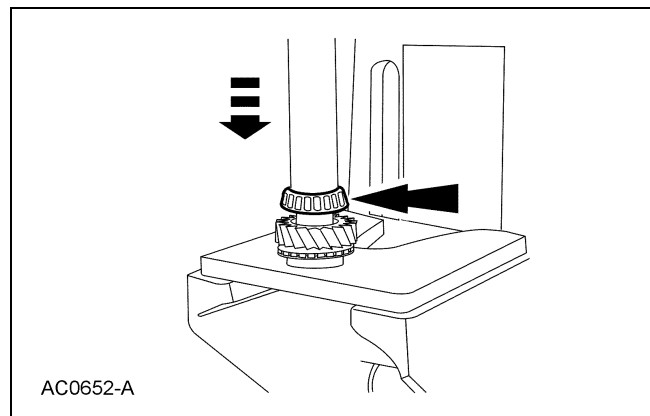

DISASSEMBLY AND ASSEMBLY

Output Shaft

Special Tool(s)

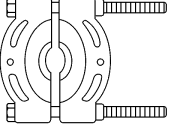
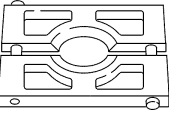
 <p>ST1895-A</p>	Pinion Bearing Cone Remove 205-D002 (D79L-4621-A) or equivalent
 <p>ST1310-A</p>	Remover, Bearing 205-055 (T71P-4621-B)

DISASSEMBLY AND ASSEMBLY (Continued)

Transmission Internal Components — Output Shaft Disassembled View

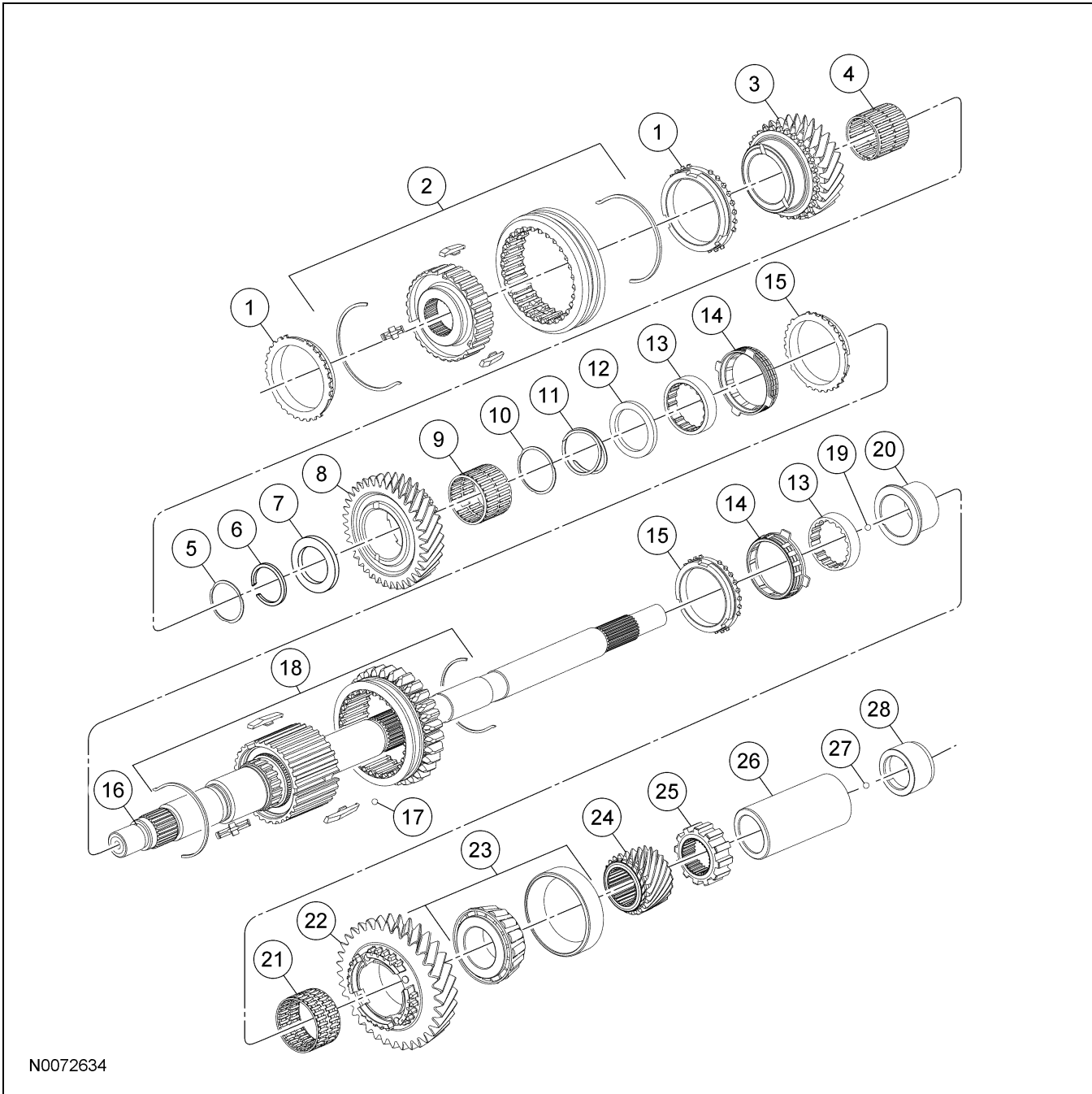

N0072634

Item	Part Number	Description
1	7107	3rd/4th gear synchronizer blocking rings
2	7124	3rd/4th gear synchronizer assembly
3	7B340	3rd gear
4	7B369	3rd gear needle bearing
5	7B320	3rd gear bearing spacer
6	7064	Snap ring
7	7119	Thrust washer

(Continued)

Item	Part Number	Description
8	7102	2nd gear
9	7B369	2nd gear needle bearing
10	7B320	2nd gear bearing spacer
11	7160	Main shaft bearing snap ring
12	7117	2nd gear synchronizer thrust washer
13	7175	1st/2nd gear synchronizer inner cones

(Continued)

DISASSEMBLY AND ASSEMBLY (Continued)

Item	Part Number	Description
14	7107	1st/2nd gear synchronizer intermediate cones
15	7107	1st/2nd gear synchronizer blocking rings
16	7061	Main shaft and synchronizer assembly
17	7K218	1st/2nd gear synchronizer check ball
18	7124	1st/2nd gear synchronizer assembly (serviced with 7061)
19	—	1st gear bearing spacer check ball
20	7173	1st gear bearing spacer
21	7127	1st gear needle bearing
22	7100	1st gear
23	7065	Main shaft rear bearing and cup
24	7K316	Main shaft 5th gear
25	7H373	Output Shaft Speed (OSS) sensor ring
26	7A021	Main shaft inner spacer
27	—	Main shaft outer spacer check ball
28	7065	Main shaft outer bearing and race assembly

Disassembly

1. **NOTICE:** Support the output shaft while using the press to prevent damage to the shaft or gears.

Using the Bearing Remover, press the Output Shaft Speed (OSS) sensor ring from the output shaft.

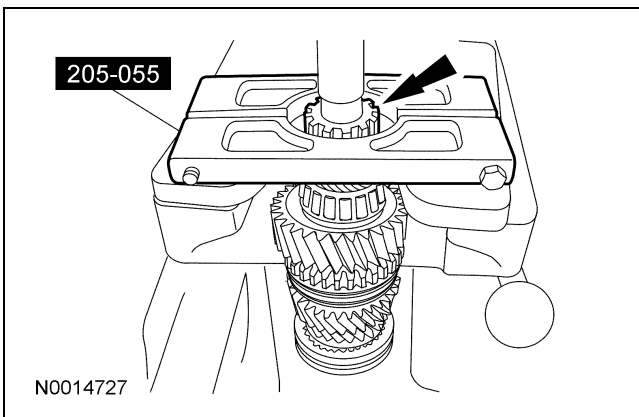

2. Using the Pinion Bearing Cone Remover, press 1st gear, the output shaft rear bearing and the 5th speed driven gear from the output shaft as an assembly.

- Discard the output shaft rear bearing.
- Inspect the gears for wear or damage. Install new gears as necessary.

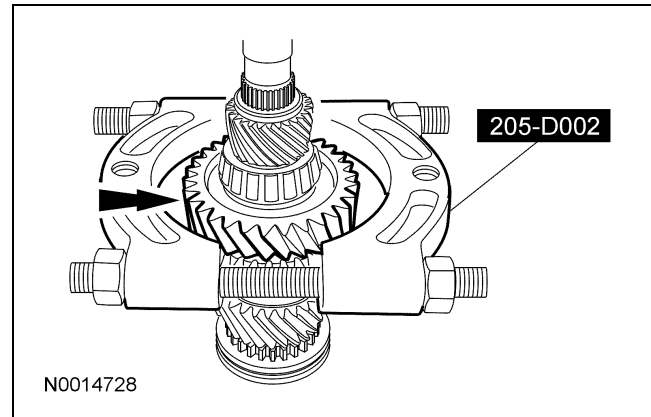

3. Remove 1st gear needle bearing.

- Inspect the needle bearing for wear or damage. Install a new bearing as necessary.

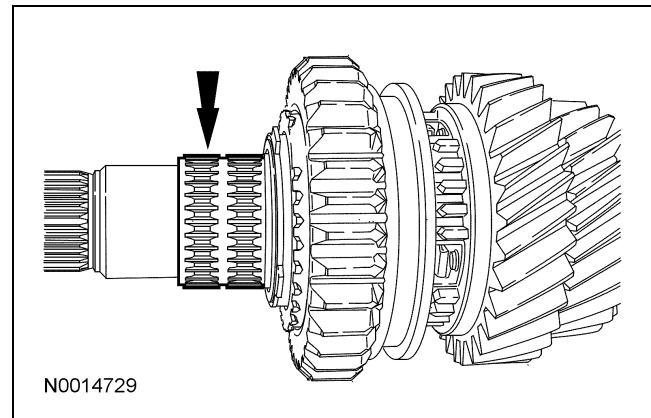

DISASSEMBLY AND ASSEMBLY (Continued)

4. **NOTE:** The 1st gear bearing spacer fits snugly on the output shaft.

Remove the 1st gear bearing spacer.

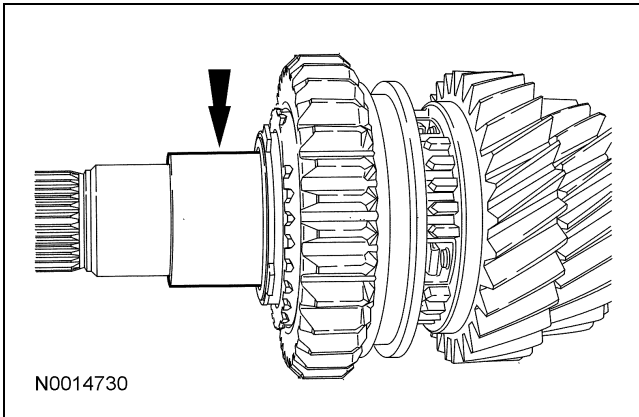

5. Remove the 1st and 2nd speed synchronizer hub ball.

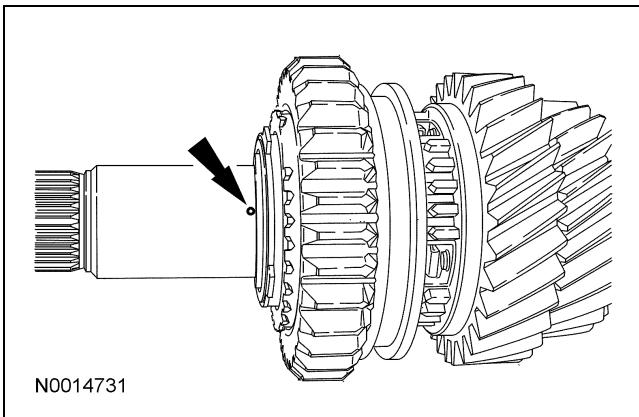

6. Remove the 1st gear synchronizer inner cone, 1st gear synchronizer outer cone and the 1st gear synchronizer blocking ring.

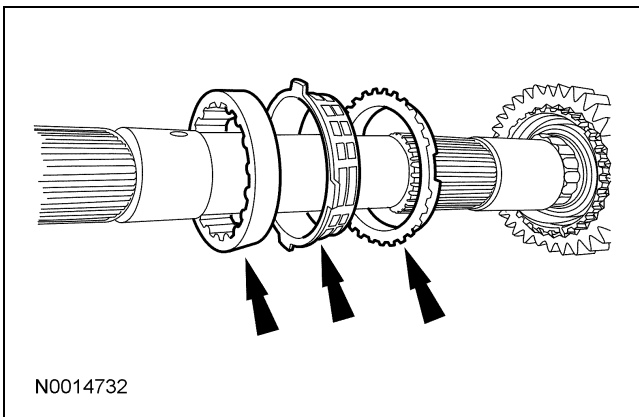

7. **NOTE:** Reposition the output shaft on the press with the input shaft end facing upward.

Using a suitable tool, press the 3rd and 4th gear synchronizer assembly, the 3rd gear blocking ring and 3rd gear from the output shaft as an assembly.

- Inspect the gear for wear or damage. Install a new gear as necessary.
8. Disassemble and inspect the 3rd and 4th gear synchronizer assembly. For additional information, refer to Synchronizers in this section.
9. Remove 3rd gear needle bearing.
- Inspect the needle bearing for wear or damage. Install a new bearing as necessary.

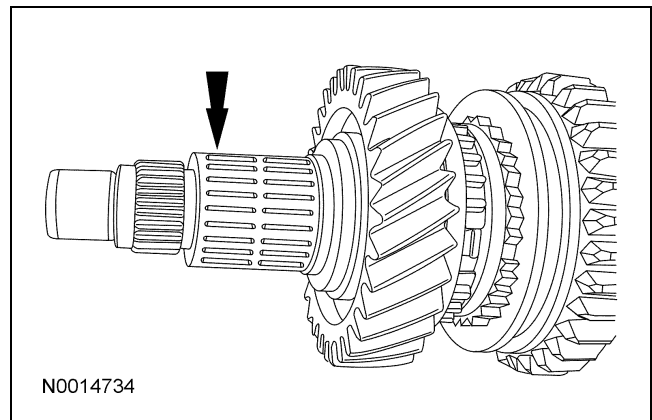

10. Remove the snap ring and discard.

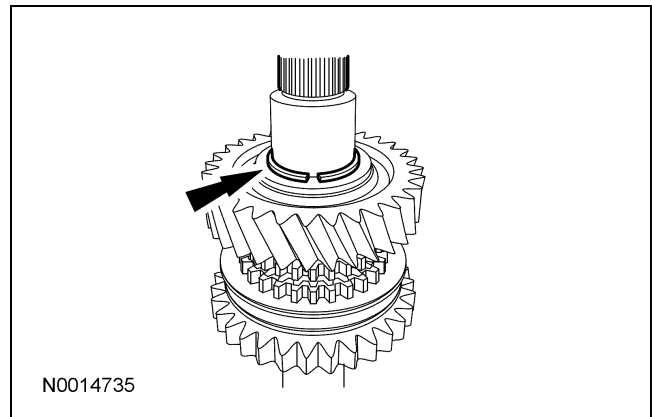

DISASSEMBLY AND ASSEMBLY (Continued)

11. Remove the 2nd gear bearing spacer.

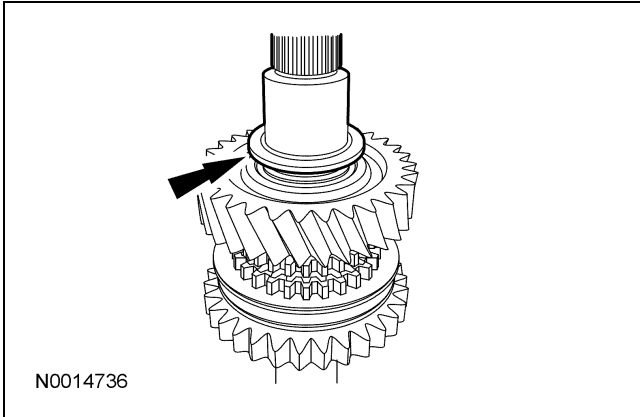

12. Remove 2nd gear.

- Inspect the gear for wear or damage. Install a new gear as necessary.

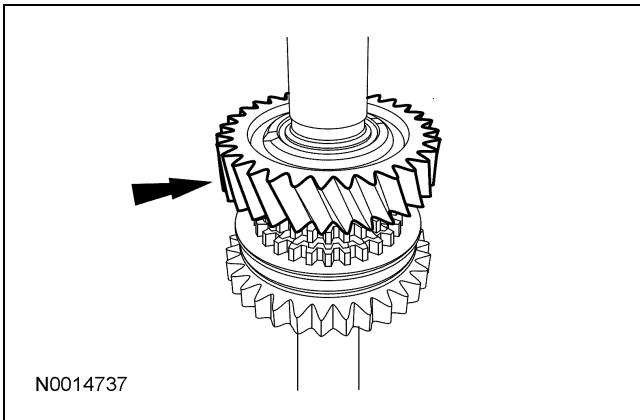

13. Remove 2nd gear needle bearing.

- Inspect the needle bearing for wear or damage. Install a new bearing as necessary.

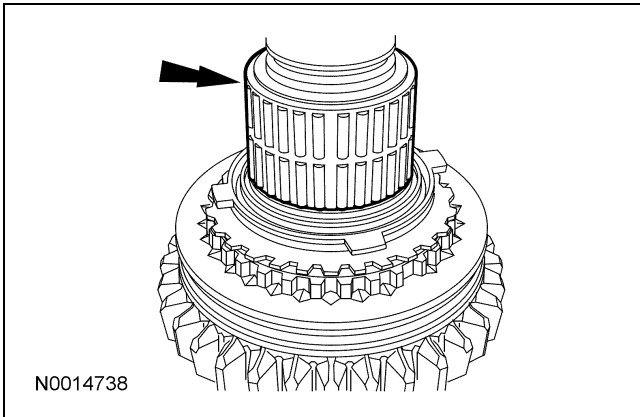

14. Remove the output shaft bearing snap ring and discard.

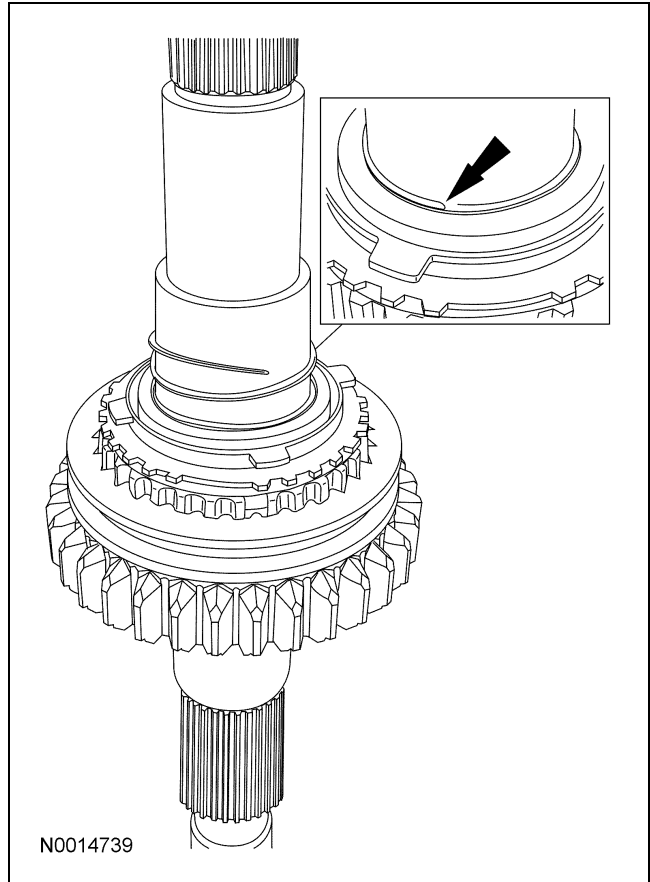

15. Remove the 2nd gear synchronizer thrust washer.

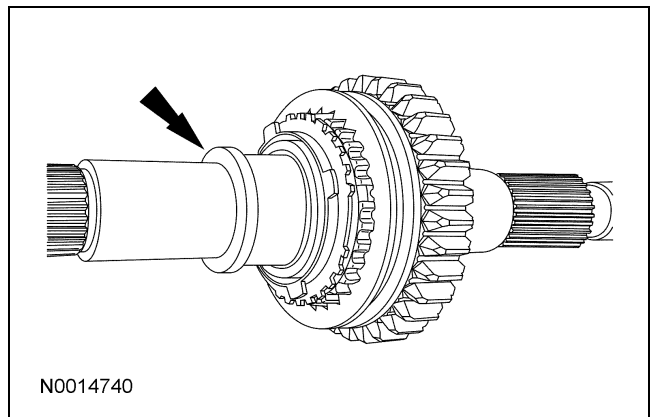

DISASSEMBLY AND ASSEMBLY (Continued)

16. Remove the 2nd gear synchronizer inner cone, the 2nd gear synchronizer outer cone and the 2nd gear synchronizer blocking ring as an assembly.

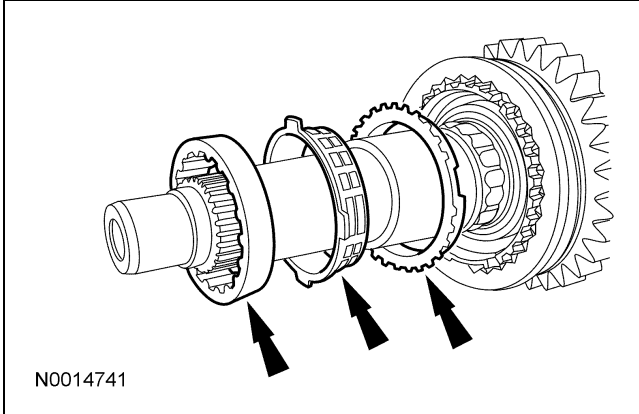

17. **NOTE:** The 1st and 2nd gear synchronizer sliding sleeve, the hub and the output shaft are an assembly. Do not attempt to separate the hub from the output shaft. Only the synchronizer hub insert springs and the synchronizer hub inserts are available separately.

Remove the 1st and 2nd gear synchronizer sliding sleeve. Disassemble and inspect the 1st and 2nd gear synchronizer assembly. For additional information, refer to Synchronizers in this section.

Assembly

1. Lubricate all components with transmission fluid during assembly. Soak the blocking rings in transmission fluid for 10 minutes.
2. Install the 1st and 2nd gear synchronizer hub insert springs and the synchronizer inserts into the synchronizer hub. Install the sliding sleeve onto the hub.
3. **NOTE:** Align the slots in the synchronizer blocking ring with the tabs in the 1st and 2nd gear synchronizer.

Install the 2nd gear synchronizer blocking ring, the 2nd gear synchronizer outer cone and the 2nd gear synchronizer inner cone.

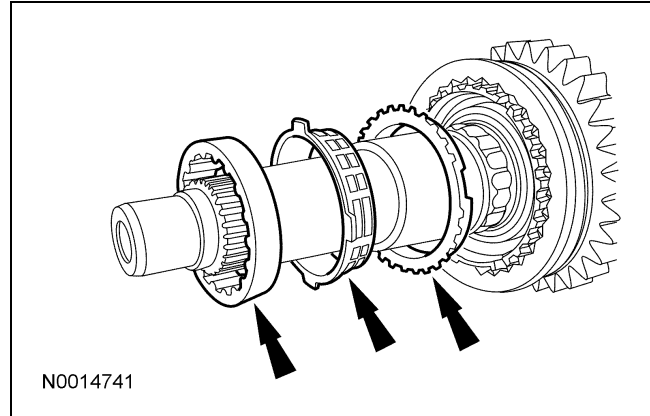

4. Install the 2nd gear synchronizer thrust washer.

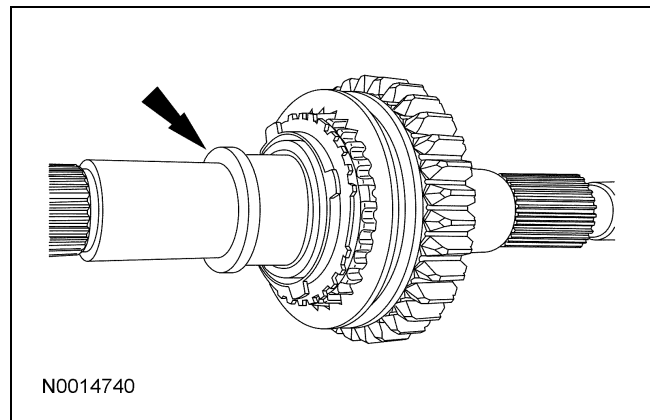

5. Install the new output shaft bearing snap ring.

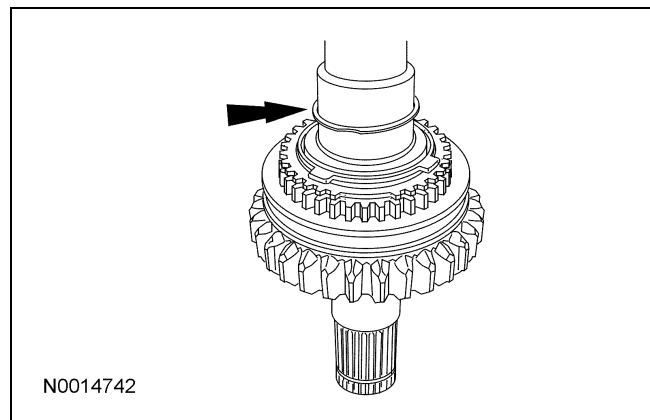

DISASSEMBLY AND ASSEMBLY (Continued)

6. Install the 2nd gear needle bearing.

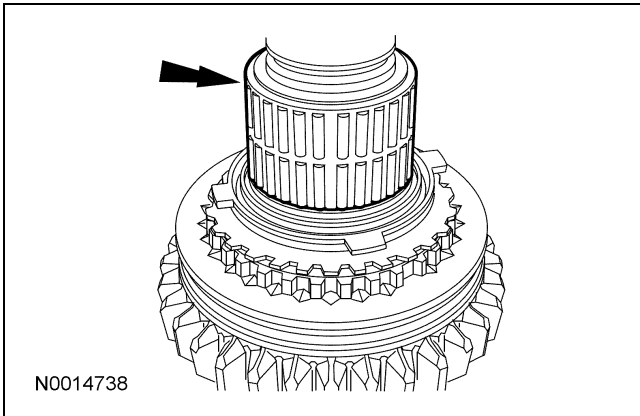

8. Install the 2nd gear bearing spacer.

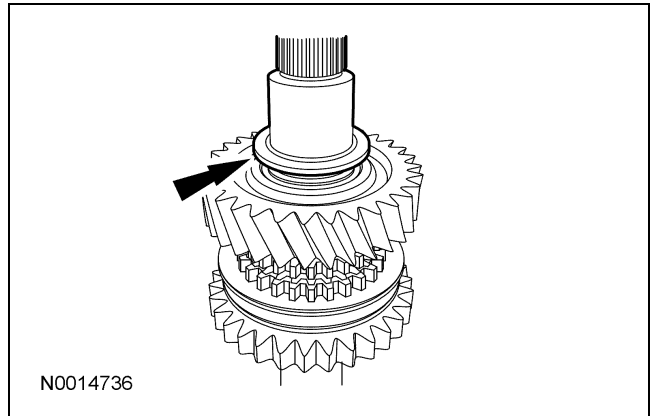

7. Align the slots on 2nd gear with the tabs on the synchronizer blocking ring. Install 2nd gear.

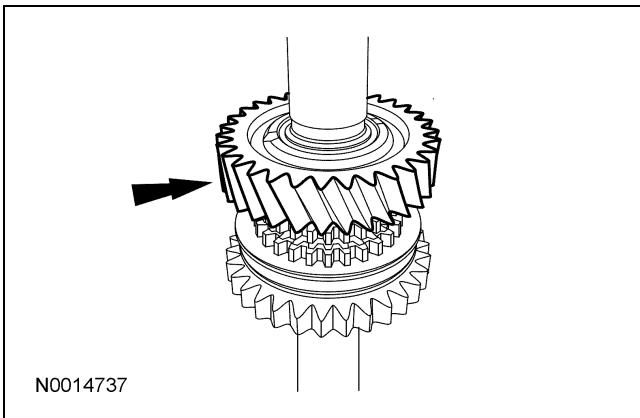

9. Install a new snap ring.

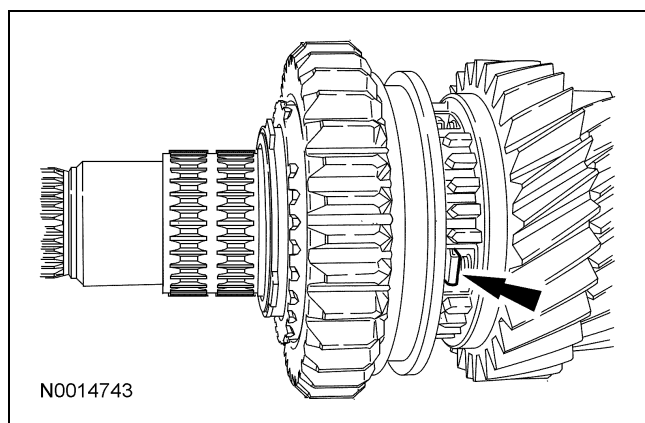
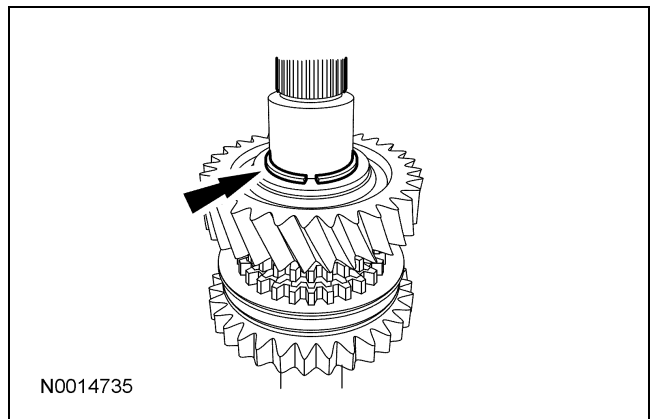

10. Install 3rd gear needle bearing.

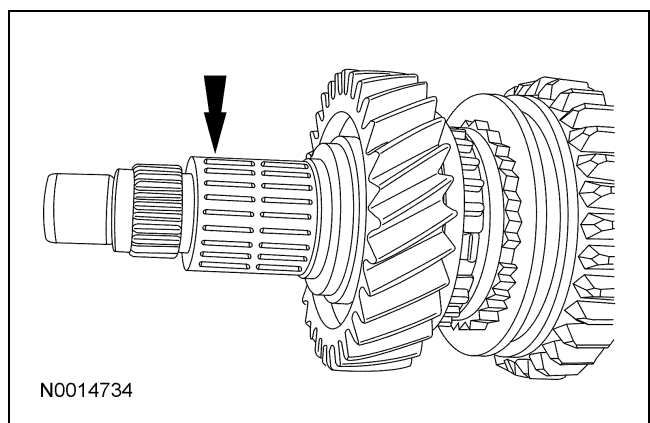

DISASSEMBLY AND ASSEMBLY (Continued)

11. **NOTE:** Align the slots on 3rd gear with the tabs on the synchronizer blocking ring.
Position 3rd gear, the 3rd gear synchronizer blocking ring and the 3rd and 4th gear synchronizer assembly on the output shaft.

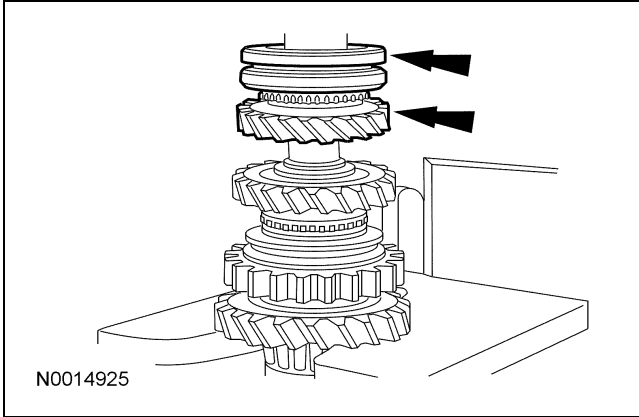

12. **NOTE:** Before pressing the components together, verify that the synchronizer hub faces the short end of the output shaft. Hold 3rd gear against the synchronizer to maintain the synchronizer blocking ring alignment.
Using a 1-1/2-inch deep well socket, press the 3rd gear, the 3rd gear synchronizer blocking ring and the 3rd and 4th gear synchronizer assembly onto the output shaft.

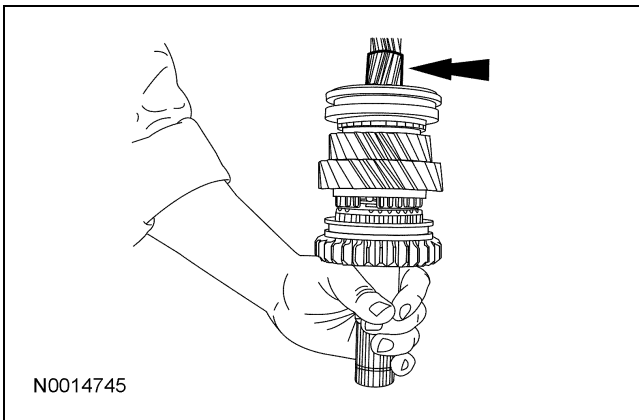

13. **NOTE:** Reposition the output shaft on the press with the output end facing upward.
Install the 1st gear synchronizer blocking ring, the 1st gear synchronizer outer cone and the 1st gear synchronizer inner cone.

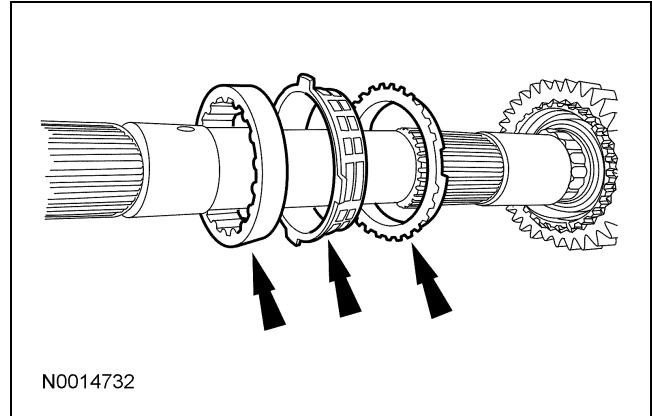

14. Install the 1st and 2nd gear synchronizer hub ball.

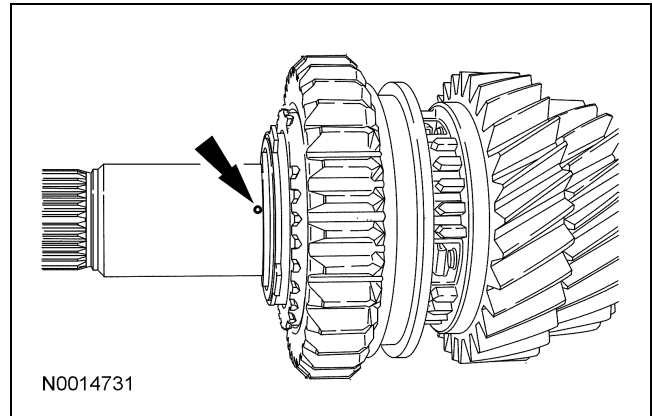

15. **NOTE:** The 1st gear bearing spacer fits snugly on the output shaft.
Align the notch in the 1st gear bearing spacer and the 1st and 2nd gear synchronizer hub ball.
Install the 1st gear bearing spacer.

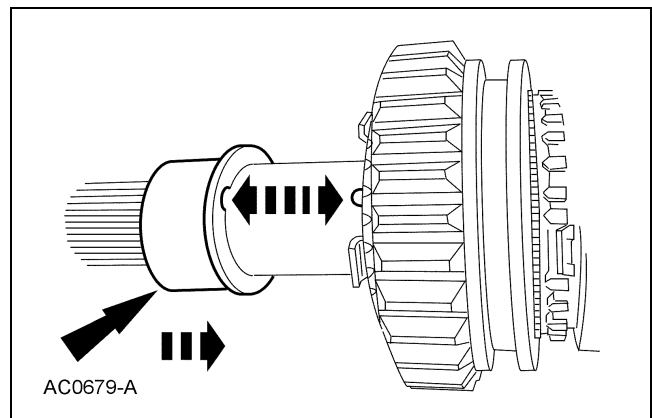

DISASSEMBLY AND ASSEMBLY (Continued)

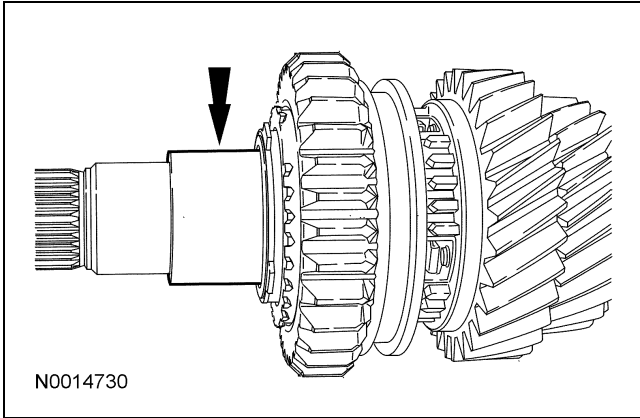

16. Install the 1st gear needle bearing.

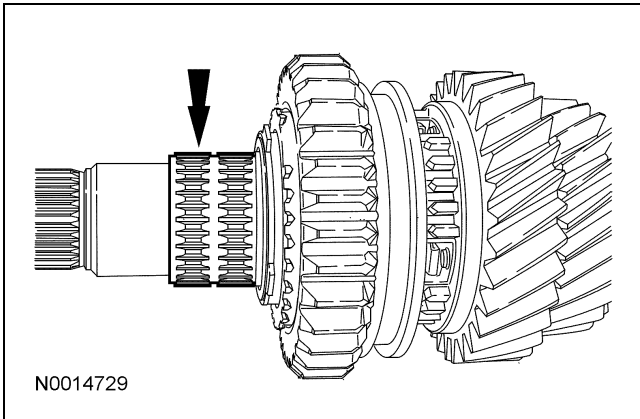

17. Align the slots on the synchronizer blocking ring and the slots on the 1st gear. Install 1st gear.

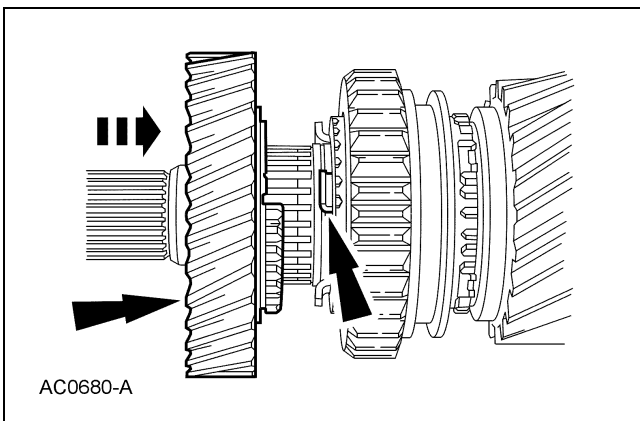

18. Install the output shaft rear bearing.

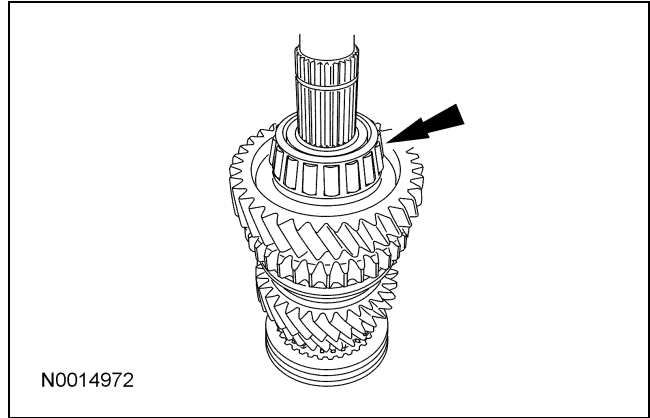

19. **NOTICE:** Align the output shaft splines and the splines of the 5th speed driven gear or damage will occur.

Lubricate the splines of the 5th speed driven gear with petroleum jelly. Position the 5th speed driven gear on the output shaft. Using a capped length of pipe 31.7 mm (1.24 in) inside diameter by 356 mm (14.01 in) long, press on the 5th speed driven gear.

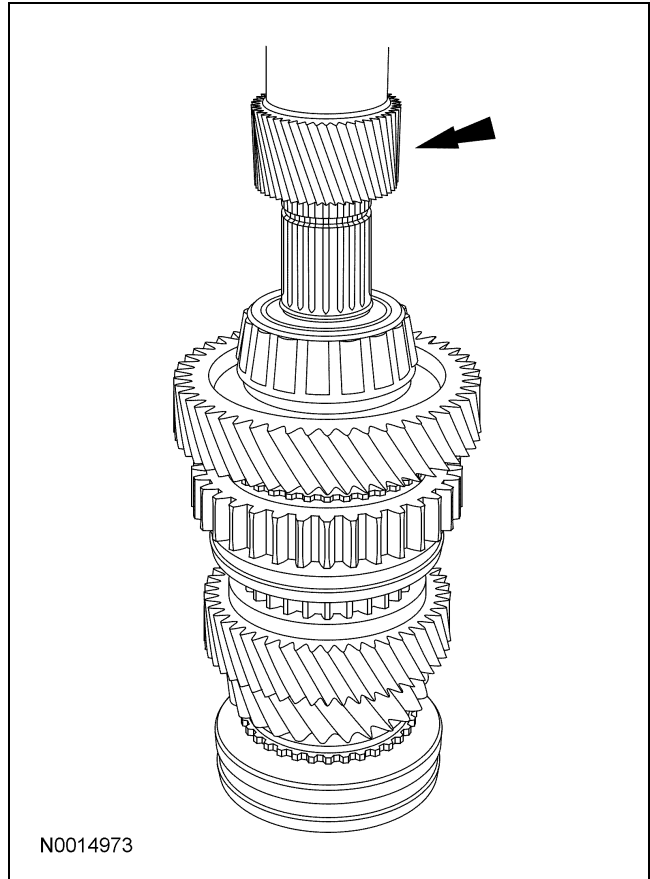

DISASSEMBLY AND ASSEMBLY (Continued)

20. Using the capped length of pipe 31.7 mm (1.24 in) inside diameter by 356 mm (14.01 in) long, press the OSS sensor ring on the output shaft.

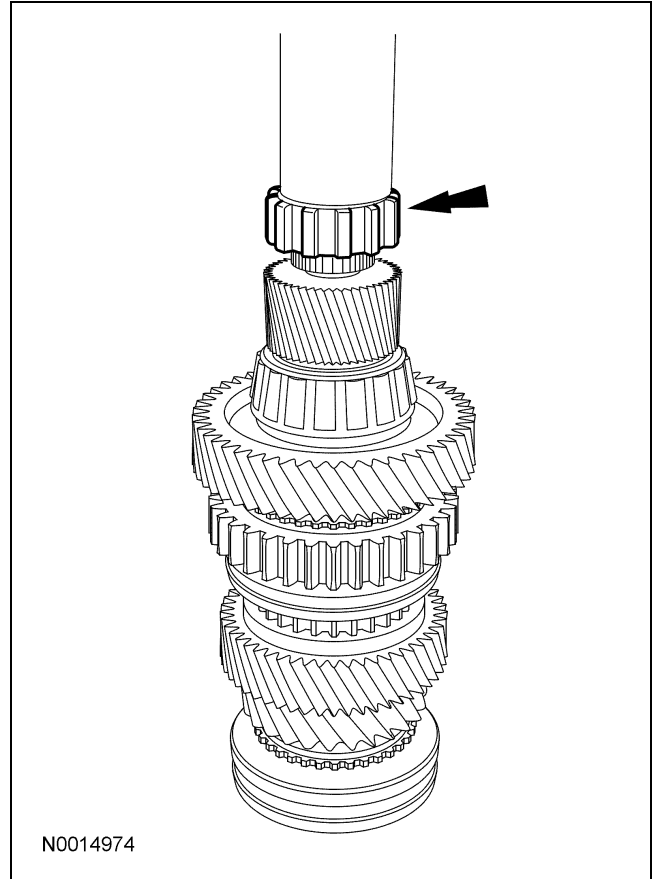

DISASSEMBLY AND ASSEMBLY

Countershaft Bearing

Special Tool(s)

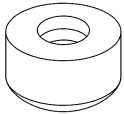
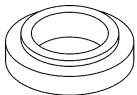
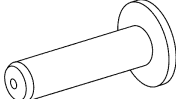
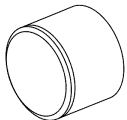
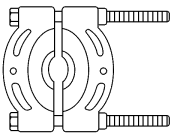
 <p>ST2356-A</p>	<p>Installer, Bearing 308-061 (T77J-7025-L)</p>
 <p>ST2359-A</p>	<p>Installer, Drive Pinion Bearing Cone 205-011 (T57L-4621-B)</p>
 <p>ST2358-A</p>	<p>Installer, Input Shaft Bearing 308-062 (T77J-7025-M)</p>
 <p>ST2357-A</p>	<p>Installer, Mainshaft Front Bearing 308-081 (T82T-7003-DH)</p>
 <p>ST1895-A</p>	<p>Remover, Drive Pinion Bearing Cone 205-D002 (D79L-4621-A) or equivalent</p>

(Continued)

Special Tool(s)

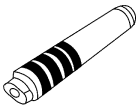
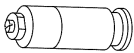
 <p>ST1303-A</p>	<p>Remover/Installer, Bearing Tube 308-024 (T75L-7025-B)</p>
 <p>ST2147-A</p>	<p>Remover/Installer, Bearing Tube 308-052 (T77J-7025-B)</p>

Material

Item	Specification
Threadlock and Sealer TA-25	WSK-M2G351-A5

DISASSEMBLY AND ASSEMBLY (Continued)

Transmission Internal Components — Countershaft Disassembled View

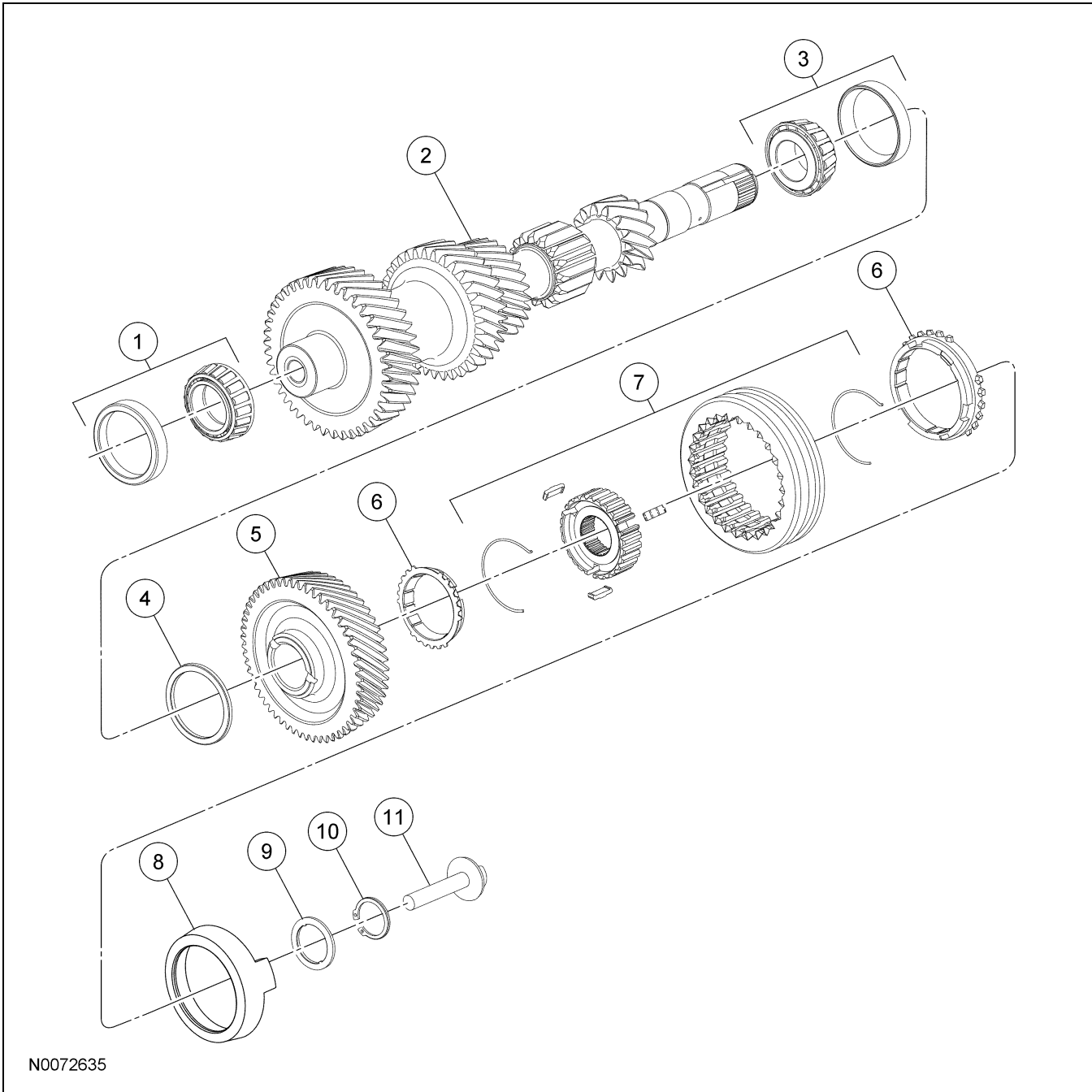

N0072635

Item	Part Number	Description
1	7F431	Countershaft front bearing and cup
2	7113	Countershaft
3	7F431	Countershaft rear bearing and cup
4	7L172	Countershaft rear bearing adjustment shim
5	7144	Countershaft 5th gear

(Continued)

Item	Part Number	Description
6	7107	5th gear synchronizer blocking rings
7	7124	5th gear synchronizer assembly
8	7M000	Reverse brake ring
9	7G042	Thrust washer
10	7059	5th gear synchronizer retaining ring
11	7L276	Oil pick up funnel

DISASSEMBLY AND ASSEMBLY (Continued)

Disassembly

- Using the Drive Pinion Bearing Cone Remover, press and remove the countershaft bearing from the countershaft.

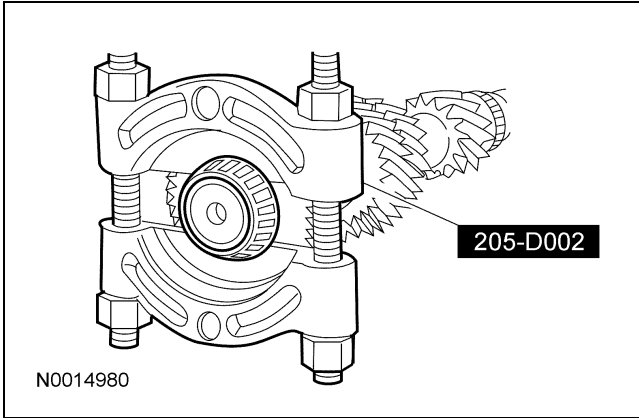

- NOTICE: Failure to correctly support the case during bearing race removal will result in permanent distortion of the case.**

NOTE: Remove the front countershaft bearing cup if damaged, worn or a new countershaft bearing is being installed.

Using the Bearing Tube Remover/Installer, Input Shaft Bearing Installer, Mainshaft Front Bearing Installer and the Bearing Installer, press and remove the bearing cup and the countershaft front bearing seal from the case.

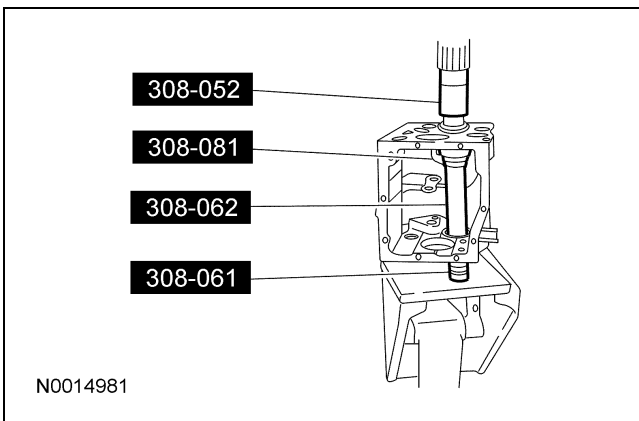

Assembly

NOTE: Position the countershaft in the transmission case before installing the rear countershaft bearing.

- Install the countershaft front bearing seal on the bearing cup.

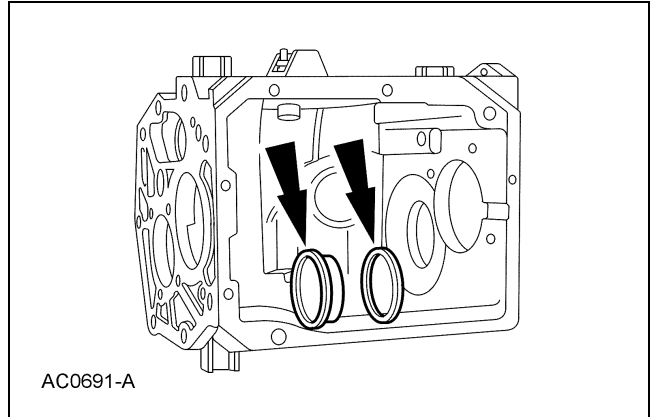

- Coat the outside diameter of the bearing cup with threadlock.

- NOTICE: Failure to correctly support the case during bearing race installation will result in permanent distortion of the case.**

Using the Bearing Tube Remover/Installer and Drive Pinion Bearing Cone Installer and a press, install the bearing cup.

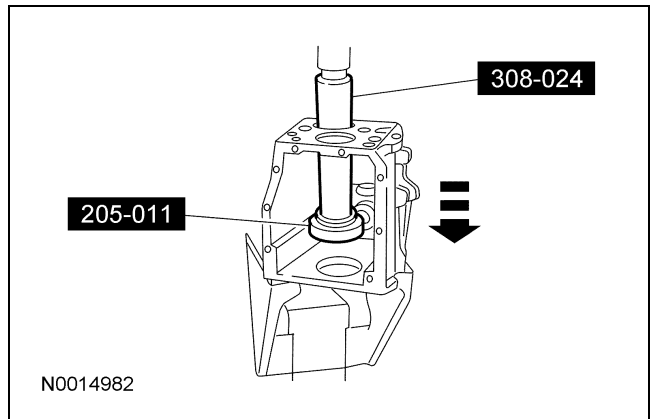

DISASSEMBLY AND ASSEMBLY (Continued)

- 4. Using the Drive Pinion Bearing Cone Installer and a press, install the front countershaft bearing.

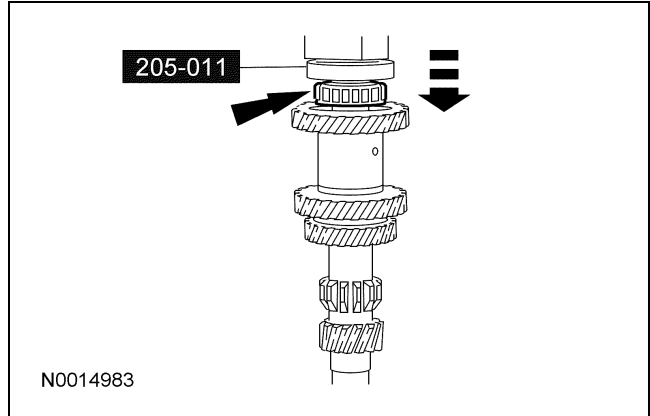

DISASSEMBLY AND ASSEMBLY

Synchronizers

Disassembly

NOTE: This procedure applies to all synchronizer assemblies.

1. **NOTE:** Synchronizer components are not interchangeable. During disassembly, mark each individual synchronizer for assembly. Synchronizer hubs and sleeves are a selected assembly and should be kept together as originally assembled. Blocking rings are not interchangeable, do not mix.
Scribe an alignment mark on the sliding sleeve and the hub for assembly reference.
2. Using a screwdriver, remove the spring. Turn the synchronizer over and remove the 2nd spring. Remove the sliding sleeve and the synchronizer struts from the hub.

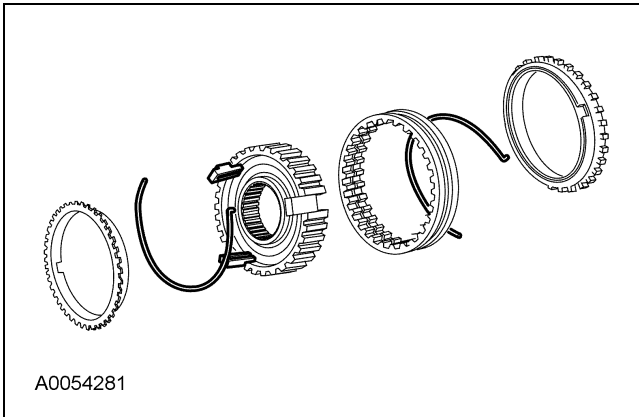

4. Inspect the synchronizer blocking rings.
 - Check for wear or damage. Install new synchronizer blocking rings as necessary.
 - Check the clearance between the synchronizer blocking ring and the gear.
 - Position the blocking ring onto the gear. Make sure the correct blocking ring is measured with the correct gear and that the blocking ring is fully seated on the gear.
 - Insert a feeler gauge and measure the clearance, while applying pressure and rotating the blocking ring. The measurement should be the same around the entire circumference. If the clearance is less than 0.38 mm (0.015 in), install new blocking rings.

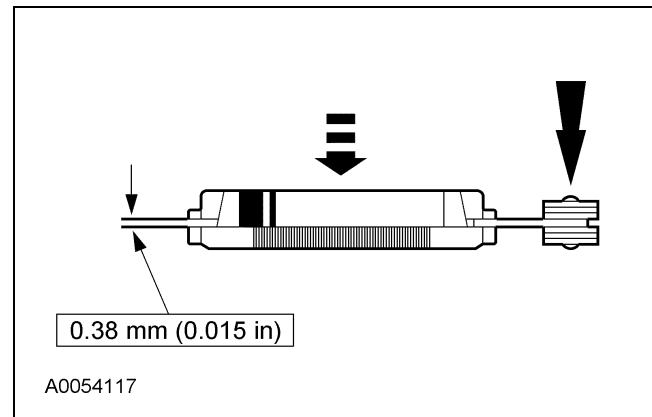

3. Inspect the synchronizer components.
 - Check for worn, nicked or broken teeth. Install a new synchronizer as necessary.
 - Check keys for wear or distortion. Install a new synchronizer as necessary.
 - Check springs for distortion. Install a new synchronizer as necessary.

DISASSEMBLY AND ASSEMBLY (Continued)**Assembly**

1. **NOTICE:** Match the alignment marks make during disassembly. The sleeve and the hub have an extremely close fit. Hold the sleeve and hub square to prevent jamming. Do not force the sleeve onto the hub.

Assemble the synchronizer as follows:

- Position the synchronizer sleeve on the hub. Make sure to align key openings in the hub with the synchronizer sleeve.
 - Install the keys with the slots facing the hub.
 - Install the spring. Locate the tang to one of the key slots and position into place. Install the second spring. Locate the spring tang on the same key but position in the opposite direction.
-

DISASSEMBLY AND ASSEMBLY

Transmission

Special Tool(s)

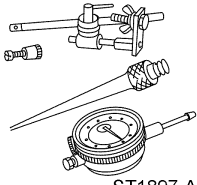
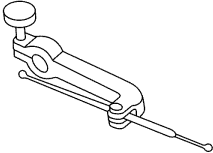
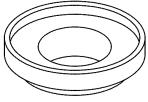
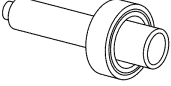
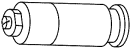
 <p>ST1897-A</p>	<p>Dial Indicator Gauge with Holding Fixture 100-002 (TOOL-4201-C) or equivalent</p>
 <p>ST1348-A</p>	<p>Gauge, Clutch Housing 308-021 (T75L-4201-A)</p>
 <p>ST2360-A</p>	<p>Installer, Torrington Bearing 308-083 (T83P-7025-AH)</p>
 <p>ST2199-A</p>	<p>Installer, Transmission Extension Housing Oil Seal 308-227 (T94P-7657-A)</p>
 <p>ST2147-A</p>	<p>Remover/Installer, Bearing Tube 308-052 (T77J-7025-B)</p>

Material

Item	Specification
Multi-Purpose Grease XG-4 and/or XL-5	ESB-M1C93-B
Premium Long-Life Grease XG-1-C or XG-1-K (US); CXG-1-C (Canada)	ESA-M1C75-B
Thread Sealant with PTFE TA-24	WSK-M2G350-A2

Material

Item	Specification
Clear Silicone Rubber TA-32	ESB-M4G92-A
MERCON® V Automatic Transmission Fluid XT-5-QM (or XT-5-QMC) (US); CXT-5-LM12 (Canada)	MERCON® V

(Continued)

DISASSEMBLY AND ASSEMBLY (Continued)

Transmission Case and Shift Components — Disassembled View

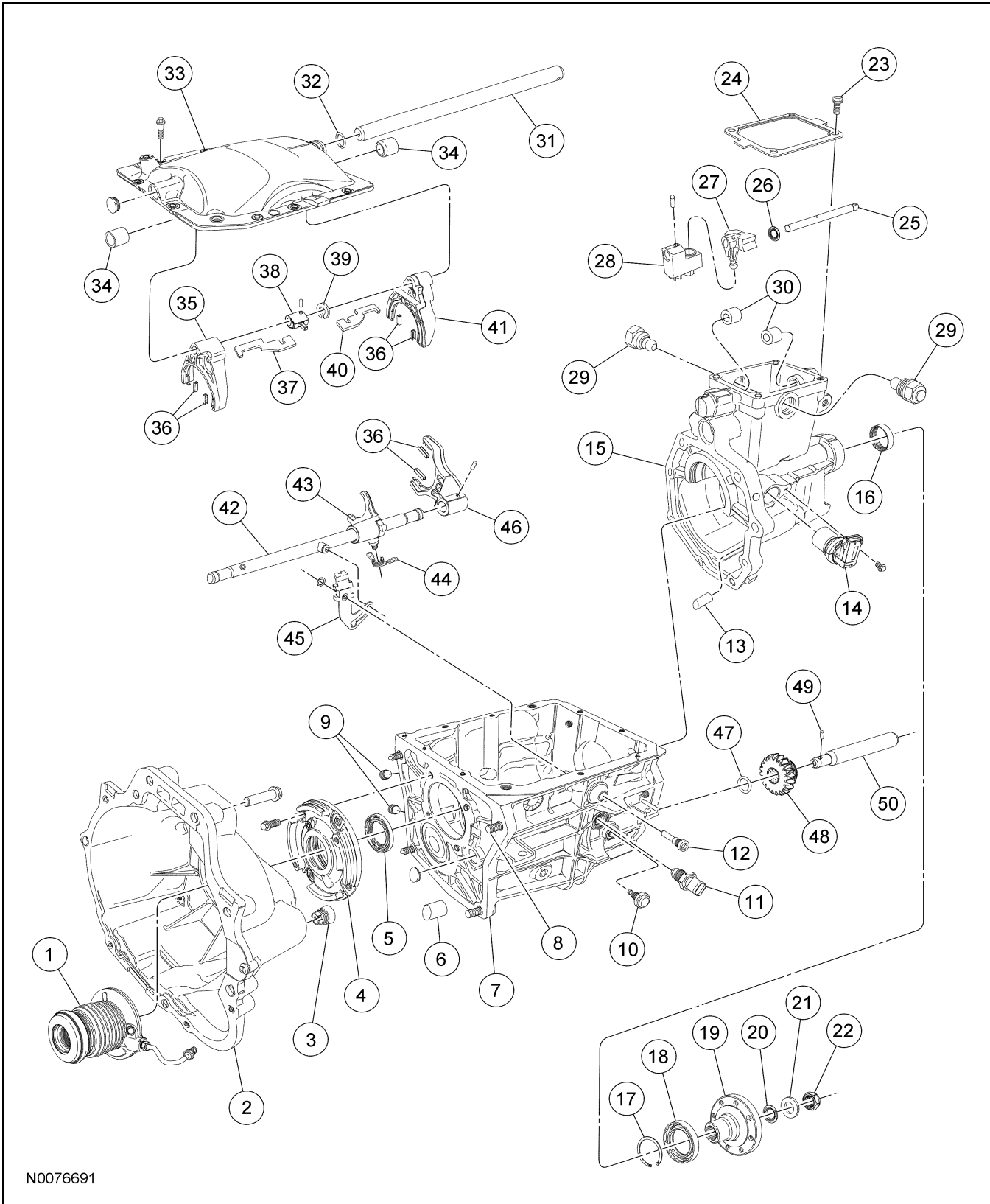

N0076691

DISASSEMBLY AND ASSEMBLY (Continued)

Item	Part Number	Description
1	7A508	Slave cylinder and release bearing
2	7500	Clutch housing
3	7K584	Slave cylinder line retainer
4	7050	Input shaft bearing retainer
5	7052	Input shaft seal
6	7W425	Shaft bearing
7	7005	Main case
8	7A443	Main case-to-clutch housing bolt
9	87675-S	Drain and fill plugs
10	7K024	Reverse lever pivot bolt
11	15520	Reverse lamp switch
12	7K024	Shift lever reverse pin
13	7W425	Shaft bearing
14	7H103	Output Shaft Speed (OSS) sensor
15	7A039	Extension housing
16	7065	Extension housing bearing
17	7109	Extension housing bearing snap ring
18	7052	Output shaft seal
19	7K359	Transmission flange
20	7E397	Flange seal
21	7119	Thrust washer
22	7K440	Output flange nut
23	7A443	Gear shift cover bolt
24	7222	Gear shift cover
25	7240	Shift rail selector
26	7052	Selector rail seal
27	7N094	Selector finger
28	7F018	Gearshift offset lever
29	7234	Shifter detents
30	7127	Main shift rail bearings
31	7358	Main shift control shaft
32	87038-S91	Main shift rail seal
33	7222	Transmission case cover
34	7W425	Main shift control shaft bushings
35	7230	3rd/4th gear shift fork

(Continued)

Item	Part Number	Description
36	7L082	Shift fork inserts
37	7N232	Gear shift plate
38	7302	Selector body
39	7K201	Gear selector interlock sleeve
40	7N232	Gear shift plate
41	7230	1st/2nd gear shift fork
42	7240	Reverse gear shift rail
43	7230	Reverse shift fork
44	7E485	Reverse shift fork spring
45	7K002	Reverse gearshift lever
46	7230	5th gear shift fork
47	7E397	Reverse gear overtravel stop
48	7141	Reverse idler gear and bushing
49	357479-S15	Pin
50	7140	Reverse idler gear shaft

- NOTE:** Soak the blocking rings in transmission fluid for 10 minutes.
Lubricate all components with transmission fluid during assembly.
- If removed, install new rail bearings into the transmission case.
- If removed, install new main shift rail bearings into the extension housing.
- Position the countershaft cluster gear in the case.

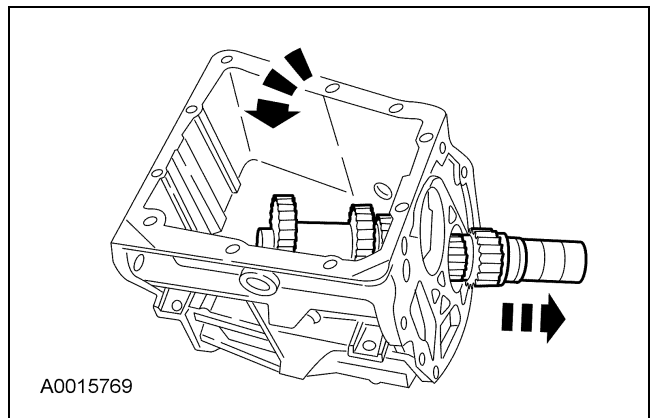

DISASSEMBLY AND ASSEMBLY (Continued)

5. **NOTICE:** Failure to correctly support the case during bearing installation will result in permanent distortion of the case.

Using the Bearing Tube Remover/Installer and Torrington Bearing Installer and a press, install the rear countershaft bearing assembly.

- 1 Position two 6.35 mm (0.25 in) pieces of bar stock between the countershaft and the case.
- 2 Press the rear countershaft bearing assembly in the case.

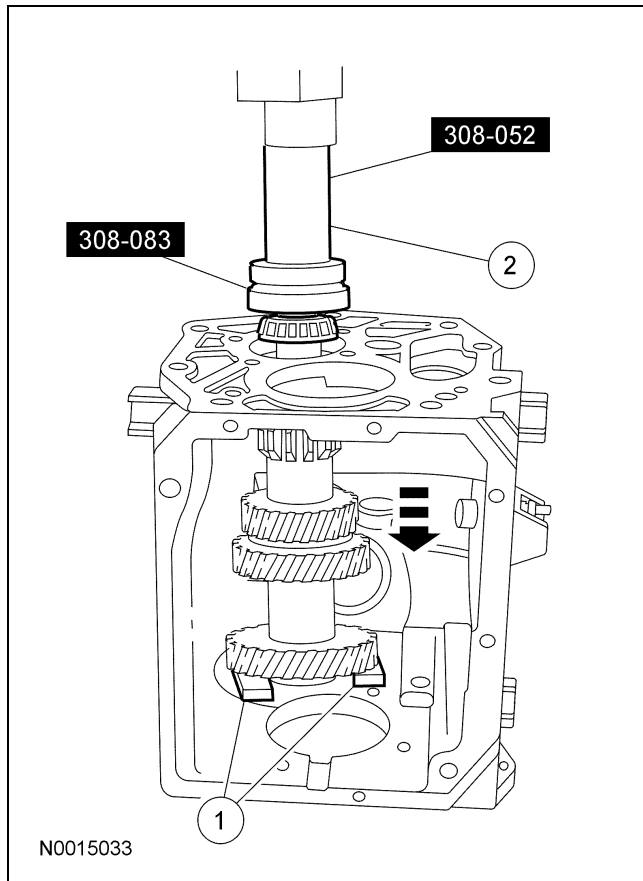

6. Position the reverse idler gear and bushing in the case with the shift lever groove facing the rear of the case. Install the reverse idler gear shaft and the reverse gear overtravel stop.

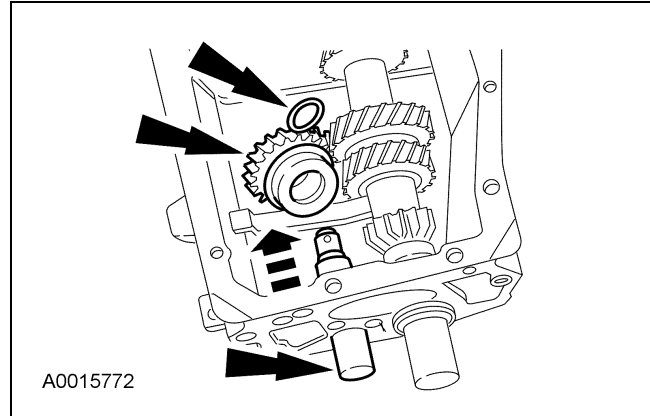

7. Install the rear countershaft bearing cup.

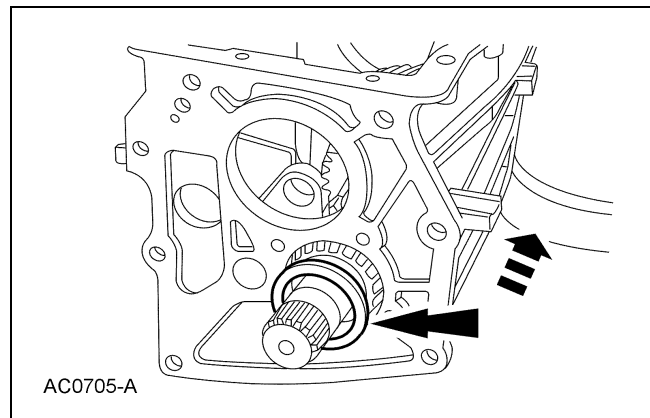

8. **NOTE:** Do not install the shims at this time. Install the countershaft rear bearing retainer.
- Tighten to 21 Nm (15 lb-ft).

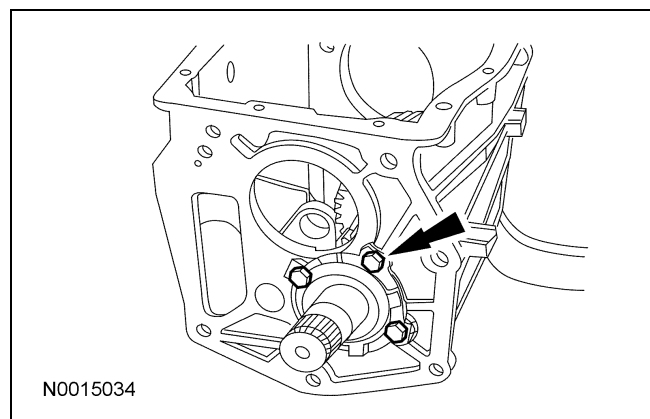

DISASSEMBLY AND ASSEMBLY (Continued)

9. Using the Dial Indicator Gauge with Holding Fixture and Clutch Housing Gauge, measure the countershaft cluster gear end play.
- If the end play is not within specification, remove the countershaft rear bearing retainer and install the necessary thickness shim(s). Reinstall the countershaft rear bearing retainer and recheck the end play.
 - Bend the tabs of the countershaft rear bearing retainer over the bolts when the end play adjustment is complete.

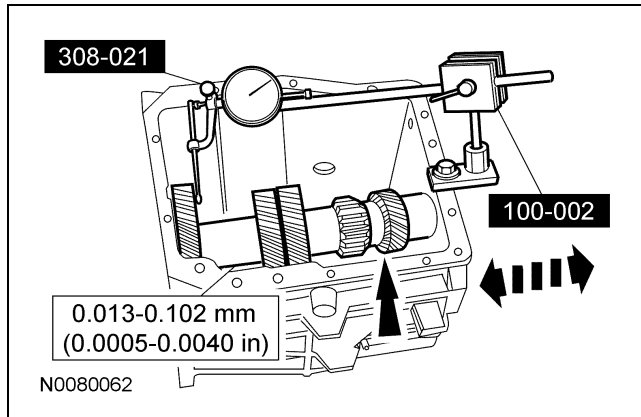

10. Install a new roll pin.

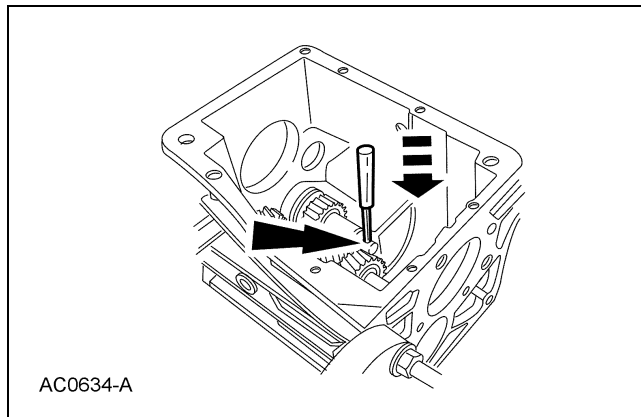

11. Align the reverse gearshift lever, the reverse shift fork and the reverse positioning spring.

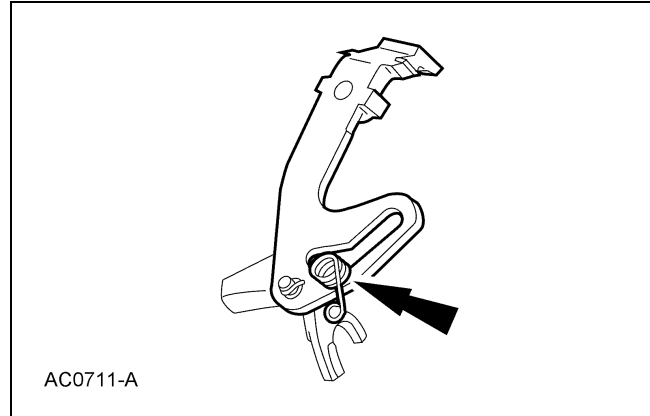

12. **NOTE:** Observe the reverse positioning spring rotation. The spring must rotate counterclockwise into its installed position.

Install the reverse shift fork.

- Place the reverse idler gear and bushing into the NEUTRAL position. Align the reverse shift fork and the reverse idler gear and bushing. Push downward on the reverse shift fork until fully engaged into the reverse idler gear and bushing.

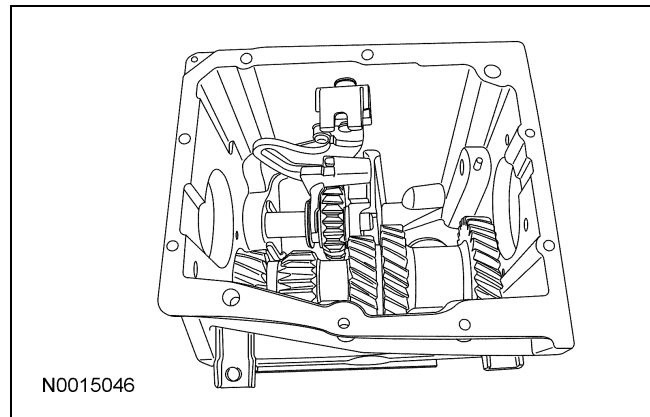

13. Install the output shaft assembly.

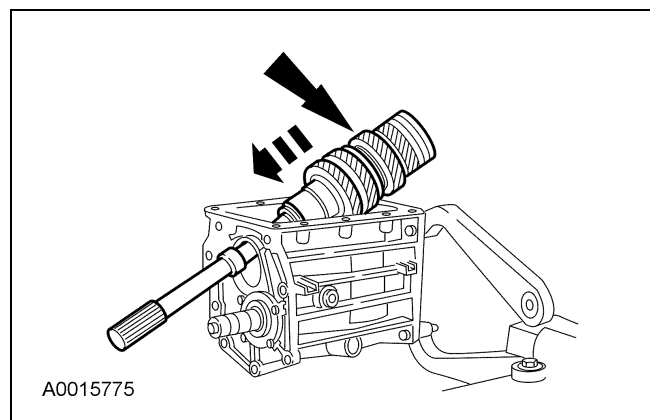

DISASSEMBLY AND ASSEMBLY (Continued)

14. Apply pipe sealant to the shift lever reverse pin threads. Position the looped end of the reverse positioning spring around the shift lever reverse pin. Install the pin.

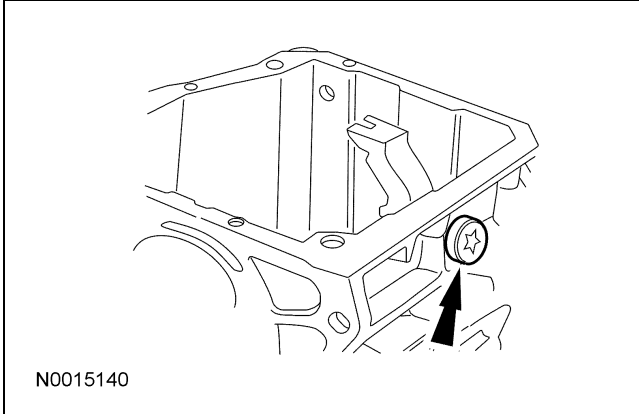

15. **NOTE:** Coat the 15 bearings, the spacer, the thrust bearing and the thrust washer with grease.

Install the roller bearings, the input shaft bearing spacer, the thrust bearing and the thrust washer.

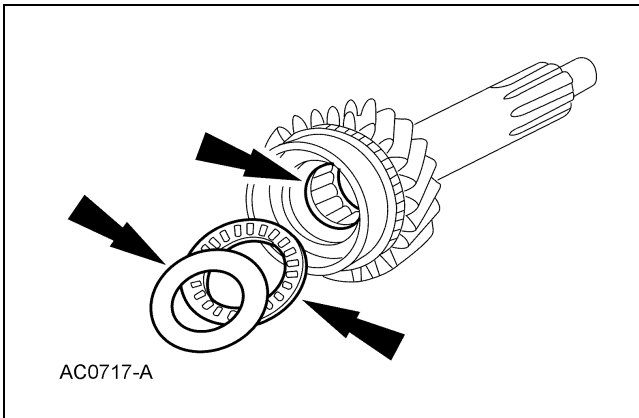

16. Align the notches in the synchronizer blocking ring and the synchronizer hub inserts. Install the 4th gear synchronizer blocking ring.

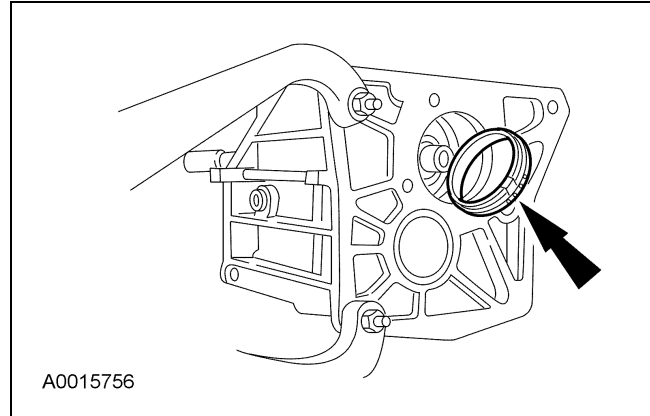

17. **NOTE:** Verify that the 4th speed synchronizer blocking ring is still in position.

Align the flat on the 4th gear clutching teeth with the countershaft cluster gear, then install the input shaft.

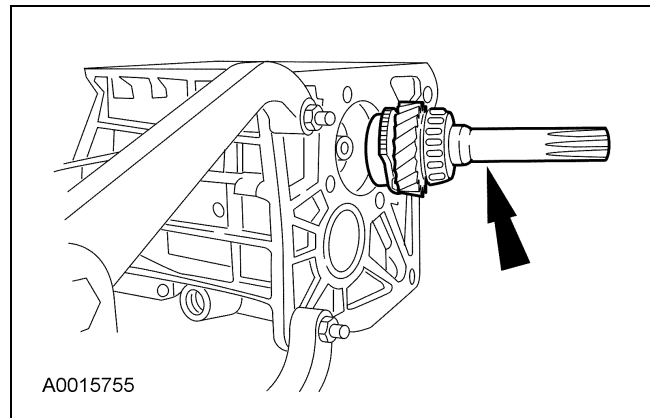

18. **NOTE:** Do not install the end play shims at this time.

NOTE: Do not apply sealant to the input shaft bearing retainer at this time.

Install the bearing race in the bearing retainer.

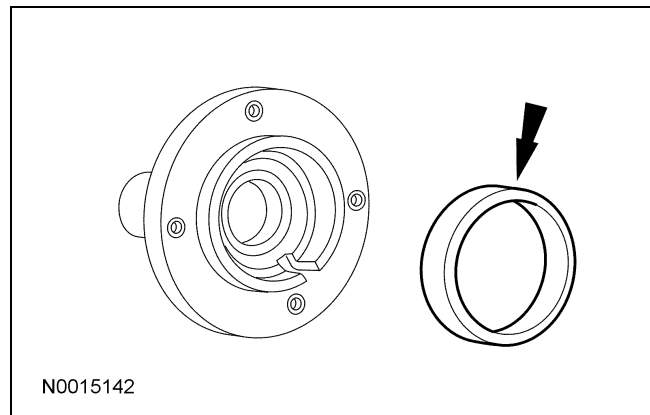

DISASSEMBLY AND ASSEMBLY (Continued)

19. Install the input shaft bearing retainer with the notch facing upward.

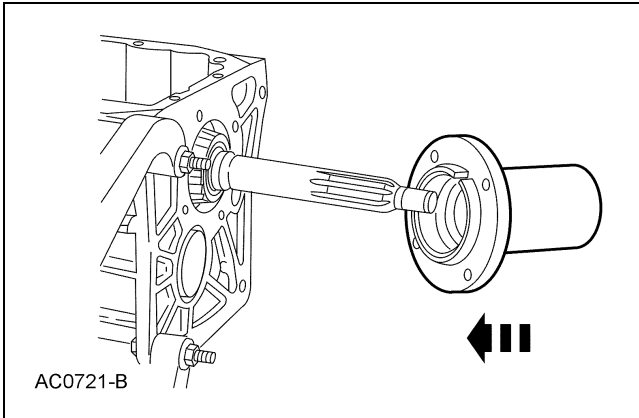

20. Install the 4 input shaft bearing retainer bolts.
- Tighten to 21 Nm (15 lb-ft).

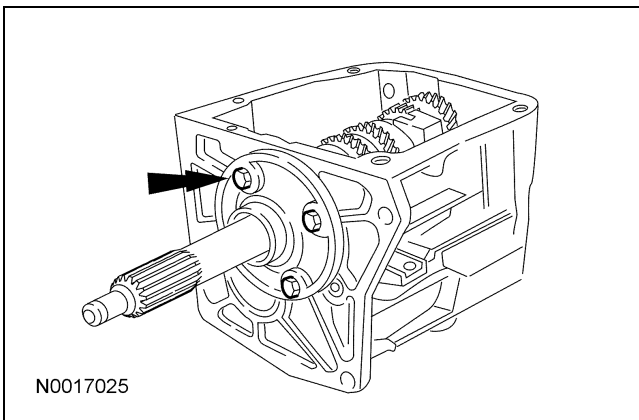

21. Install 5th gear and the output shaft rear bearing cup.

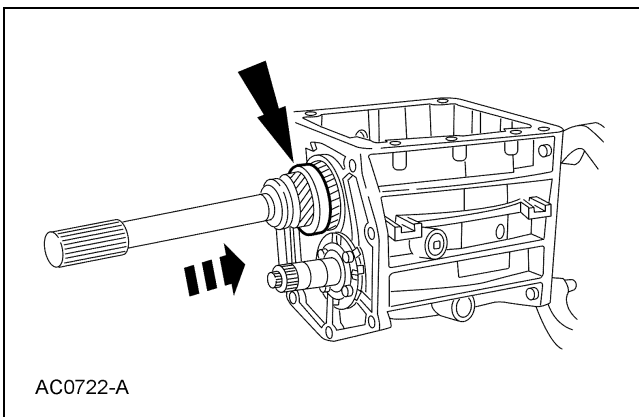

22. Install the reverse gear shift rail. Align the ball stud with the slot in the case and align the reverse gear shift rail with the reverse shift fork. Once the ball stud enters the case, rotate the reverse gear shift rail until the ball aligns with the reverse gearshift lever. Rotate the reverse gear shift rail counterclockwise until the ball stud fully engages the reverse gearshift lever.

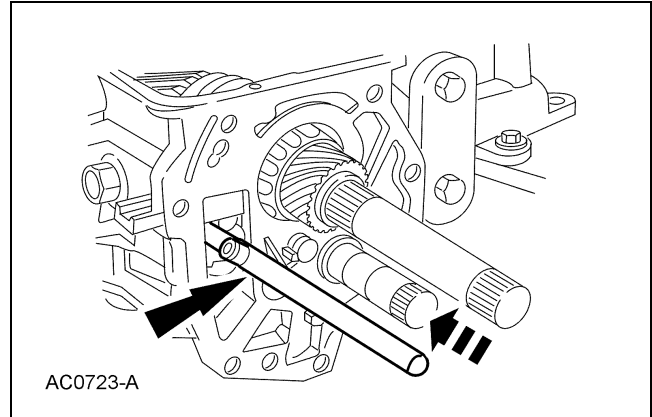

23. Install the 5th gear shifter fork, the synchronizer blocking ring, the synchronizer assembly and the 5th gear shifter fork pin as an assembly.

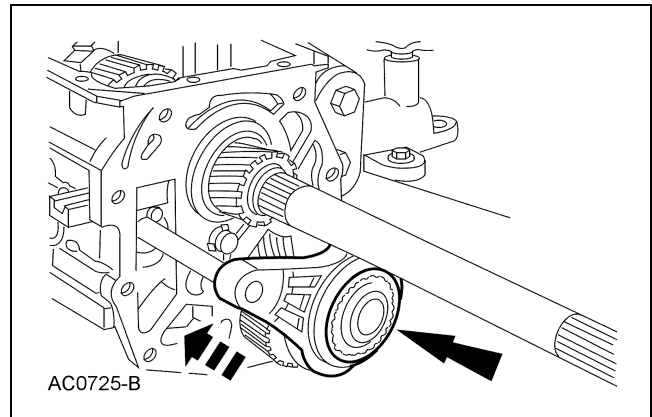

DISASSEMBLY AND ASSEMBLY (Continued)

24. **NOTICE:** To prevent component damage when installing the extension housing, the alignment tab on the reverse brake ring must engage the alignment slot in the extension housing.

Install the synchronizer blocking ring, the reverse brake ring, the thrust washer and a new 5th speed synchronizer retaining snap ring.

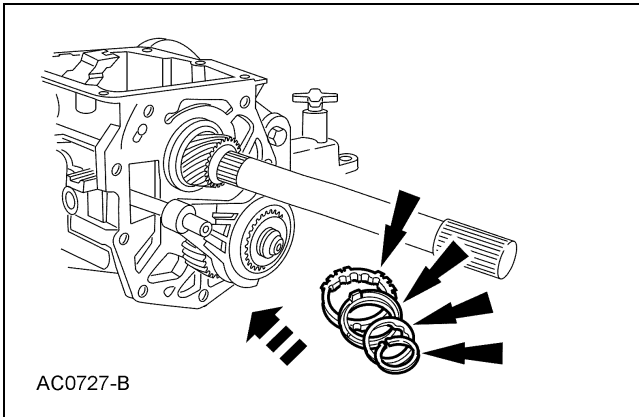

25. Apply pipe sealant to the reversing lamp switch threads and install the switch.

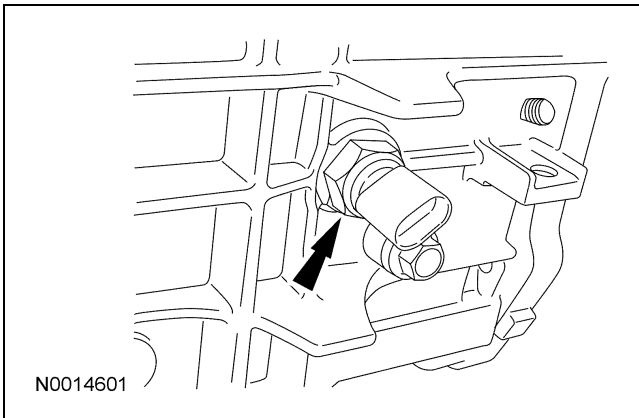

26. Install the reverse gearshift lever retaining clip.

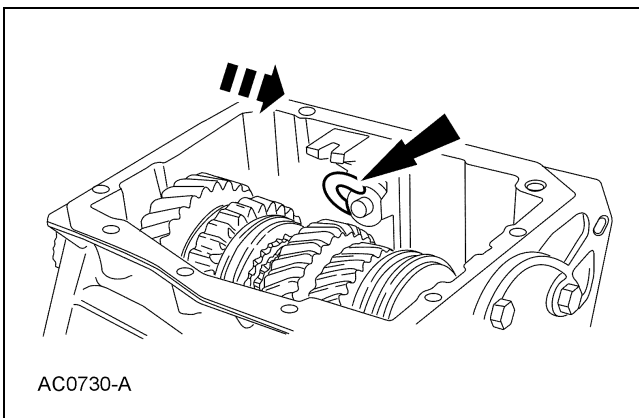

27. **NOTICE:** Do not, under any circumstance, apply silicone sealant to the top of the transmission case. The sealant could fall into the transmission and affect transmission operation.

Apply a 3.2 mm (1/8 in) bead of silicone rubber to the sealing surface on the case cover.

28. **NOTE:** Verify that all of the synchronizers are in the NEUTRAL position and the gear shifter forks in the cover are in the NEUTRAL position.

Position the case cover toward the filler plug side of the transmission and lower it until the gear shifter forks engage the synchronizers. Continue to lower the cover and move it into position to engage the reverse gearshift lever.

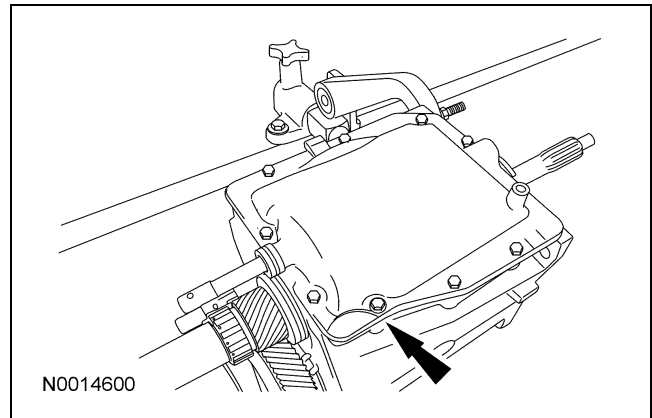

29. Install the 10 transmission case cover bolts.

- Tighten to 12 Nm (106 lb-in).

30. Install a new output shaft bearing and a new snap ring.

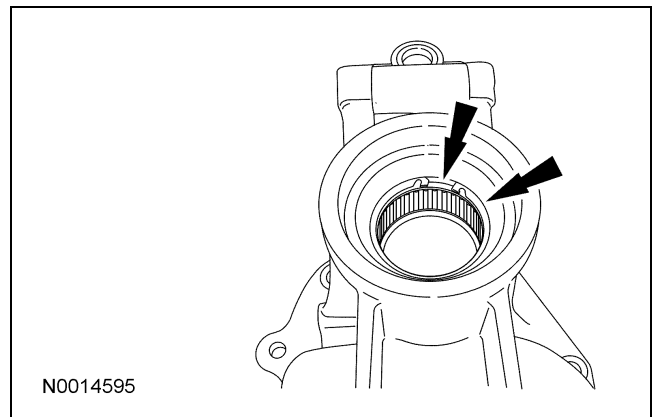

DISASSEMBLY AND ASSEMBLY (Continued)

31. Using the Transmission Extension Housig Oil Seal Installer, install a new output shaft seal.

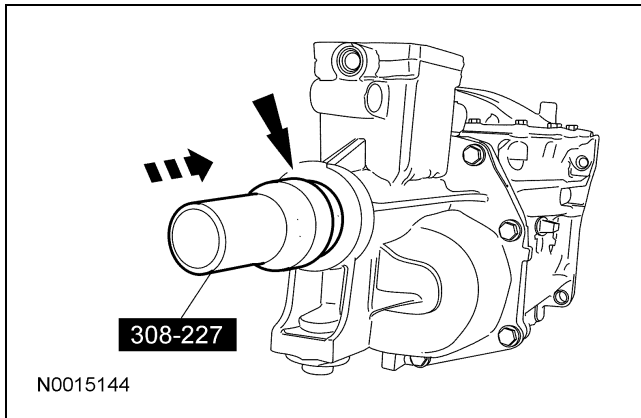

32. Install the large output shaft spacer.

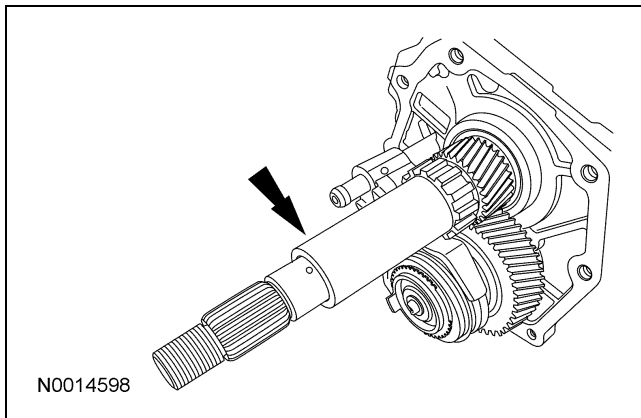

33. Install a new check ball.

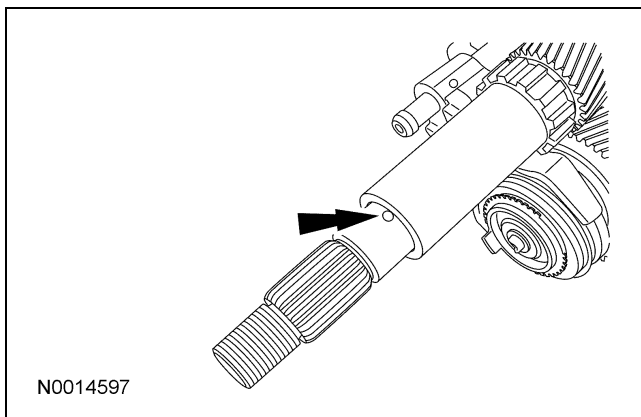

34. Install the small output shaft spacer.

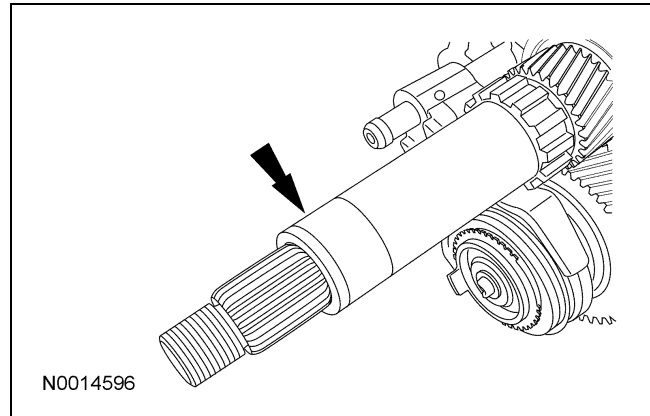

35. Apply a 3.2 mm (1/8 in) bead of silicone rubber to the sealing surface on the extension housing.

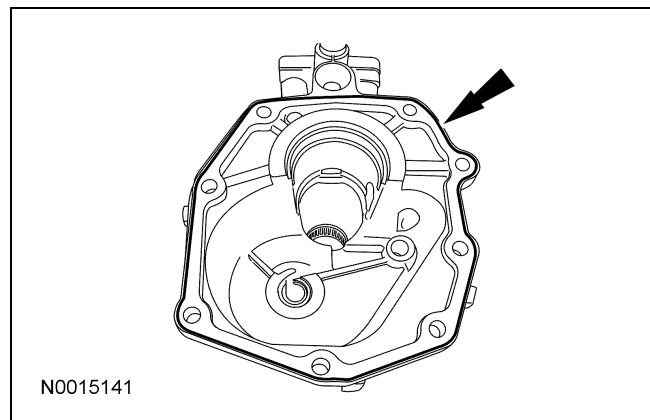

36. Lubricate the detent plate. Position the gearshift offset lever in the extension housing.

DISASSEMBLY AND ASSEMBLY (Continued)

37. **NOTICE:** To prevent component damage, the alignment tab on the reverse brake ring must align with the alignment slot in the extension housing.

NOTE: Verify that the oil pick-up funnel engages the 5th gear synchronizer.

Slide the gearshift offset lever onto the shift shaft and the position the extension housing into place.

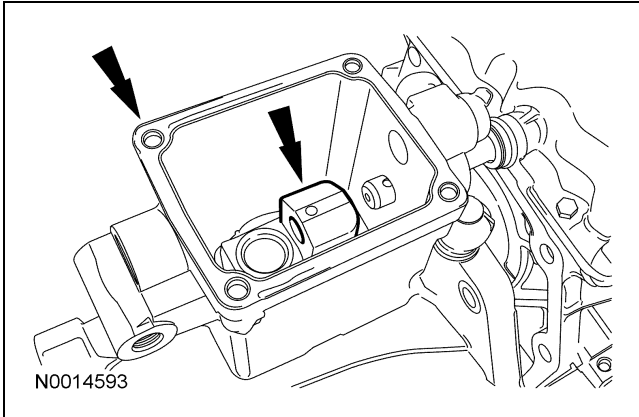

38. Install the identification tag and the 8 extension housing bolts.

- Tighten to 54 Nm (40 lb-ft).

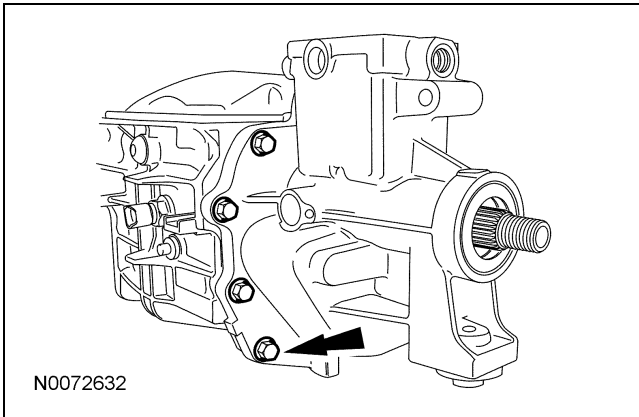

39. Install a new gearshift offset lever roll pin.

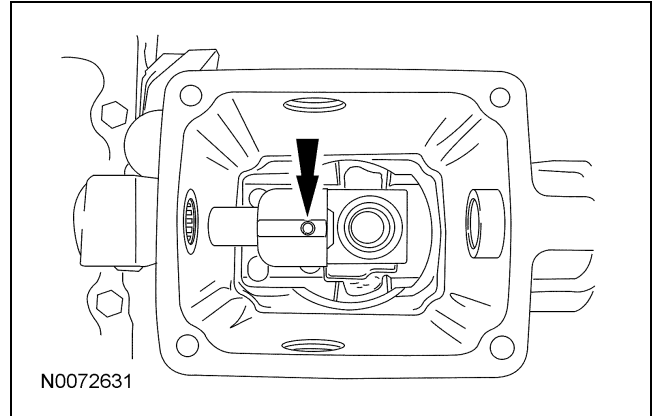

40. Install the shift lever and the gearshift shaft.

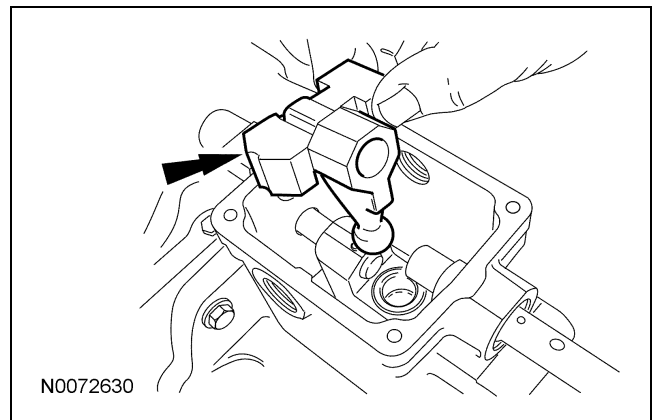

41. Install the shift lever detents.

- Tighten to 40 Nm (30 lb-ft).

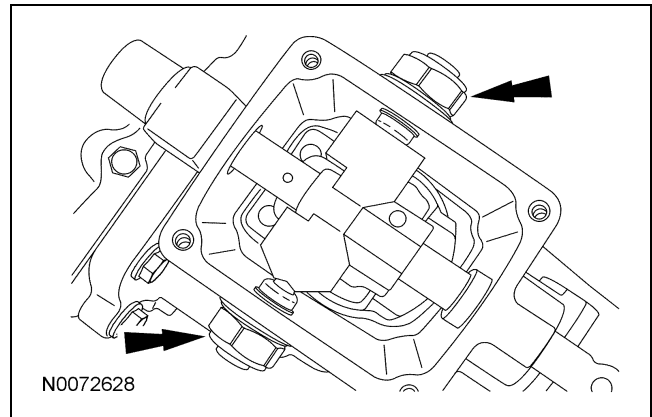

DISASSEMBLY AND ASSEMBLY (Continued)

42. Install a new gearshift lever roll pin.

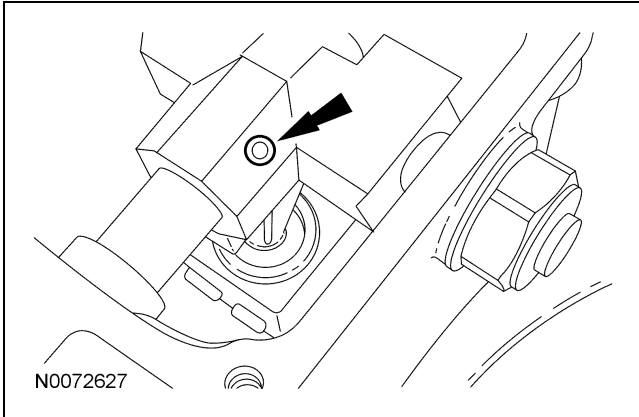

43. Using the Dial Indicator Gauge with Holding Fixture, measure the output shaft end play.
- 1 Place the transmission in a vertical position.
 - 2 Install the Dial Indicator Gauge with Holding Fixture.
 - 3 Push upward on the input shaft and record the dial indicator reading.

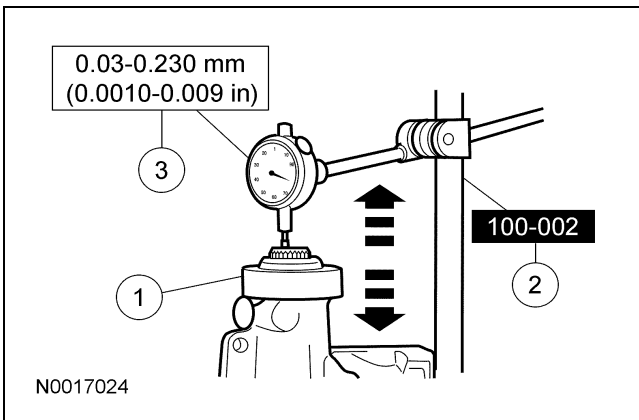

44. **NOTICE:** Although zero end play is the ideal, end play up to 0.230 mm (0.009 in) is an acceptable tolerance. Do not overload the bearings with a shim that is too thick as damage may occur.

NOTE: Select a shim with a thickness equal to the dial indicator reading. This will provide zero end play. Install the thickest shim closest to the front bearing cup to provide support for the cup.

Rotate the transmission to the horizontal position and remove the input shaft bearing retainer. Remove the bearing race and install the necessary shim(s).

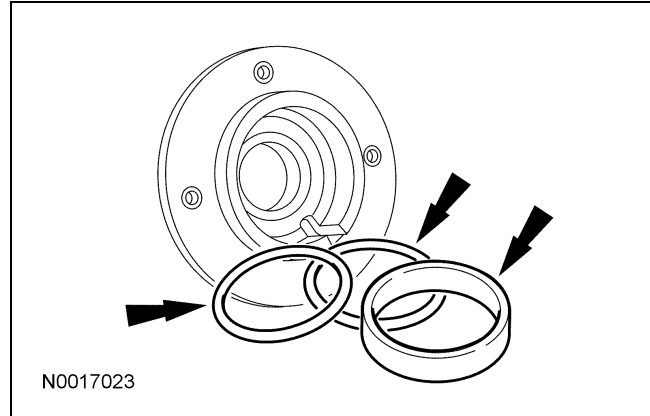

45. Apply a 3.2 mm (1/8 in) bead of silicone rubber to the sealing surface on the input shaft bearing retainer. Do not cover the notch in the input shaft bearing retainer with sealer.
46. Install the input shaft bearing retainer and the 4 bolts.
- Tighten to 21 Nm (15 lb-ft).

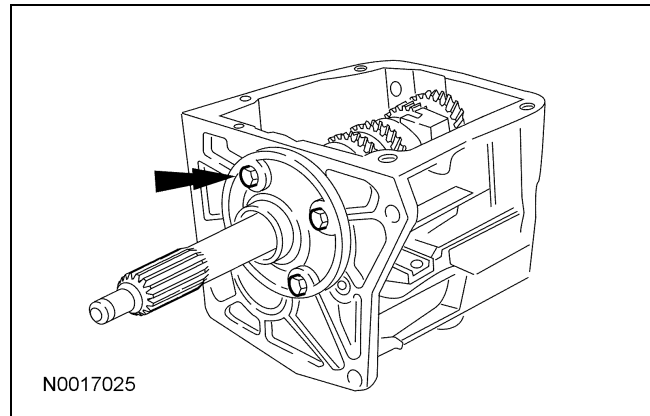

47. Apply a 3.2 mm (1/8 in) bead of silicone rubber to the sealing surface on the gearshift lever.

DISASSEMBLY AND ASSEMBLY (Continued)

48. Install the shift cover plate and the 4 shift cover plate bolts.
- Tighten to 19 Nm (168 lb-in).

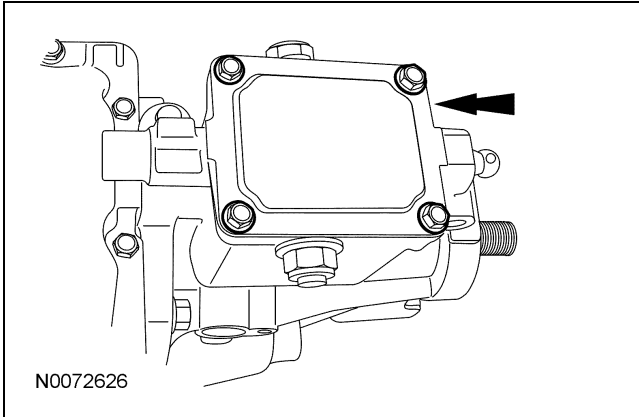

49. **NOTE:** Apply thread sealant to the drain plug threads.
Install the drain plug.
- Tighten to 18 Nm (159 lb-in).

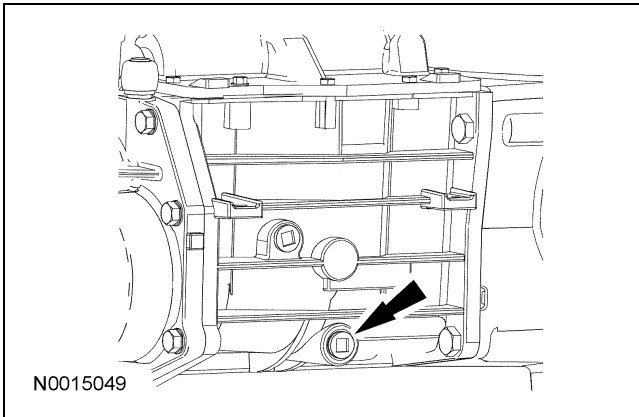

50. Install the Output Shaft Speed (OSS) sensor.
- Tighten to 10 Nm (89 lb-in).

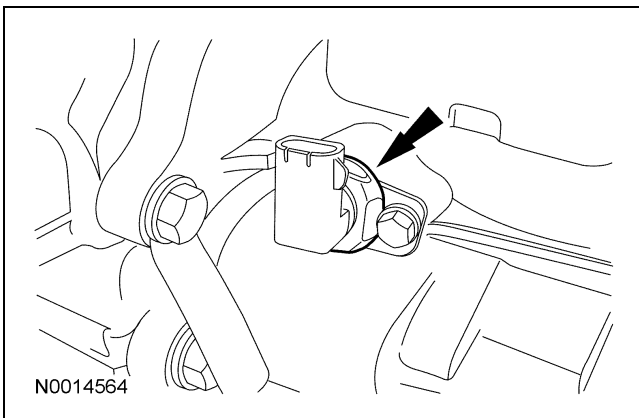

51. Position the output flange onto the output shaft. Install the thrust washer and output flange nut. Tighten until the output flange is fully seated.
52. Remove the output flange nut and thrust washer.
53. Install a new flange seal. Carefully push it through until it is fully seated against the flange and output flange pocket.
54. Install the thrust washer and output flange nut.
- Tighten to 142 Nm (105 lb-ft).
55. Install the clutch housing to the transmission.
- Tighten to 31 Nm (23 lb-ft).

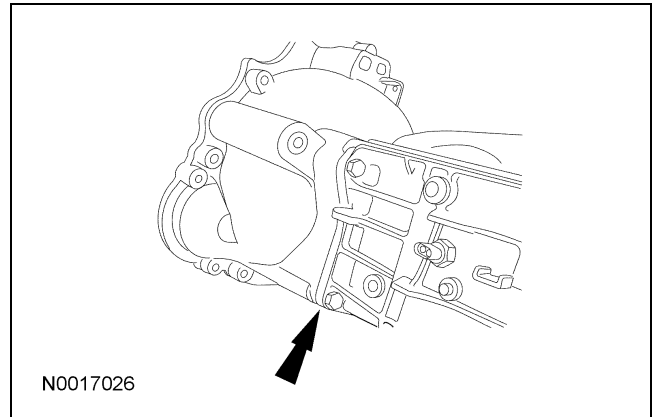

56. Install a new clutch slave cylinder retaining clip.

DISASSEMBLY AND ASSEMBLY (Continued)

57. Install the clutch release slave cylinder.

- Tighten to 9 Nm (80 lb-in).

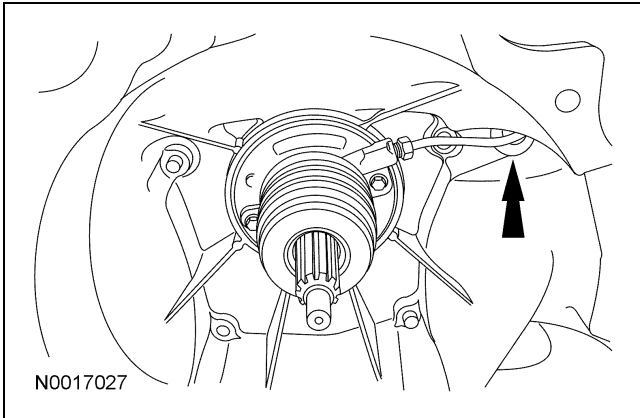

REMOVAL AND INSTALLATION

Transmission

Material

Item	Specification
MERCON® V Automatic Transmission Fluid XT-5-QM (or XT-5-QMC) (US); CXT-5-LM12 (Canada)	MERCON® V
Premium Long-Life Grease XG-1-C or XG-1-K (US); CXG-1-C (Canada)	ESA-M1C75-B
Threadlock and Sealer TA-25	WSK-M2G351-A5

- NOTE:** Before installing the transmission, the input shaft must be cleaned and lubricated with a small amount of grease.
Position the transmission to the engine.
- NOTE:** Insert the clutch hydraulic tube into the clutch slave cylinder and install the clip before tightening the transmission-to-engine bolts.
Install the 8 transmission-to-engine bolts and the separator plate bolt.
 - Tighten to 45 Nm (33 lb-ft).
- Install a new exhaust coupler. Connect the intermediate pipe to the catalytic converter.
 - Tighten to 54 Nm (40 lb-ft).

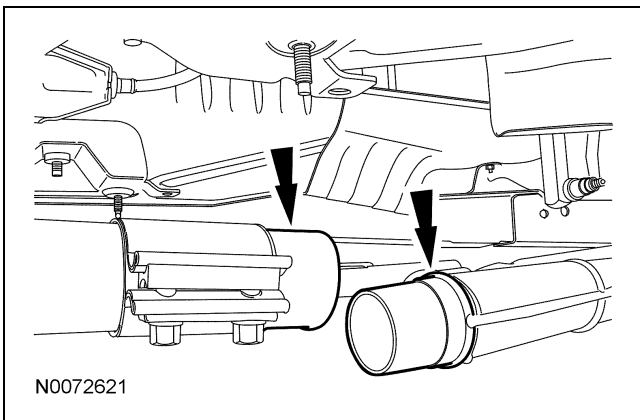

- NOTE:** The hump side on the crossmember goes down.
Install the transmission crossmember. For additional information, refer to Section 502-00.

- NOTE:** Clean the starter motor mounting flange and mating surface of the starter motor to ensure a proper ground connection.

Install the starter motor and the 2 starter motor bolts.

- Tighten to 25 Nm (18 lb-ft).

- Connect the wiring harness to the transmission. Connect the following:

- Catalyst monitor sensor electrical connector
- Reverse lamp switch electrical connector
- Wiring harness clips
- Output Shaft Speed (OSS) sensor electrical connector

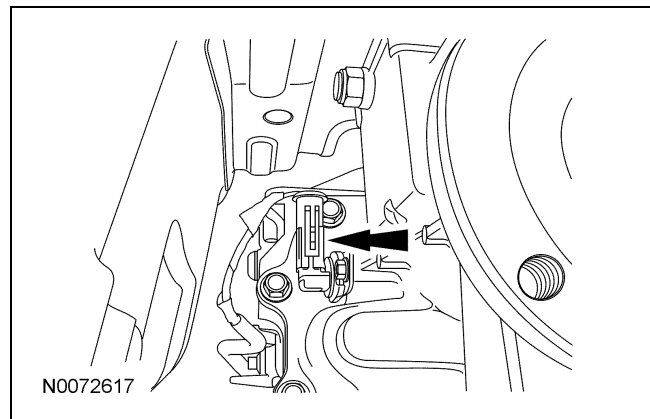
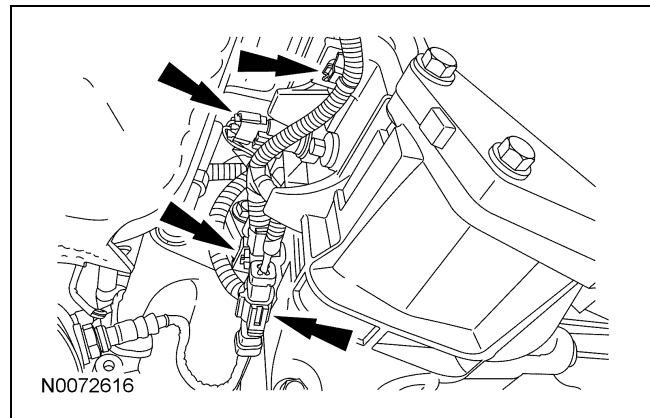

- Connect the shift linkage to the transmission.
 - Tighten to 40 Nm (30 lb-ft).
- NOTE:** Align the index marks made during removal.
Install the driveshaft and the 4 driveshaft bolts.
 - Tighten to 103 Nm (76 lb-ft).

REMOVAL AND INSTALLATION (Continued)

9. Check, and as necessary, fill the transmission with transmission fluid. Apply threadlock and sealer to the fill plug threads and install the fill plug.
 - Total fill capacity is 2.6L (2.8 pt).
 - Tighten to 18 Nm (159 lb-in).
 10. Connect the battery ground cable. For additional information, refer to Section 414-01.
 11. Fill the brake and clutch reservoir. Bleed the clutch hydraulic system. For additional information, refer to Section 308-00.
-

SPECIFICATIONS

Material

Item	Specification	Fill Capacity
Clear Silicone Rubber TA-32	ESB-M4G92-A	—
MERCON® V Automatic Transmission Fluid XT-5-QM (or XT-5-QMC) (US); CXT-5-LM12 (Canada)	MERCON® V	3.0L (6.3 pt)
Premium Long-Life Grease XG-1-C or XG-1-K (US); CXG-1-C (Canada)	ESA-M1C75-B	—
Threadlock and Sealer TA-25	WSK-M2G351-A5	—

General Specifications

Item	Specification
End Play	
Countershaft cluster gear end play	0.026-0.126 mm (0.001-0.004 in)
Input shaft end play	0.027-0.127 mm (0.001-0.005 in)
Synchronizer	
Synchronizer blocking ring to conical face runout	0.5 mm (0.02 in)
Transmission	
Physical weight	55.6 kg (123 lb)

Torque Specifications

Description	Nm	lb-ft	lb-in
Clutch housing-to-transmission main case bolt	32	24	—
Crossmember-to-frame bolts	62	46	—
Crossmember-to-transmission bolt	70	52	—
Detent plugs	28	21	—
Drain plug	27	20	—
Extension housing-to-transmission main case bolt	32	24	—
Fifth/reverse lockout side bolt	20	—	177
Fifth/reverse lockout top bolt	20	—	177
Fill plug	25	18	—
Lock plate bolts	31	23	—
Output flange nut	142	105	—
Output Shaft Speed (OSS) sensor bolt	10	—	89
Reverse idler gear bolt	27	20	—
Reversing lamp switch	27	20	—
Spacer plate bolt	35	26	—
Starter motor bolt	25	18	—
Subframe cross brace nut	48	35	—
Transmission-to-engine bolt	45	33	—
Transmission shift arm bolt	40	30	—

DESCRIPTION AND OPERATION

Manual Transmission

The TR3650 5-speed manual transmission features the following:

- The 5th speed gear functions as an overdrive gear
- The forward gears are synchronized and helical cut
- The reverse gear operates through a constant-mesh, fully synchronized system
- The shift interlock system prevents the engagement of more than one gear
- The countershaft is serviced as an assembly
- An aluminum main case, extension housing and bellhousing

The transmission function is to move the vehicle from a rest position to motion. This is done by transferring the engine torque, through the transmission, to the vehicle rear wheels. The transmission input shaft receives power when the clutch is engaged. Torque flows through the input shaft to the drive gear. Torque travels downward to the countershaft drive gear and is delivered along the countershaft to all the countershaft gears. Torque is then transferred upward to the engaged mainshaft gear. The transmission uses a system of mainshaft gears to change the speed and torque relationship between the engine crankshaft and the transmission output shaft.

Transmission Identification

The transmission identification tag is located under the lower bolt that retains the extension housing to the main case.

Transmission Identification

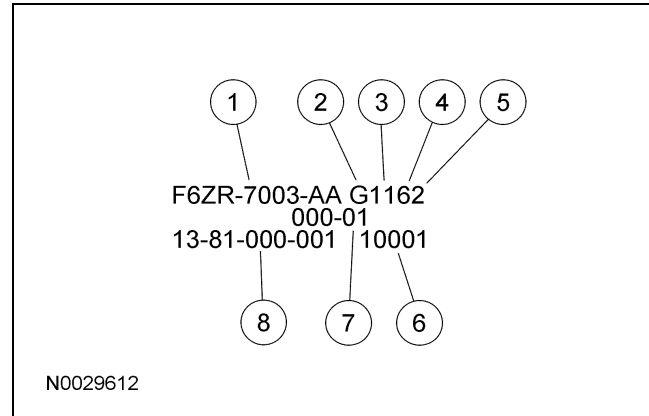

Item	Part Number	Description
1	—	Transmission assembly number
2	—	Build date code — month
3	—	Build date code — day
4	—	Build date code — year
5	—	Shift number
6	—	Serial number
7	—	Service repair code
8	—	Identification number located on left lower side of transmission case

DIAGNOSIS AND TESTING

Manual Transmission

Refer to Section 308-00.

GENERAL PROCEDURES

Transmission Draining and Filling

Material

Item	Specification
MERCON® V Automatic Transmission Fluid XT-5-QM (or XT-5-QMC) (US); CXT-5-LM12 (Canada)	MERCON® V
Threadlock and Sealer TA-25	WSK-M2G351-A5

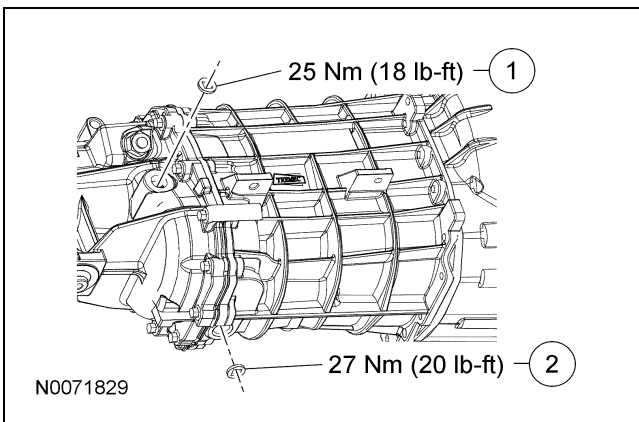
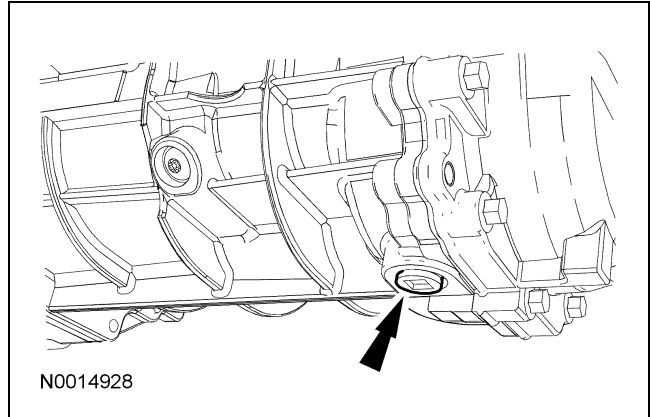

Item	Part Number	Description
1	7A010	Filler plug
2	7A010	Drain plug

1. With the vehicle in NEUTRAL, position it on a hoist. For additional information, refer to Section 100-02.
2. **NOTE:** Drain the transmission while the transmission fluid is warm.
NOTE: Position a drain pan under the transmission.
Remove the drain plug and drain the transmission.

3. Clean the drain plug. Apply threadlock and sealer and install the drain plug.
 - Tighten to 27 Nm (20 lb-ft).
4. **NOTE:** Prior to removal, clean the area around the fill plug.
Remove the fill plug.

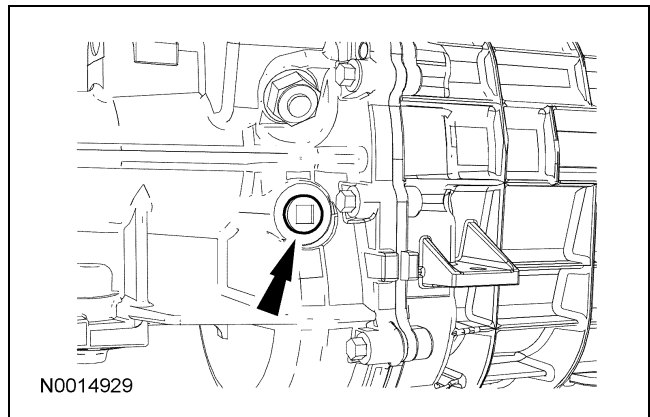

5. **NOTE:** Do not overfill the transmission. This will cause transmission fluid to be forced out of the case.
Fill the transmission with the recommended fluid.
 - Make sure the fluid is 12.7 mm (0.5 in) below the filler opening for the correct fluid level. Using a tie strap, measure an inch from the end and bend it at a 90-degree angle, place it in the filler opening and check the fluid. Adjust the fluid level as necessary.

GENERAL PROCEDURES (Continued)

6. Apply threadlock and sealer and install the fill plug.
 - Tighten to 25 Nm (18 lb-ft).
-

IN-VEHICLE REPAIR

Output Shaft Speed (OSS) Sensor

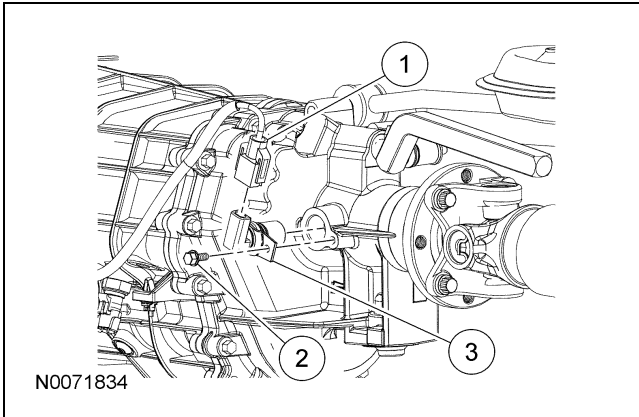

Item	Part Number	Description
1	—	Output Shaft Speed (OSS) sensor electrical connector
2	—	OSS sensor bolt
3	—	OSS sensor

Removal and Installation

1. With the vehicle in NEUTRAL, position it on a hoist. For additional information, refer to Section 100-02.
2. Disconnect the OSS electrical connector.

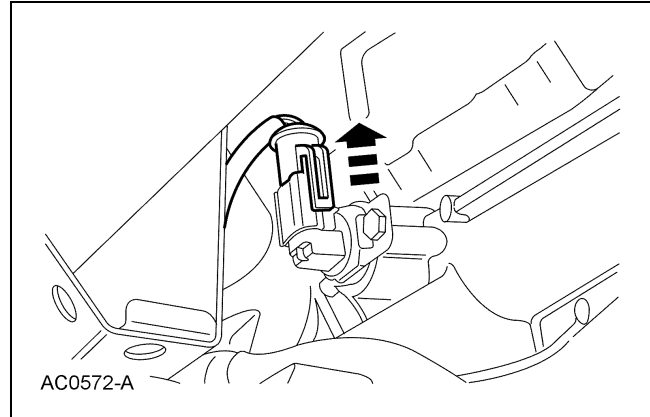

3. Remove the OSS sensor bolt, then remove OSS sensor.

- To install, tighten to 10 Nm (89 lb-in).

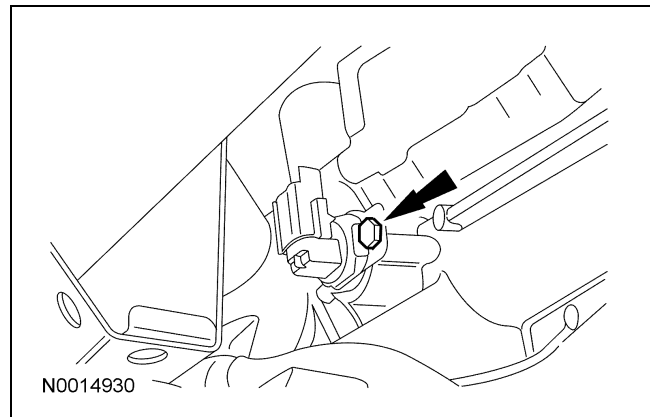

4. To install, reverse the removal procedure.

REMOVAL AND INSTALLATION

Transmission

Removal

1. With the vehicle in NEUTRAL, position it on a hoist. For additional information, refer to Section 100-02.
2. Disconnect the battery ground cable. For additional information, refer to Section 414-01.
3. Remove the catalytic converter H-pipe. For additional information, refer to Section 309-00.
4. Remove the driveshaft. For additional information, refer to Section 205-01.
5. Remove the 3 starter motor bolts and position the starter motor aside.

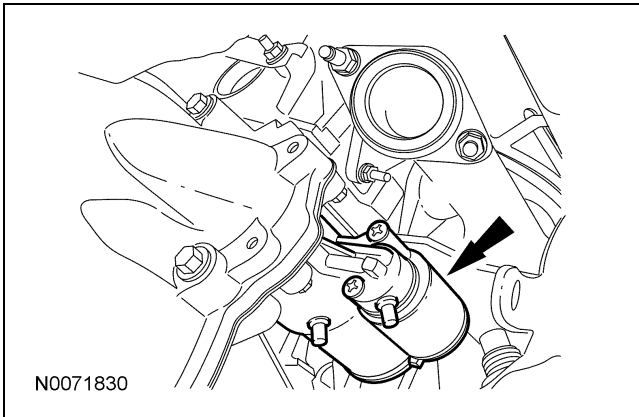

6. Remove the 4 subframe cross brace nuts and the subframe cross brace.

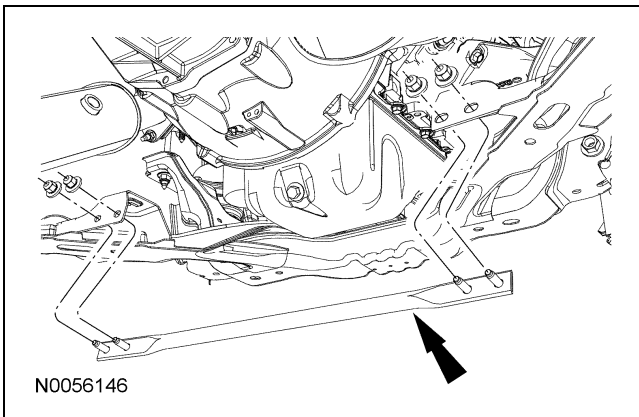

7. Disconnect the reverse lamp switch electrical connector. Disconnect the wiring harness from the transmission.

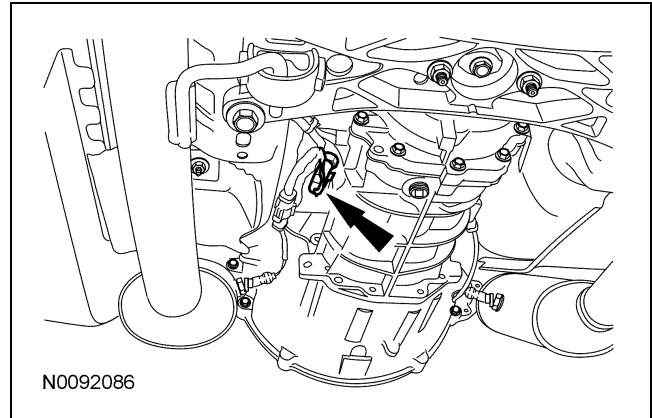

8. Disconnect the Output Shaft Speed (OSS) sensor electrical connector. Disconnect the wiring harness from the transmission.

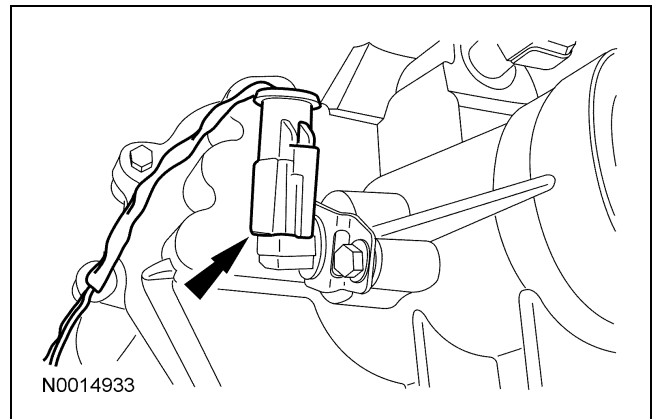

9. If transmission disassembly is necessary, drain the transmission fluid.

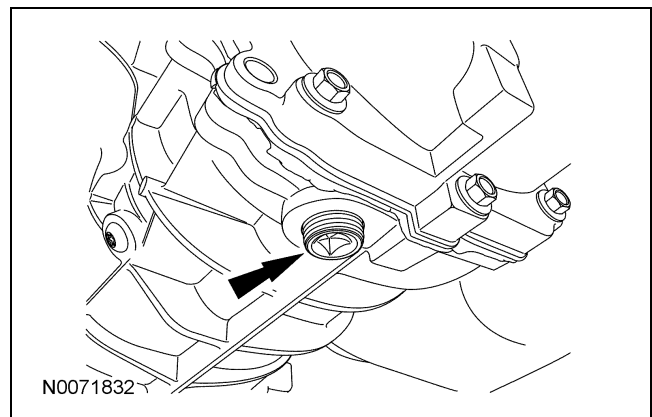

REMOVAL AND INSTALLATION (Continued)

10. Position a transmission jack and support the transmission.

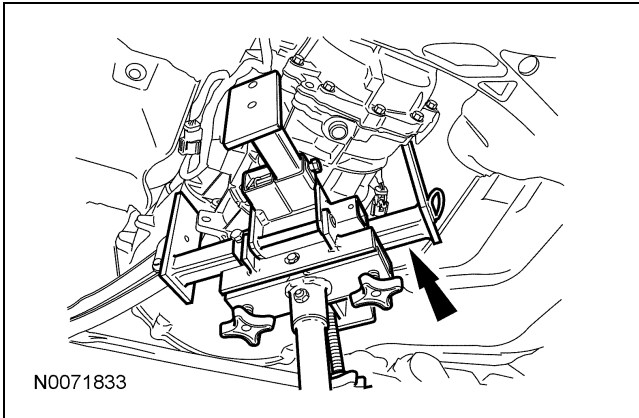

11. **NOTE:** Take note that the hump side of the crossmember goes up.

Remove the transmission crossmember. For additional information, refer to Section 502-00.

12. Lower the transmission 25.4 mm (1 in). Disconnect the shift linkage from the transmission.

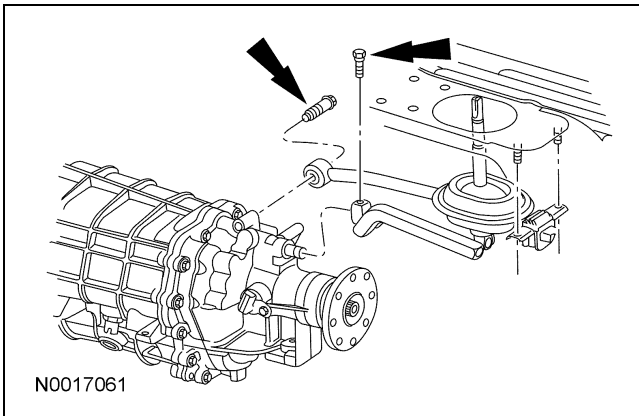

13. Detach the wire harness retaining clip from the transmission.

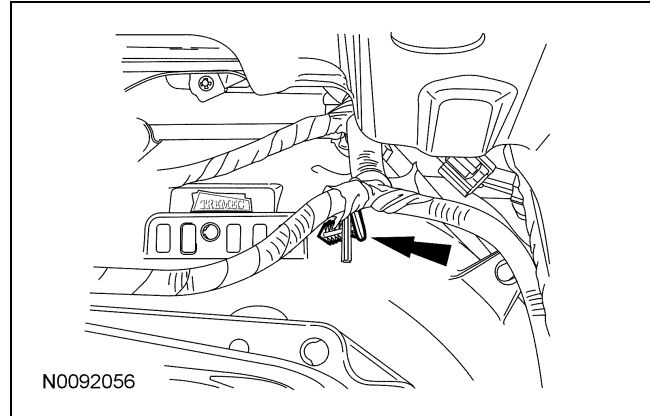

14. **NOTICE:** Do not spill brake fluid on painted or plastic surfaces or damage to the surface may occur. If brake fluid is spilled onto a painted or plastic surface, immediately wash the surface with water.

Release the clutch hydraulic tube clip and separate the connector from the clutch slave cylinder.

15. Remove the 2 spacer plate bolts.
16. Remove the 7 transmission-to-engine bolts.
17. Rotate the transmission 30 degrees counterclockwise. Securely strap the transmission to the transmission jack.

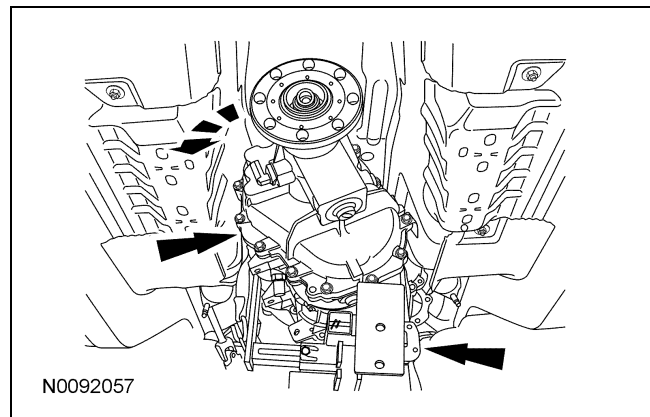

18. Pull the transmission rearward until the input shaft is clear of the pressure plate, then lower the transmission from the vehicle.

DISASSEMBLY AND ASSEMBLY

Transmission

Special Tool(s)

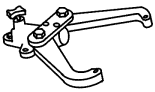
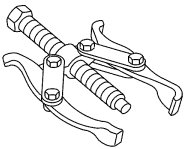
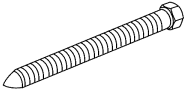
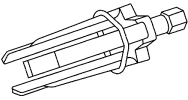
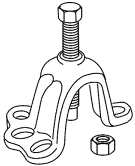
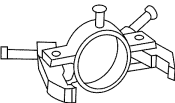
 <p>ST1186-A</p>	<p>Holding Fixture, Transmission 307-003 (T57L-500-B)</p>
 <p>ST2026-A</p>	<p>Puller, 2 Jaw 205-D072 (D80L-1002-L) or equivalent</p>
 <p>ST1304-A</p>	<p>Removal Screw, Bearing Tube 308-092 (T84T-7025-B)</p>
 <p>ST2200-A</p>	<p>Remover, Bushing 307-001 (TOOL-1175-AC)</p>
 <p>ST2272-A</p>	<p>Remover, Front Wheel Hub 205-D070 (D93P-1175-B) or equivalent</p>
 <p>ST1305-A</p>	<p>Remover, Mainshaft Bearing 308-058 (T77J-7025-H)</p>

(Continued)

Special Tool(s)

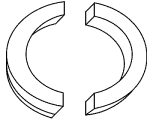
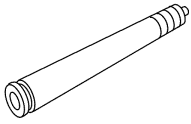
 <p>ST1306-A</p>	<p>Remover, Mainshaft Bearing 308-059 (T77J-7025-J)</p>
 <p>ST2163-A</p>	<p>Remover/Installer Bearing Tube 308-024 (T75L-7025-B)</p>

Disassembly

NOTE: If any roll pins, retaining rings or bearings are removed during disassembly, install new components. Install bearings and bearing cups as a set.

NOTE: For additional information, refer to the exploded view under the Assembly procedure in this section.

1. Clean the transmission exterior with solvent and dry with compressed air. During disassembly, clean all components with solvent and dry with compressed air.

DISASSEMBLY AND ASSEMBLY (Continued)

2. Attach the transmission to the Transmission Holding Fixture.

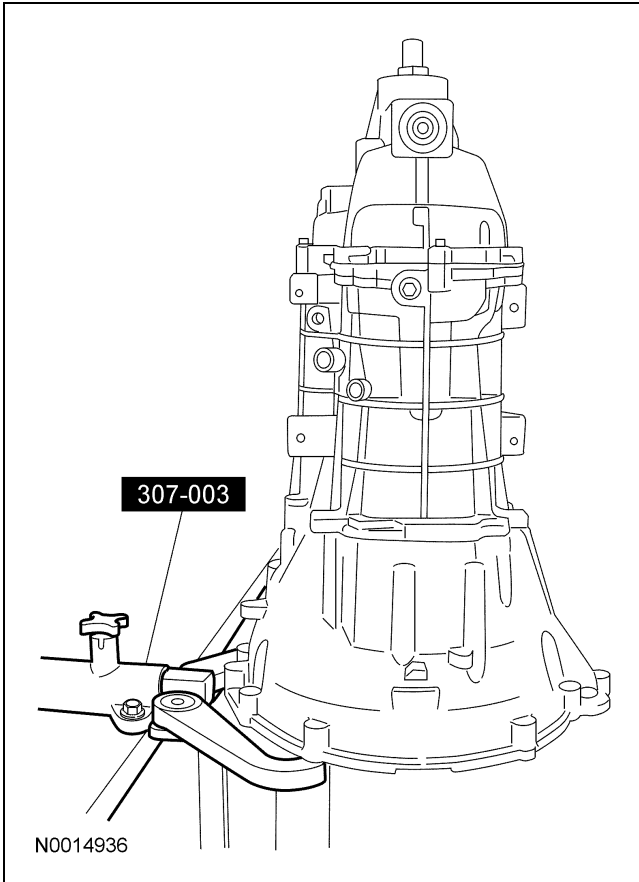

3. Remove the output flange nut, washer and oil seal.

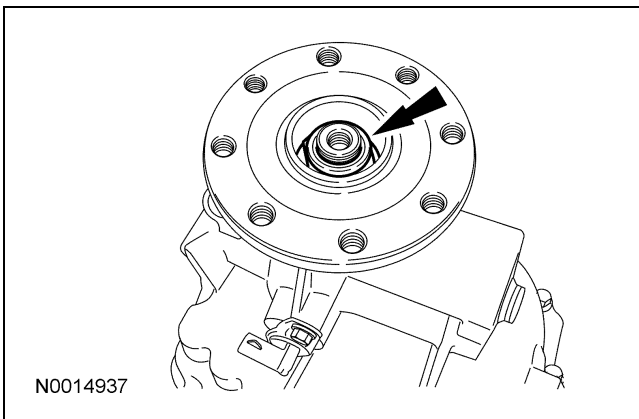

4. Using the Front Wheel Hub Remover, remove the output flange.

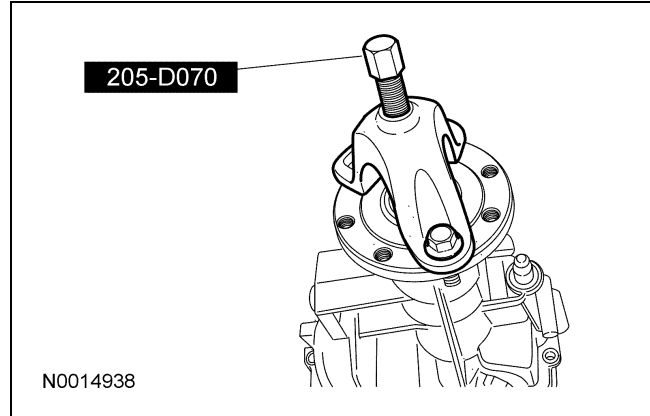

5. **NOTE:** Position a drain pan under the transmission.

Remove the drain plug, then rotate the transmission to a horizontal position and drain the fluid.

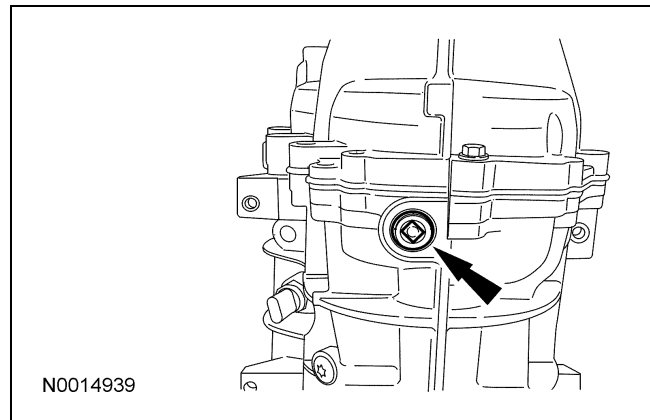

6. Using the Bushing Remover, remove the extension housing fluid seal.

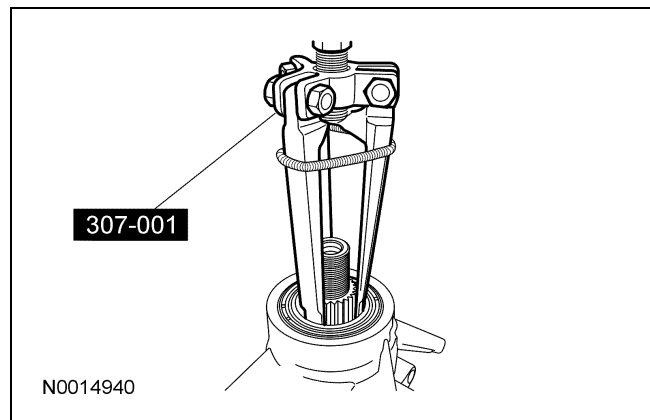

DISASSEMBLY AND ASSEMBLY (Continued)

7. Remove the Output Shaft Speed (OSS) sensor bolt and the OSS sensor.

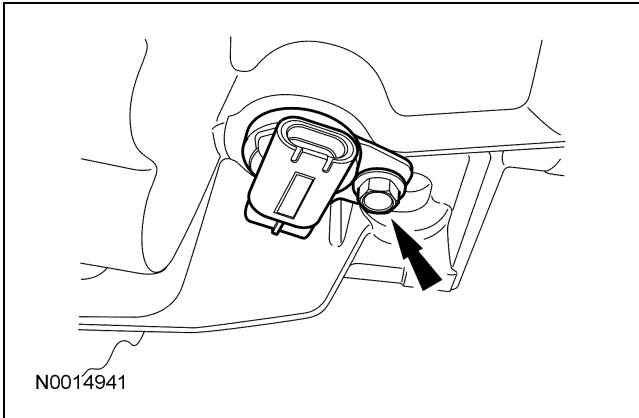

8. Remove the reversing lamp switch.

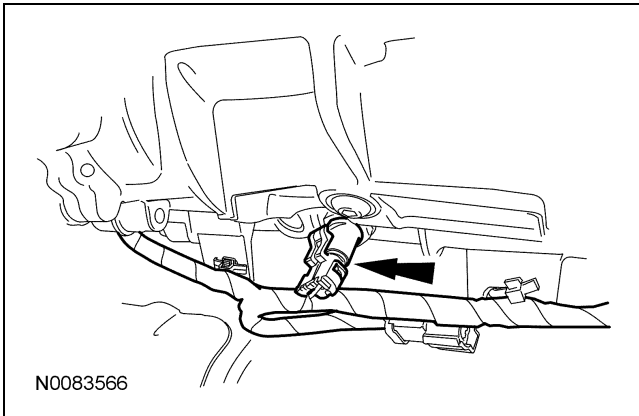

9. Remove the 12 extension housing bolts.

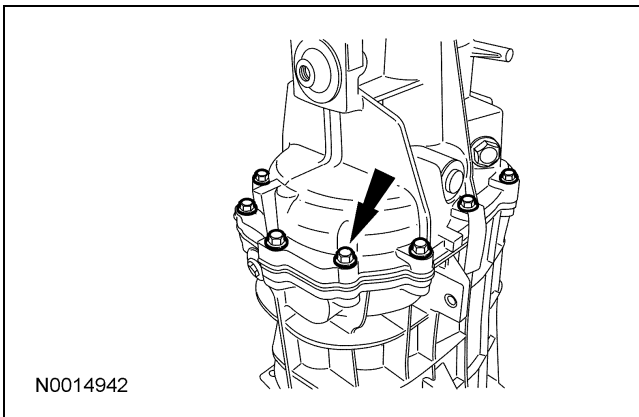

10. Using a flat-blade screwdriver, separate the extension housing, then remove the gearshift offset lever from the transmission case, then remove the extension housing.
- Remove and discard the split pin from the gearshift offset lever during removal.

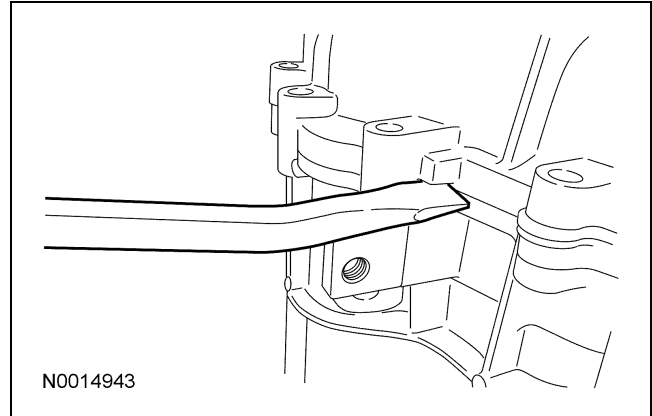

11. Remove the 5th/reverse gear lockout bolt.

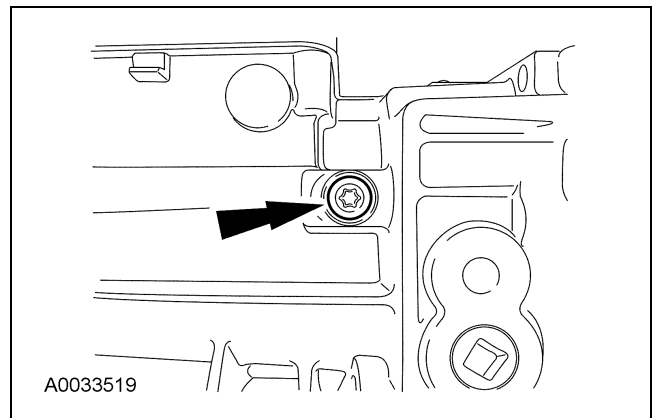

12. Remove and discard the snap ring.

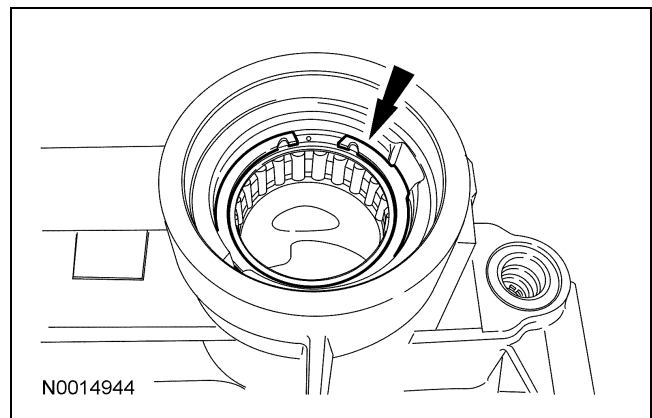

DISASSEMBLY AND ASSEMBLY (Continued)

13. **NOTE:** Always install a new bearing race if installing a new bearing.

Remove the output shaft bearing.

- Inspect the bearing, install a new bearing if necessary.

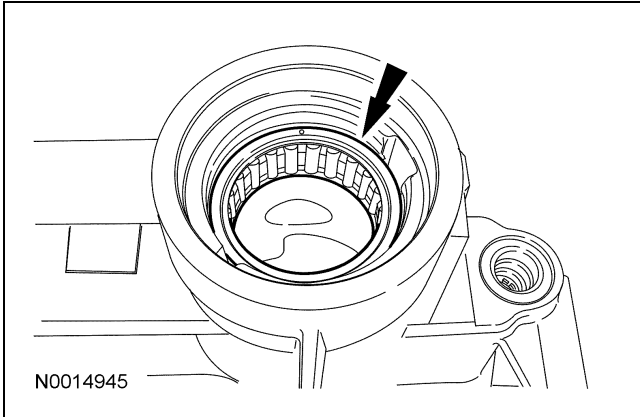

14. Using the Bearing Tube Remover/Installer with the Bearing Tube Removal Screw and the Mainshaft Bearing Remover (308-058) with Mainshaft Bearing Remover (308-059), remove the output shaft bearing race.

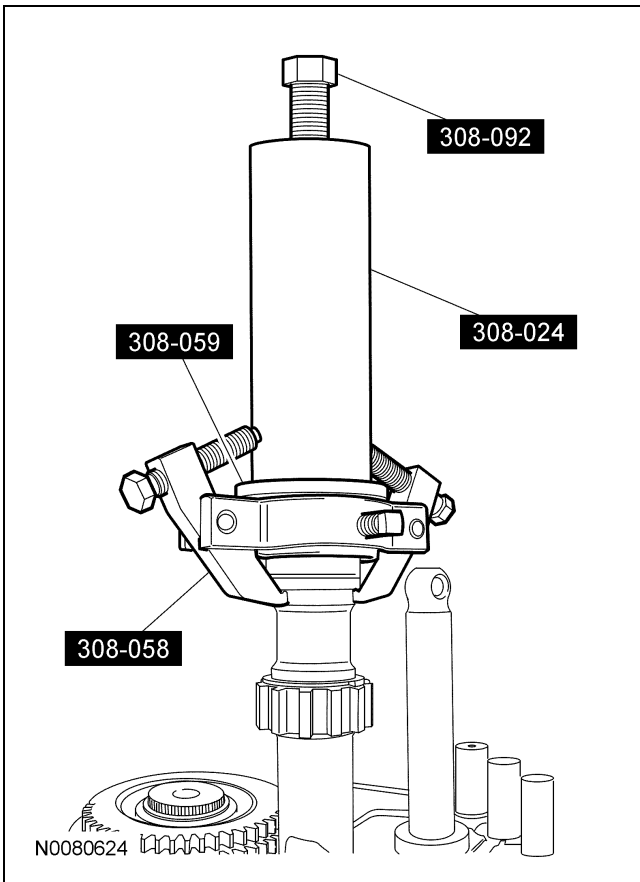

15. Remove the bearing race spacer.

16. Remove the OSS sensor tone wheel retaining ring.

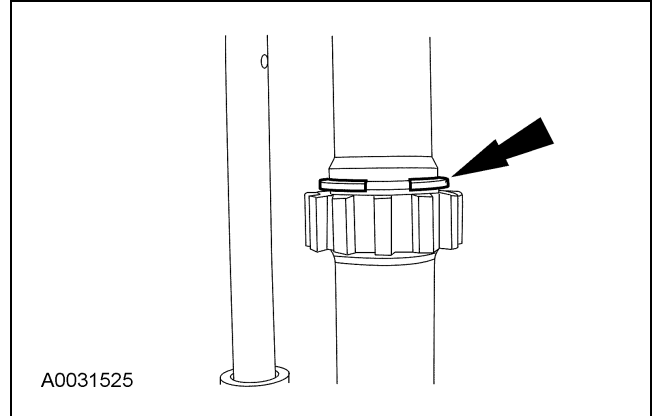

17. Using the Bearing Tube Remover/Installer with the Bearing Tube Removal Screw and the Mainshaft Bearing Remover (308-058) with Mainshaft Bearing Remover (308-059), remove the OSS sensor tone wheel.

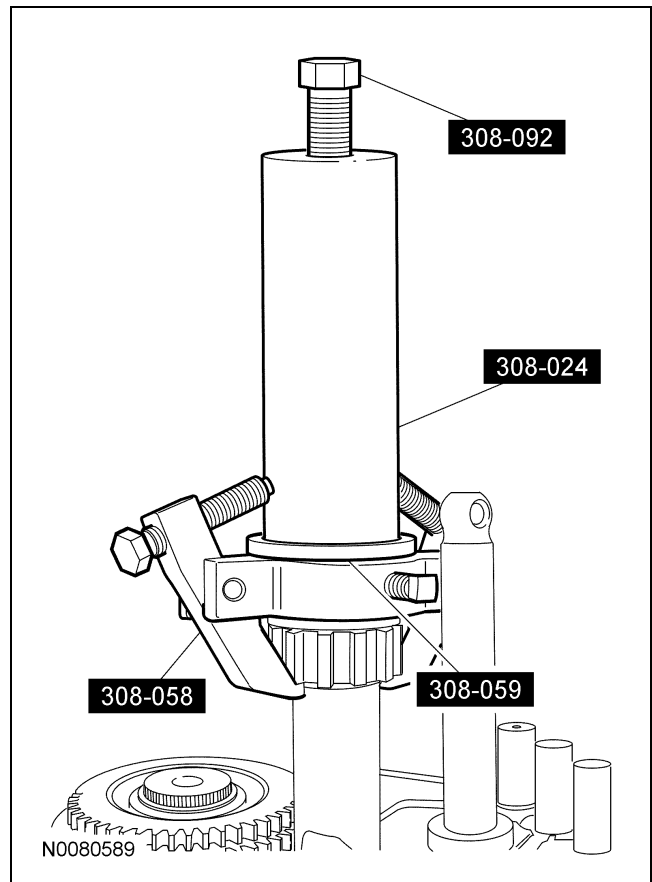

DISASSEMBLY AND ASSEMBLY (Continued)

18. Remove the OSS sensor tone wheel check ball.

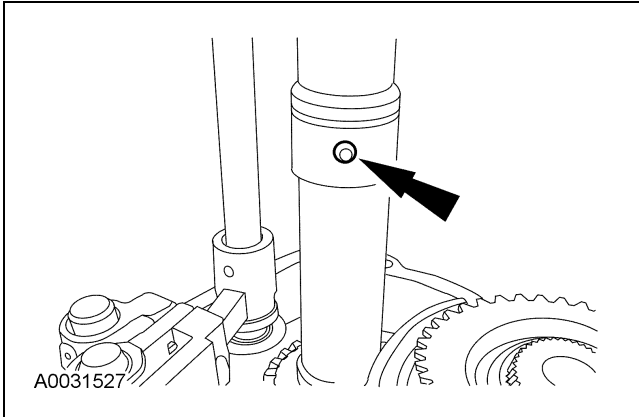

19. Remove and discard the 5th gear synchronizer retaining ring.

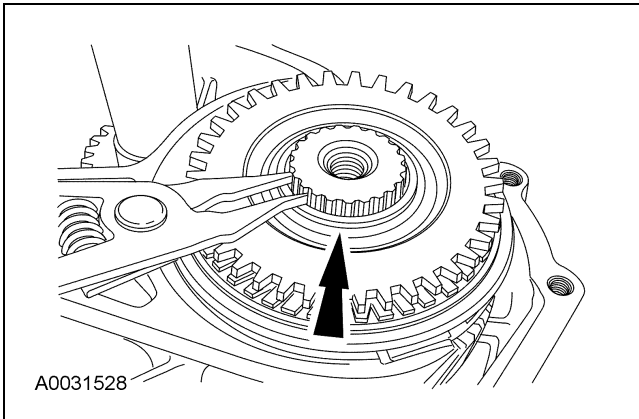

20. Using a 5/32-inch drift and a hammer, remove and discard the pin from the 5th gear shift fork.

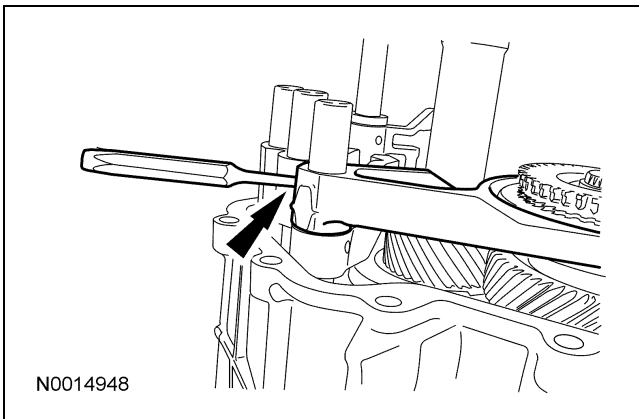

21. **NOTE:** A flat-blade screwdriver may aid in removal.

Using the 2 Jaw Puller, remove the 5th gear shift fork, synchronizer assembly, synchronizer cone and the 5th gear as an assembly.

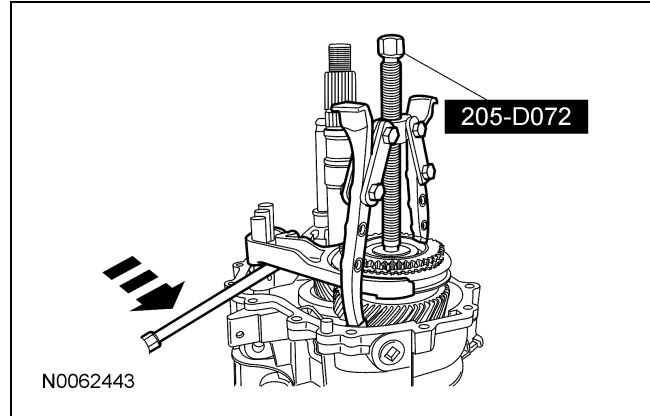

22. Remove the 5th gear clutch cone.

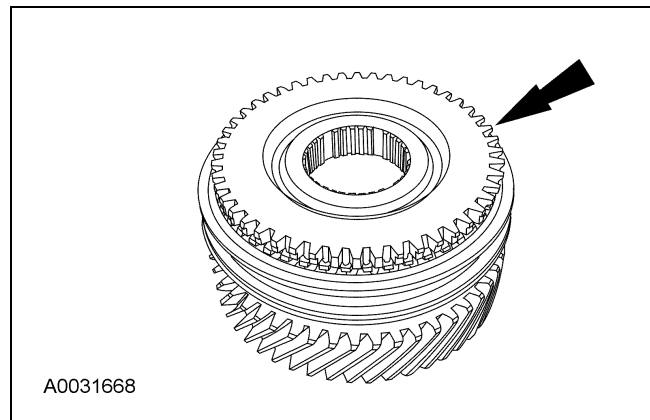

23. Remove the 5th gear synchronizer blocking ring.

- Inspect the blocking ring for wear or damage. Install new blocking rings as necessary.

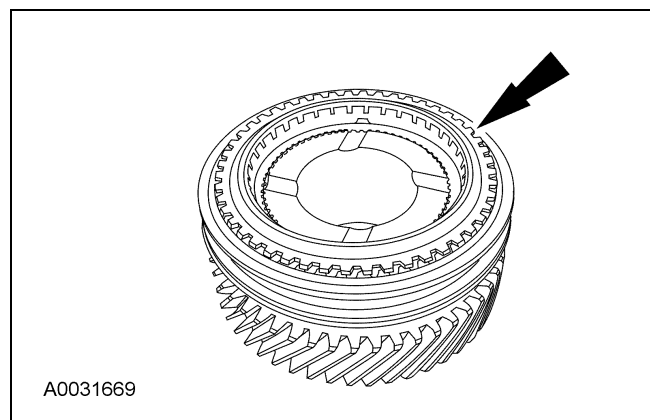

DISASSEMBLY AND ASSEMBLY (Continued)

24. Remove the 5th gear synchronizer sleeve from the synchronizer hub.

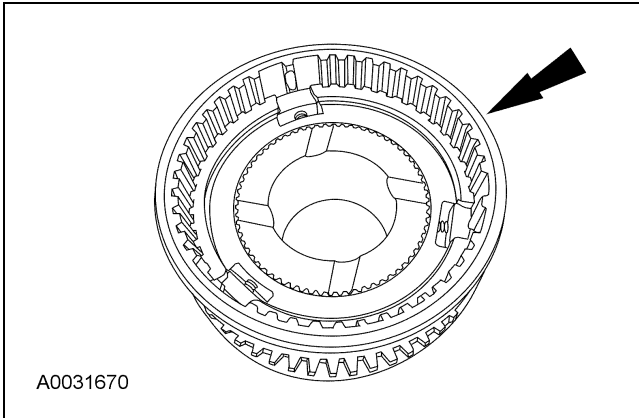

25. Remove the synchronizer inserts and the springs.

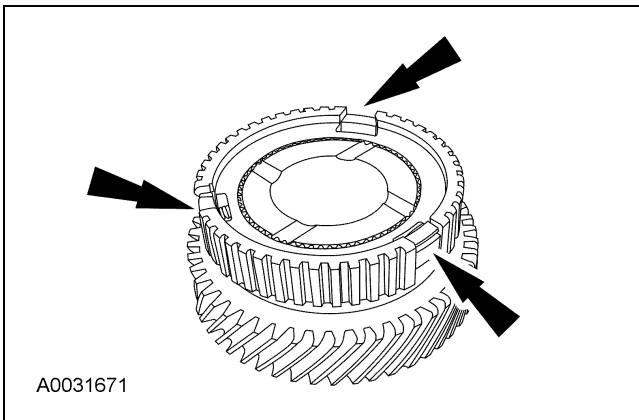

26. Remove the 5th gear needle bearings and the thrust washer.

- Inspect the needle bearings for wear or damage. Install new bearings as necessary.

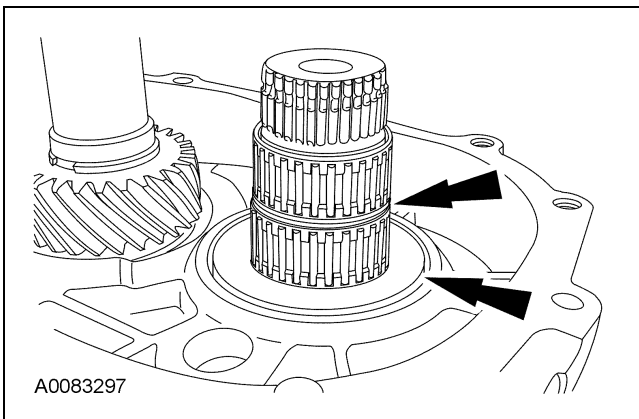

27. Remove the check ball.

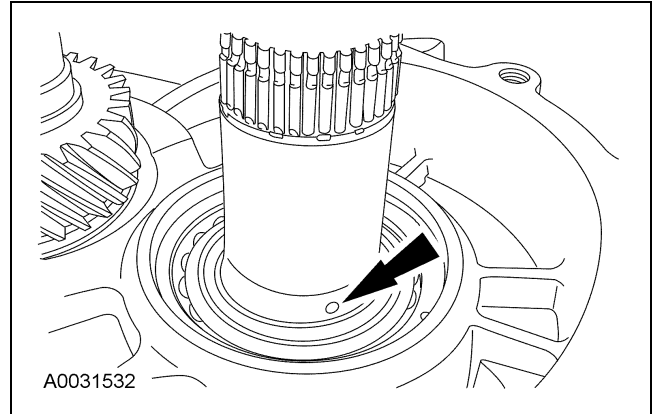

28. Using a 5/32-inch drift and a hammer, drive out the split pin, then remove the 5th/reverse lever fork. Discard the split pin.

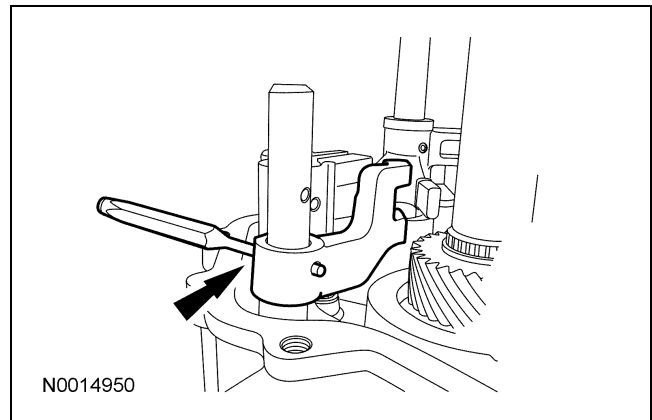

29. Remove the main shift rail.

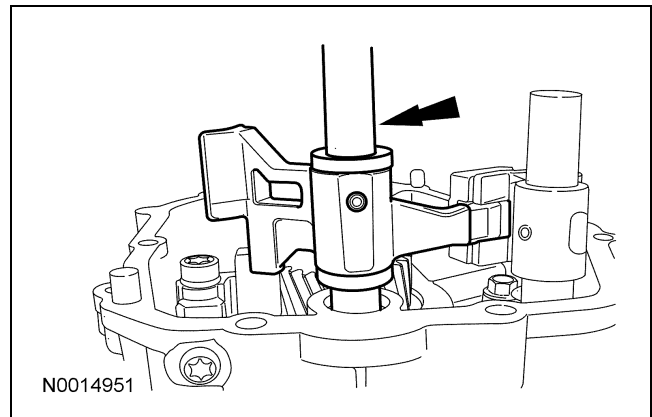

DISASSEMBLY AND ASSEMBLY (Continued)

30. Remove and discard the 2 plastic spacers from the mainshaft rail.

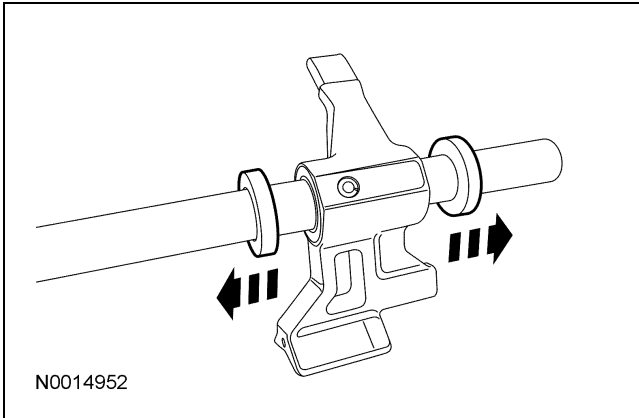

33. Remove the shift interlock plate bolts and the shift interlock plate.

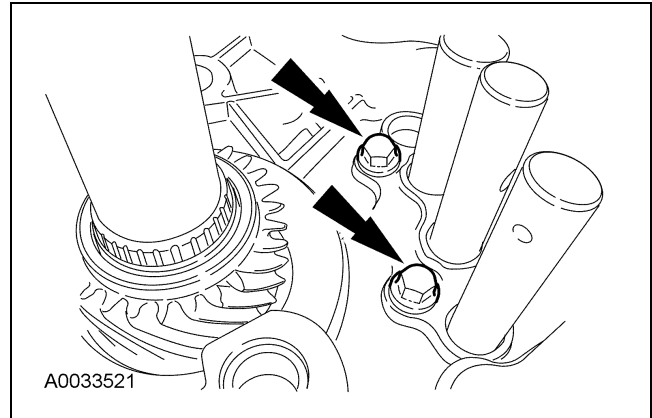

31. Using a 5/32-inch drift and a hammer, drive out the split pin, then remove the 3rd/4th shift finger. Discard the split pin.

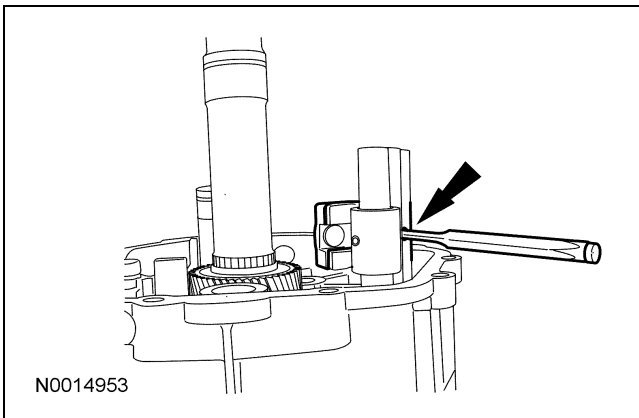

34. Using a magnet, remove the interlock pins.

- One lock pin in the center rail, 2 between the rails.

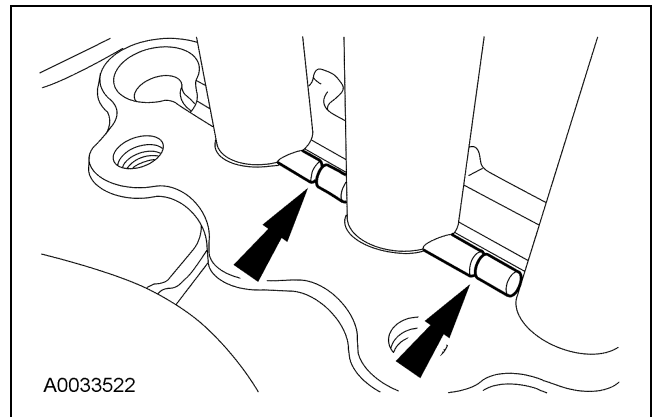

32. Using a 5/32-inch drift and a hammer, drive out the split pin, then remove the 1st/2nd shift finger. Discard the split pin.

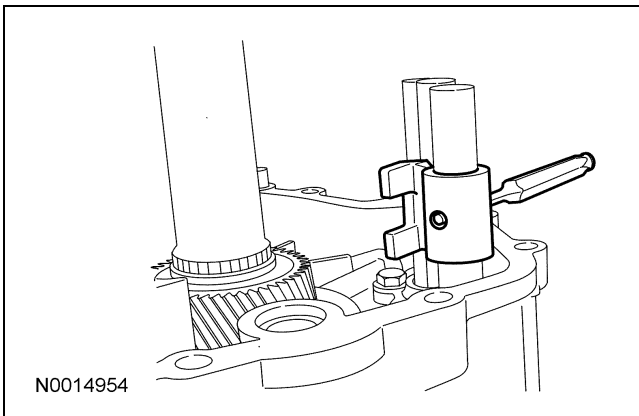

35. Remove the 5th/reverse gear lockout side bolt.

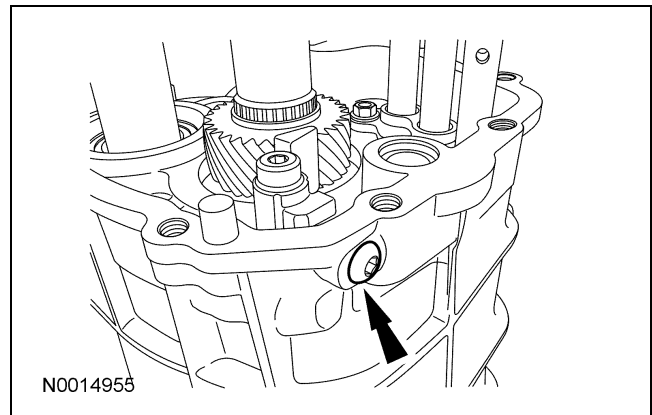

DISASSEMBLY AND ASSEMBLY (Continued)

36. Remove the 5th/reverse gear lockout top bolt, then remove the seal, arm and spring.

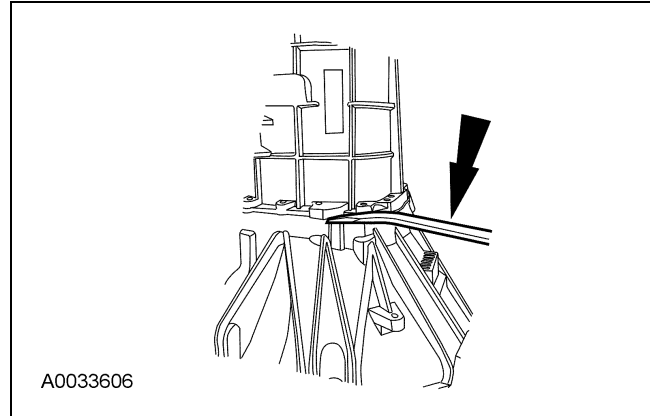
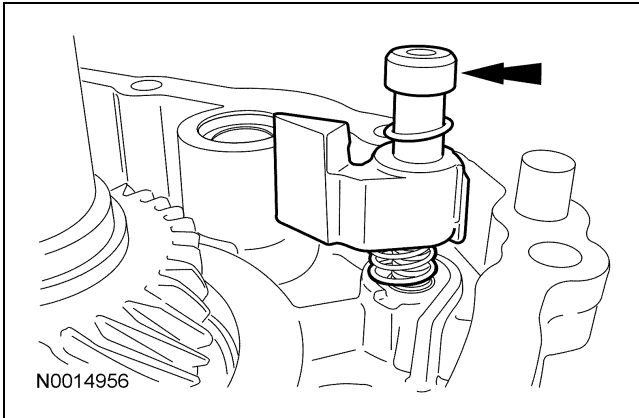

37. **NOTE:** Do not remove all the bolts while in the horizontal position.

Remove the clutch housing-to-transmission main case bolts.

- Rotate the transmission to a horizontal position. Remove 12 bolts, leaving 2 opposing bolts in. Rotate the transmission to a vertical position, then remove the remaining 2 bolts.

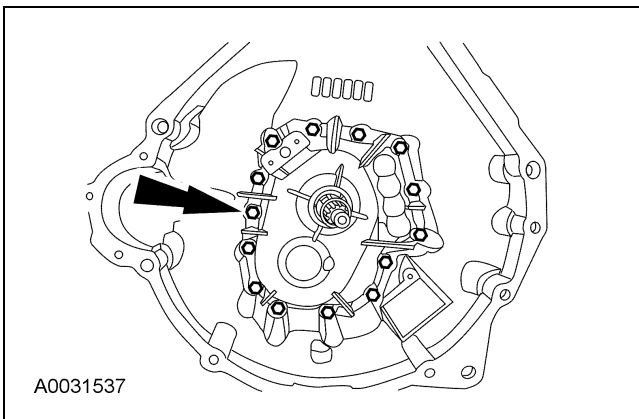

38. Carefully pry the clutch housing from the transmission main case.

39. Remove the transmission main case from the clutch housing.

- The countershaft bearing will remain in the housing. Lightly tap the bearing to remove.
- Inspect the bearing and install a new one if necessary.

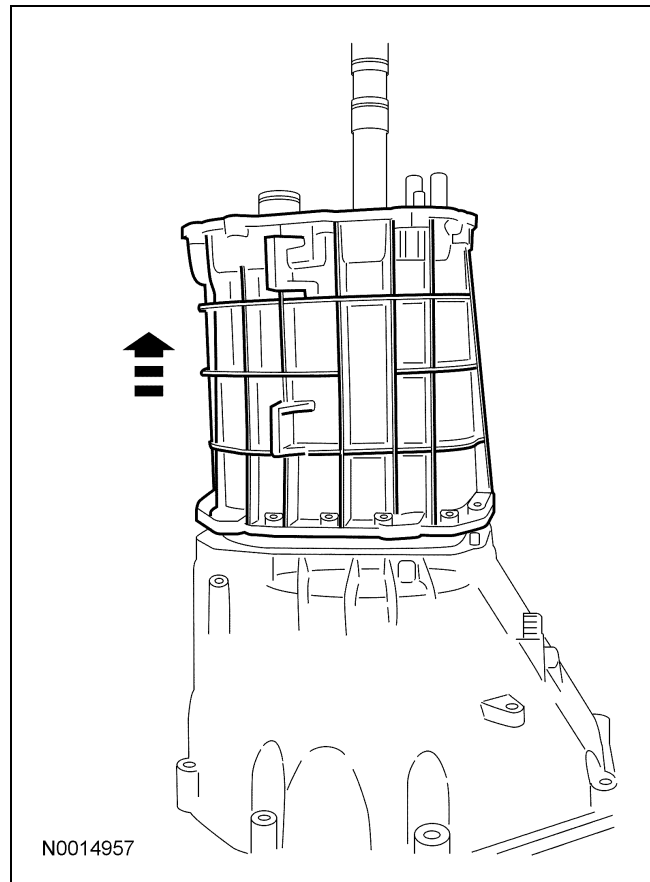

DISASSEMBLY AND ASSEMBLY (Continued)

40. Remove the 3 detent plugs.

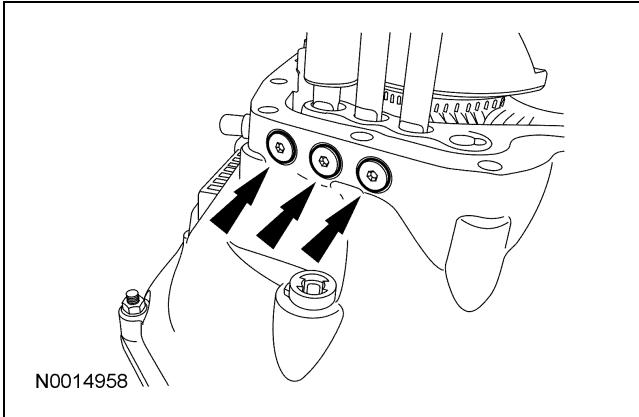

41. Remove the 3 detent springs.

42. Remove the 3 detents.

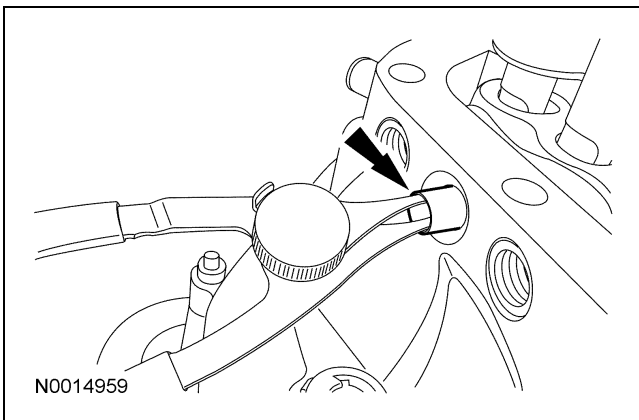

43. Using a jack and a block of wood, lift the mainshaft 13 mm (0.50 in) upward, then tilt the countershaft outward and remove the countershaft.

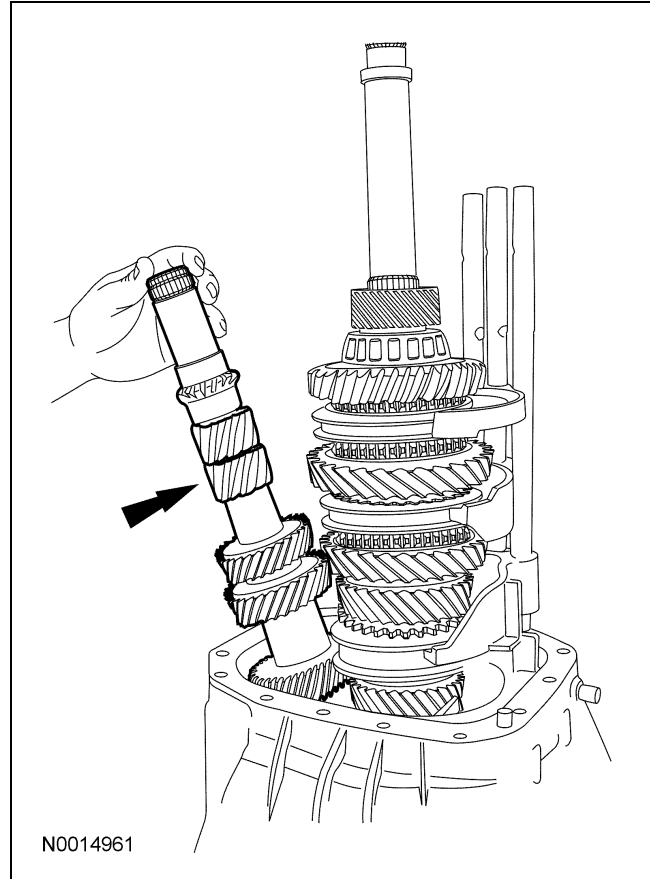

DISASSEMBLY AND ASSEMBLY (Continued)

44. While holding the mainshaft, release the jack and remove the mainshaft and shift assembly.

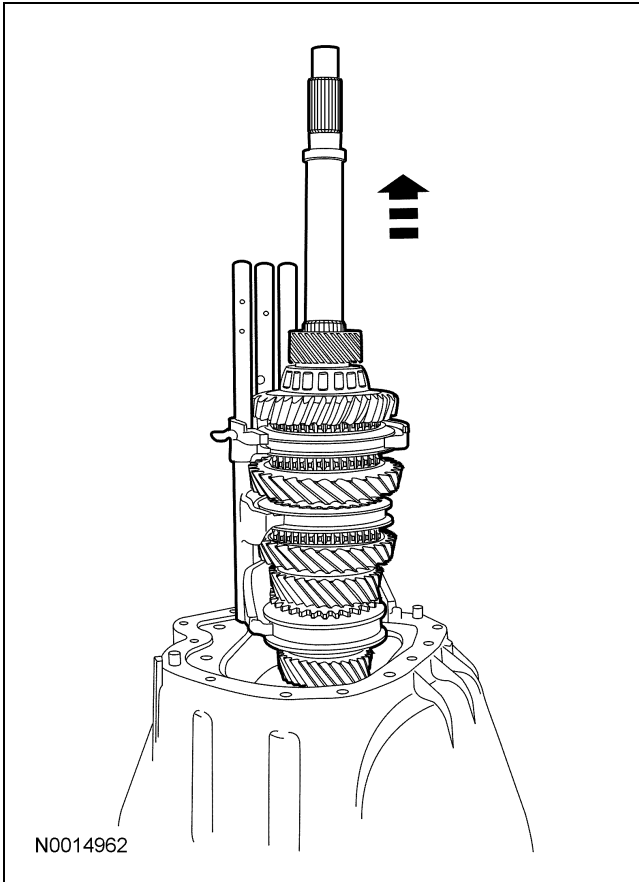

45. Remove the input shaft. For input shaft disassembly, refer to Input Shaft and Bearing in this section.

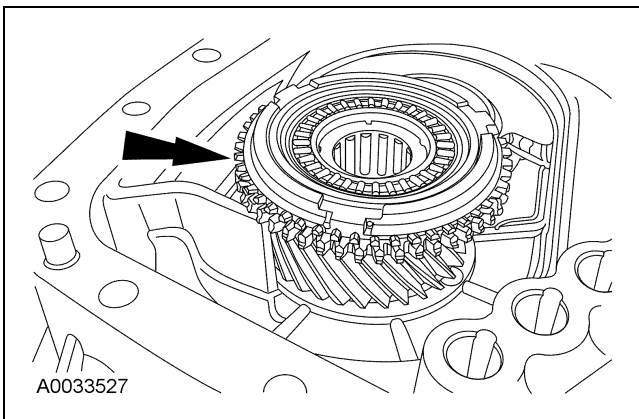

46. Carefully remove the shift rails and shift forks from the main shaft. For gearshift rail and fork disassembly, refer to Gearshift Rail and Fork in this section.

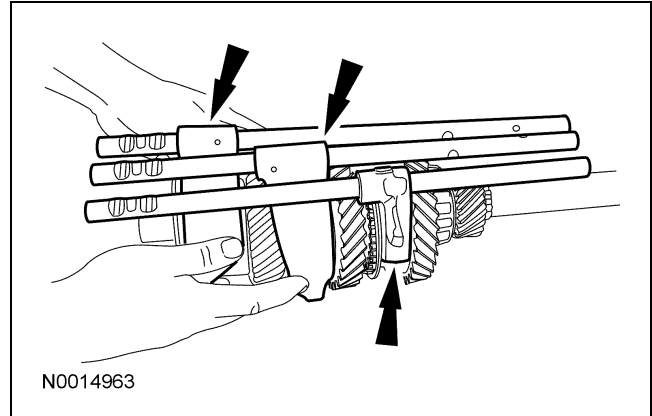

47. Remove the reverse idler shaft bolt. Remove and discard the seal.

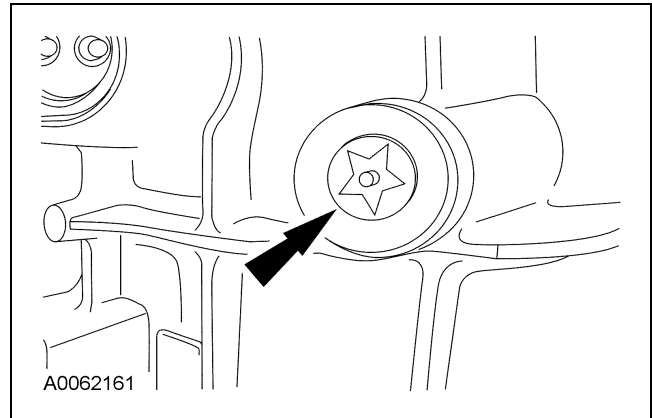

48. Remove the reverse idler gear assembly.

49. Remove the reverse idler gear from the shaft.

- Inspect the gear for wear or damage. Install a new gear as necessary.

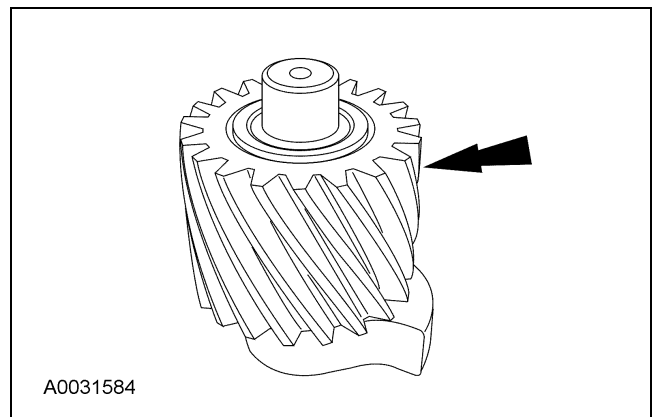

DISASSEMBLY AND ASSEMBLY (Continued)

50. Remove the reverse idler gear bearing.

- Inspect the bearing for wear or damage. Install new bearings as necessary.

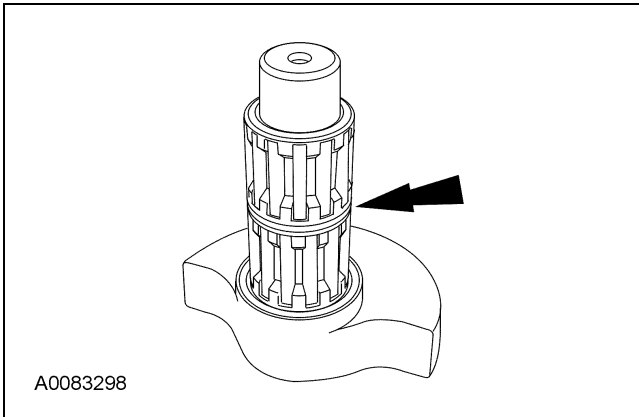

51. Release the clip and remove the clutch slave cylinder connector.

52. Remove the clutch slave cylinder. For additional information, refer to Section 308-02.

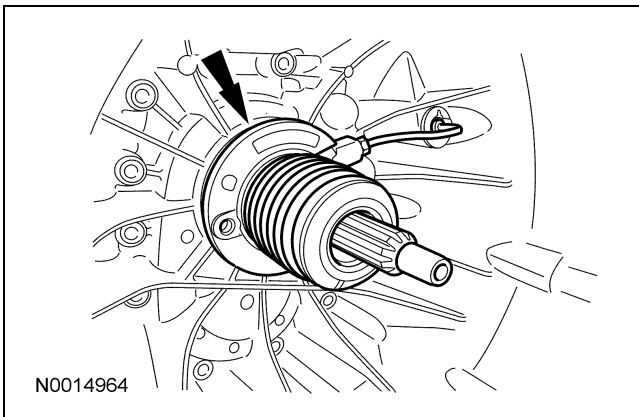

53. Remove and discard the plastic retainer.

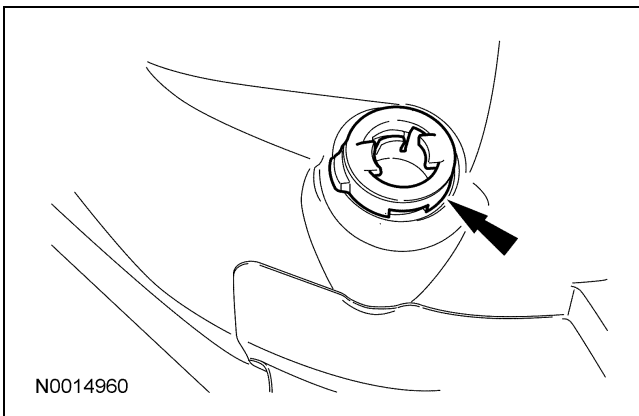

54. Disassemble the clutch housing.

- 1 Remove the countershaft bearing cup and shim.
- 2 Remove the input shaft bearing cup and shim.
- 3 Remove the input shaft seal.
 - Carefully pry out from the inside of the case.

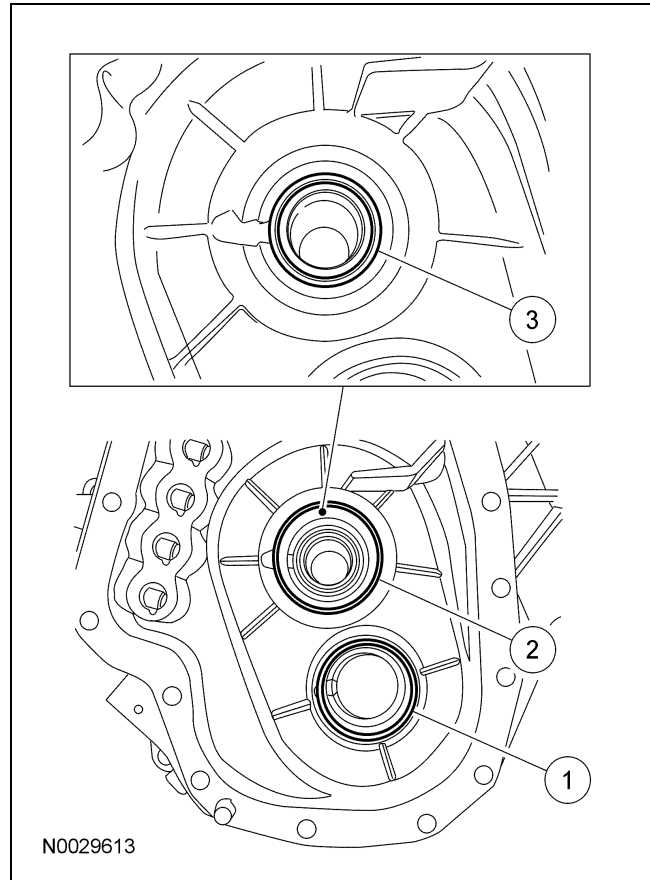

55. Remove the rear countershaft bearing.

- Inspect the bearing for wear or damage. Install new bearings as necessary.

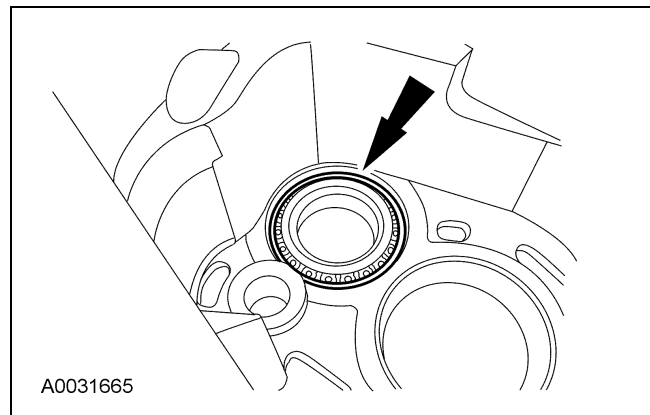

DISASSEMBLY AND ASSEMBLY (Continued)

56. Remove the rear countershaft bearing cup and the rear output shaft bearing cup.
- Inspect the bearing and bearing cup for wear or damage. Install new components as necessary.

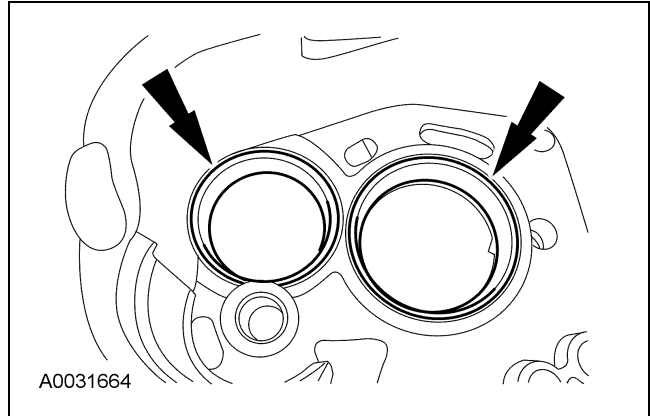

DISASSEMBLY AND ASSEMBLY

Input Shaft and Bearing

Special Tool(s)

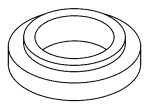
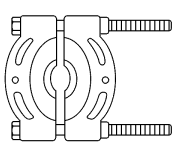
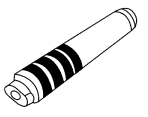
 <p>ST2388-A</p>	<p>Installer, Drive Pinion Bearing Cone 205-011 (T57L-4621-B)</p>
 <p>ST1895-A</p>	<p>Remover, Driver Pinion Bearing Cone 205-D002 (D79L-4621-A) or equivalent</p>
 <p>ST1303-A</p>	<p>Remover/Installer, Bearing Tube 308-024 (T75L-7025-B)</p>

Transmission Internal Components — Input Shaft Disassembled View

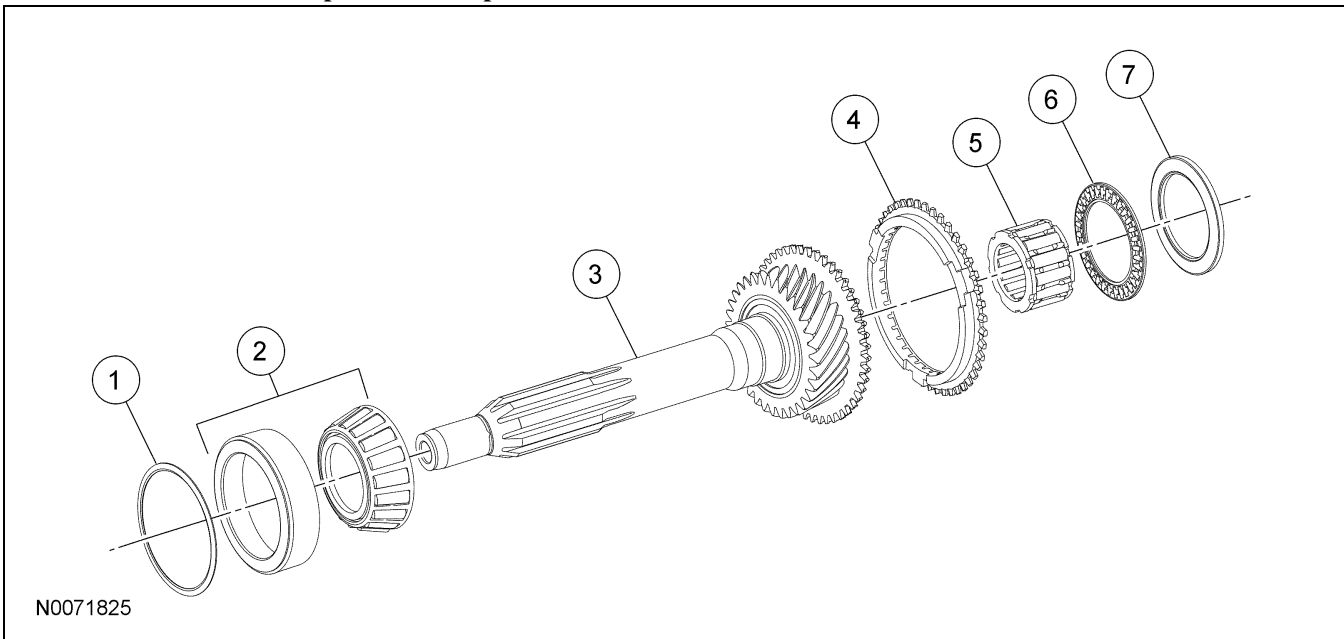

DISASSEMBLY AND ASSEMBLY (Continued)

Item	Part Number	Description
1	7L172	Shim kit
2	7025	Input shaft front bearing and cup assembly
3	7017	Input shaft
4	7107	3rd/4th gear synchronizer blocking ring
5	7025	Input shaft pocket bearing kit
6	7025	Input shaft thrust bearing kit
7	7L271	Input shaft thrust washer (part of spring kit)

Disassembly and Assembly

1. Disassemble the input shaft.
 - 1 Remove the 3rd/4th synchronizer blocking ring.
 - 2 Remove the input shaft thrust washer.
 - 3 Remove the input shaft thrust bearing.
 - 4 Remove the input shaft pocket bearing.
 - Inspect all components for wear or damage. Install new components as necessary.

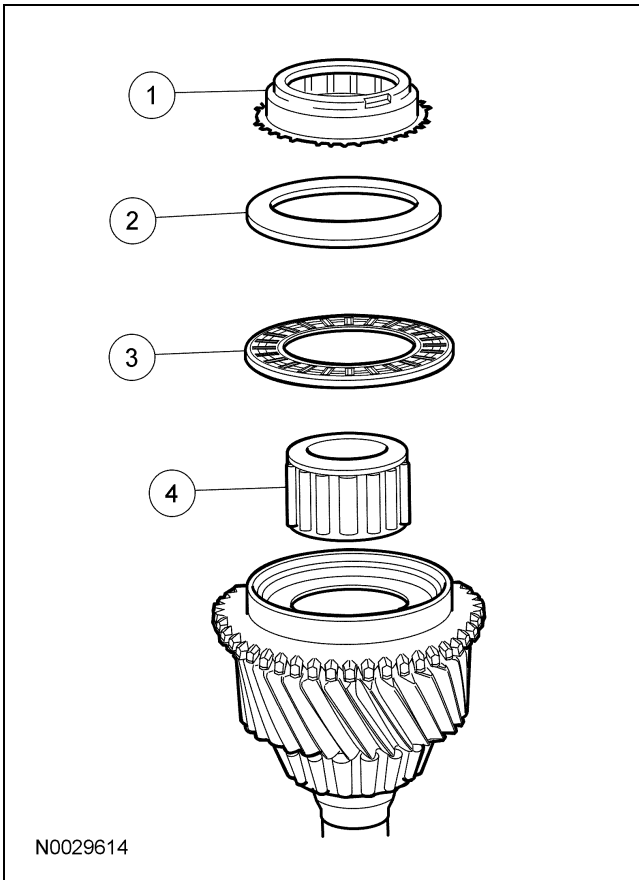

2. Using the Driver Pinion Bearing Cone Remover and a press, remove the input shaft front bearing assembly. Discard the bearing.

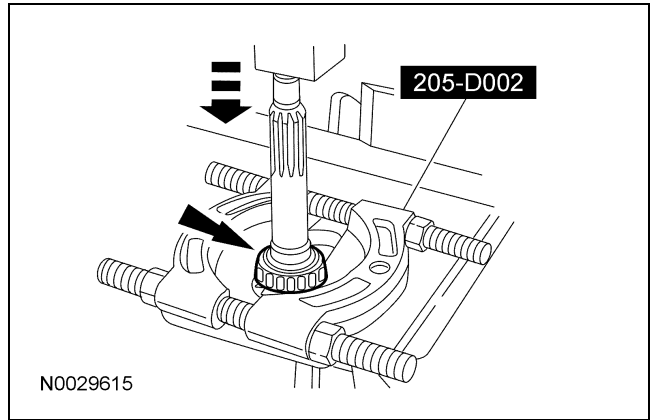

3. Inspect the input shaft, the input shaft pocket bearing, the thrust bearing and the thrust washer for wear or damage. Install new components as necessary.
4. Using the Bearing Tube Remover/Installer and Drive Pinion Bearing Cone Installer and a press, install the new input shaft front bearing.

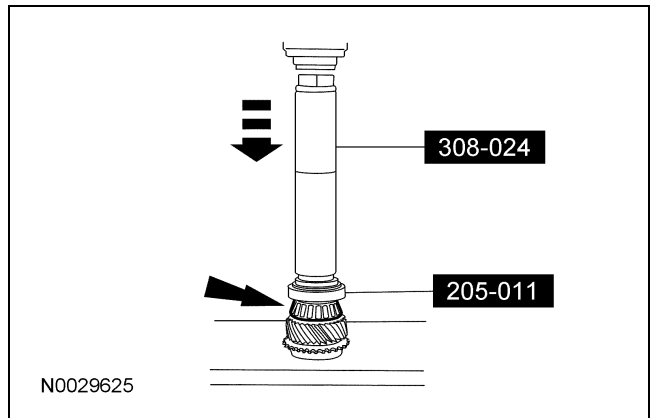

DISASSEMBLY AND ASSEMBLY (Continued)

5. **NOTE:** Lubricate the bearing and bearing race with petroleum jelly.

Install the input shaft pocket bearing, the thrust washer, the thrust bearing and the 3rd/4th synchronizer blocking ring.

DISASSEMBLY AND ASSEMBLY

Output Shaft

Special Tool(s)

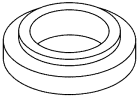
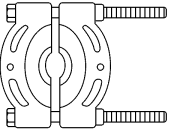
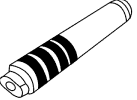
 <p>ST2388-A</p>	<p>Installer, Drive Pinion Bearing Cone 205-011 (T57L-4621-B)</p>
 <p>ST1895-A</p>	<p>Remover, Drive Pinion Bearing Cone 205-D002 (D79L-4621-A) or equivalent</p>
 <p>ST1303-A</p>	<p>Remover/Installer, Bearing Tube 308-025</p>

Material

Item	Specification
<p>MERCON® V Automatic Transmission Fluid XT-5-QM (or XT-5-QMC) (US); CXT-5-LM12 (Canada)</p>	<p>MERCON® V</p>

DISASSEMBLY AND ASSEMBLY (Continued)

Transmission Internal Components — Output Shaft Disassembled View

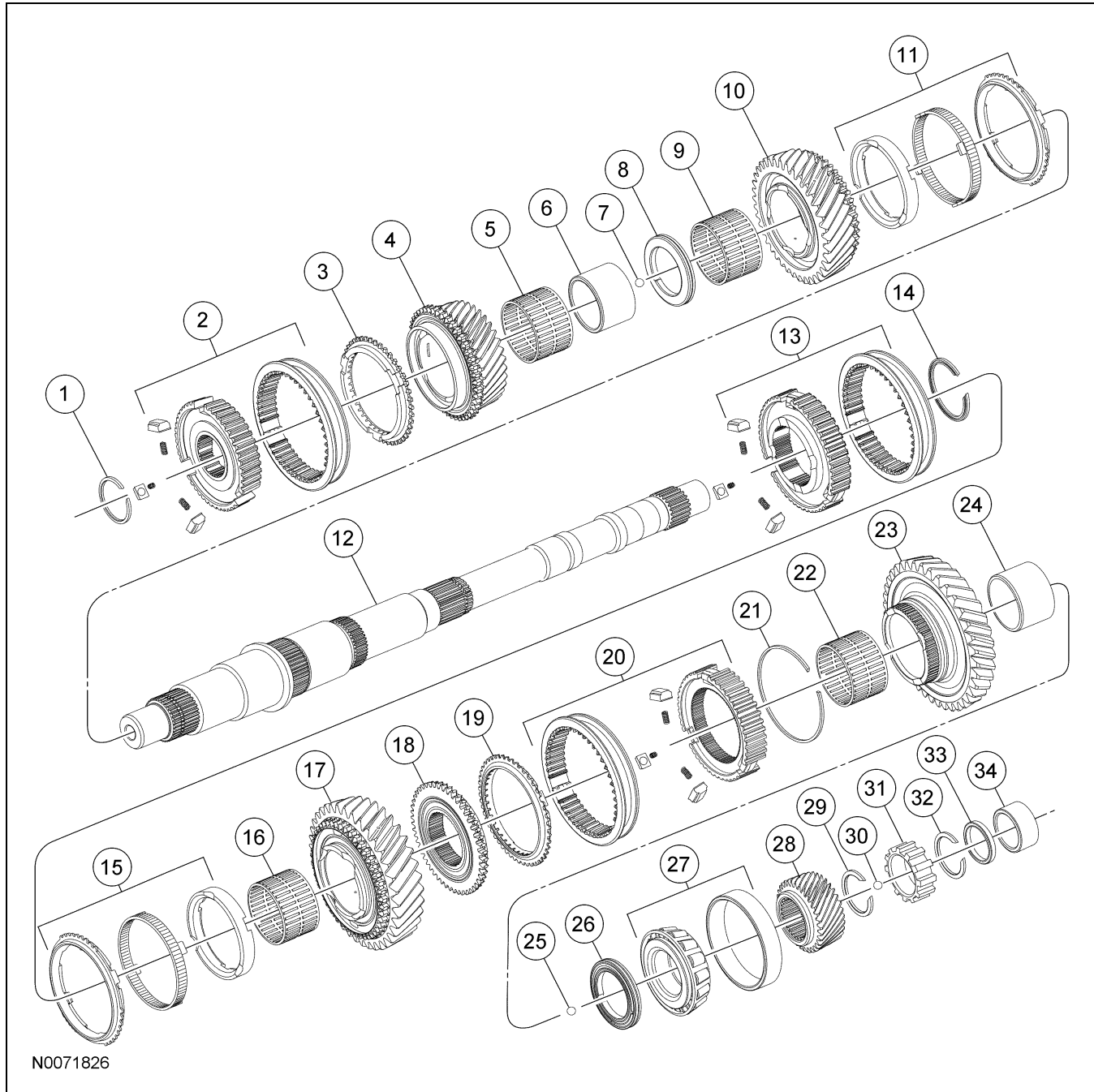

N0071826

Item	Part Number	Description
1	7L271	Retaining ring (part of spring kit)
2	7124	3rd/4th gear synchronizer assembly
3	7107	3rd/4th gear synchronizer blocking ring
4	7B340	3rd gear
5	7025	3rd gear needle bearing kit
6	7N193	3rd gear bushing

(Continued)

Item	Part Number	Description
7	7L271	Check ball (part of spring kit)
8	7L271	Thrust washer (part of spring kit)
9	7025	2nd gear needle bearing kit
10	7102	2nd gear
11	7107	1st/2nd gear synchronizer cones assembly (3 piece)
12	7061	Output shaft

(Continued)

DISASSEMBLY AND ASSEMBLY (Continued)

Item	Part Number	Description
13	7124	1st/2nd gear synchronizer assembly
14	7L271	Retaining ring (part of spring kit)
15	7107	1st/2nd gear synchronizer cones assembly (3 piece)
16	7025	1st gear needle bearing
17	7100	1st gear
18	7124	Reverse clutch cone
19	7107	Reverse gear synchronizer blocking ring
20	7124	Reverse gear synchronizer assembly
21	7124	Retaining ring
22	7025	Reverse needle bearing
23	7124	Reverse driven gear
24	7N193	Reverse gear bushing
25	7L271	Check ball (part of spring kit)
26	7L271	Selector gate (part of spring kit)
27	7025	Main shaft rear bearing and cup
28	7K316	Main shaft 5th gear
29	7L271	Retaining ring (part of spring kit)
30	7L271	Check ball (part of spring kit)
31	7H150	Output Shaft Speed (OSS) sensor ring
32	7L271	Retaining ring (part of spring kit)
33	7L271	Spacer (part of spring kit)
34	7025	Extension housing bearing bushing

Disassembly

1. Remove the retaining ring above 5th gear.

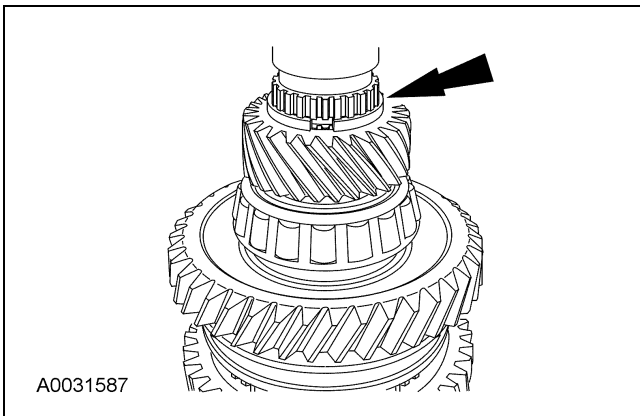

2. **NOTICE:** Hand-tighten the Drive Pinion Bearing Cone Remover to prevent gear damage.

NOTICE: Support the output shaft while using the press to prevent damage to the shaft or gears.

Using the Drive Pinion Bearing Cone Remover, press 5th gear, the spacer, the output shaft bearing and reverse gear from the output shaft.

- Discard the output shaft bearing.

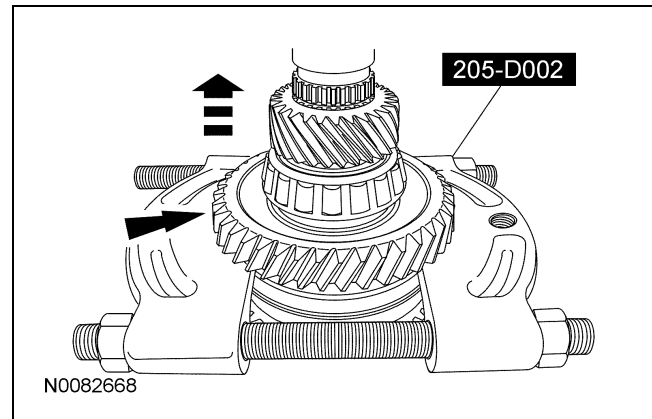

3. Remove reverse gear needle bearing.

- Inspect the needle bearing for wear or damage. Install a new needle bearing as necessary.

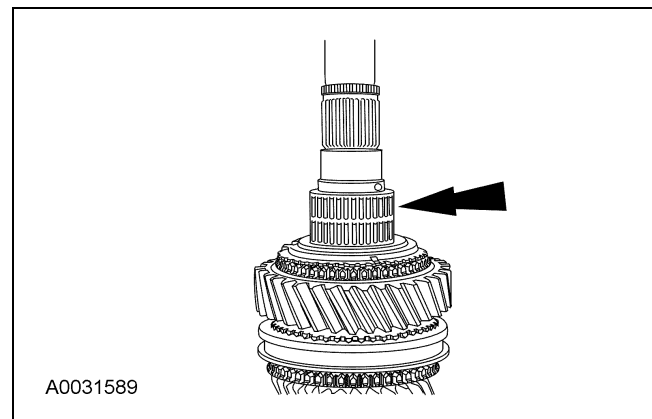

DISASSEMBLY AND ASSEMBLY (Continued)

4. Remove the check ball and the blocking ring.
 - Inspect the blocking ring for wear or damage. Install new blocking rings as necessary.

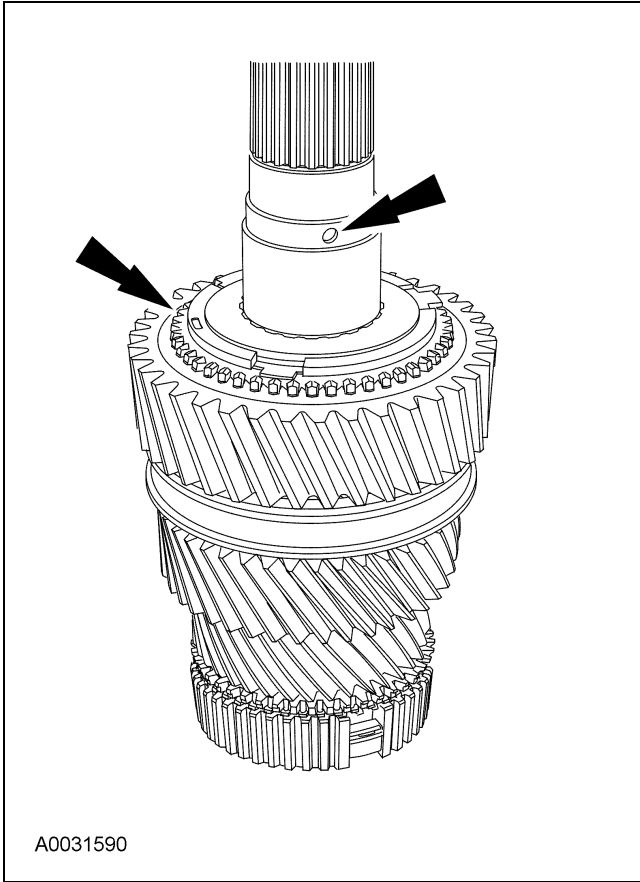

6. Remove the 1st gear needle bearing.
 - Inspect the needle bearing for wear or damage. Install a new needle bearing as necessary.

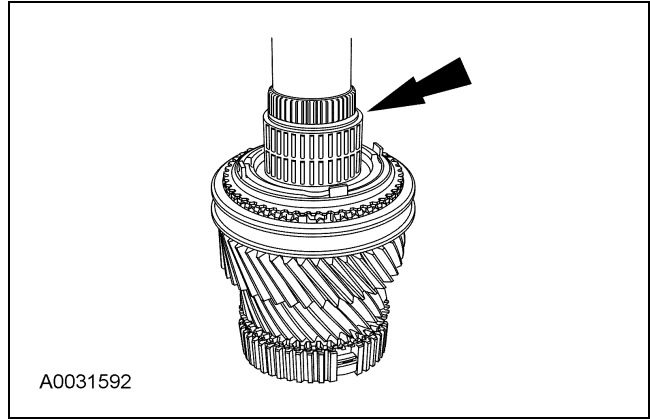

5. **NOTE:** Install the Drive Pinion Bearing Cone Remover with the flat side facing 1st gear. Using the Drive Pinion Bearing Cone Remover, press the bearing spacer, the reverse gear synchronizer cone and 1st gear from the output shaft.

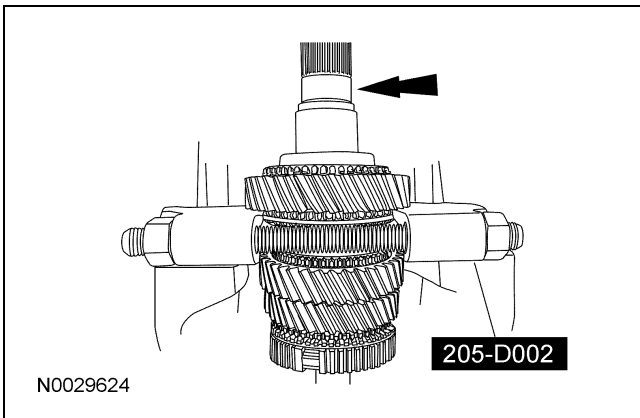

7. Remove the 1st gear synchronizer inner cone, the 1st gear synchronizer outer cone and the 1st gear synchronizer blocking ring.
 - Inspect all components for wear or damage. Install new components as necessary.

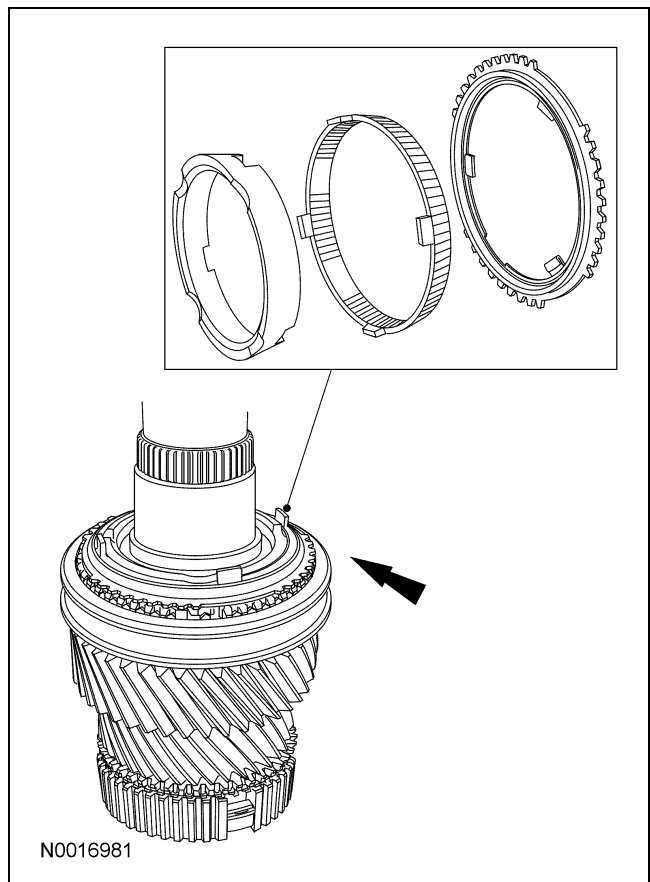

DISASSEMBLY AND ASSEMBLY (Continued)

8. **NOTE:** Reposition the output shaft on the press with the input shaft end facing upward.
Remove and discard the retaining ring.

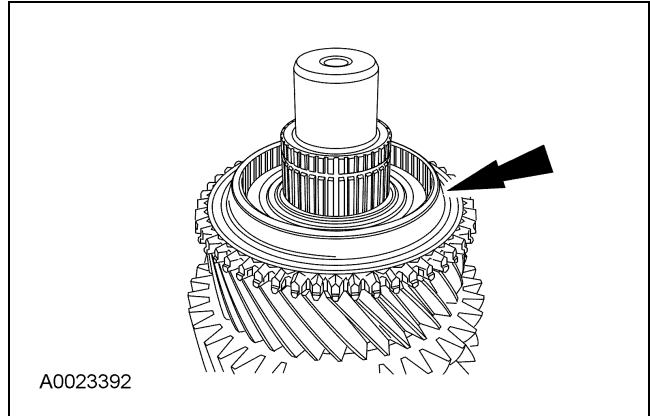
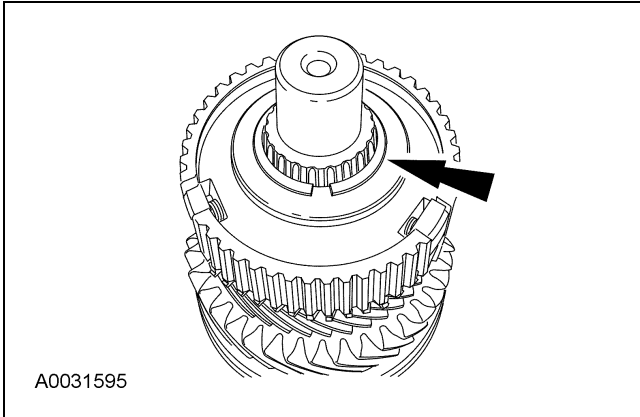

9. Remove the 3rd/4th synchronizer hub.

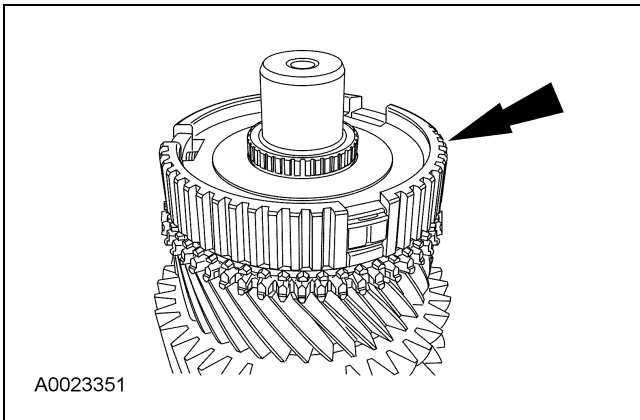

12. **NOTE:** Inspect the needle bearing for wear or damage. Install a new needle bearing as necessary.

Remove the 3rd gear needle bearing.

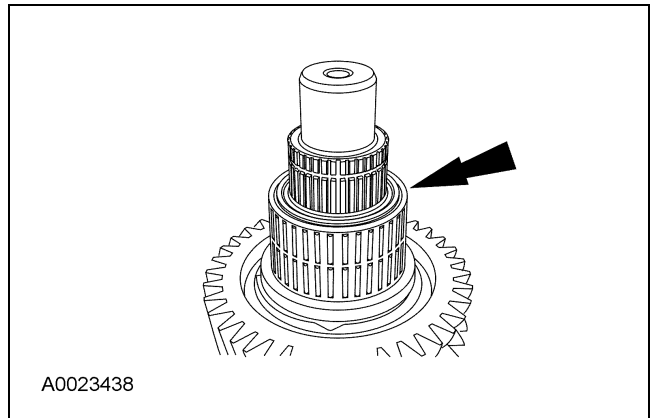

10. Remove the 3rd/4th blocking ring.

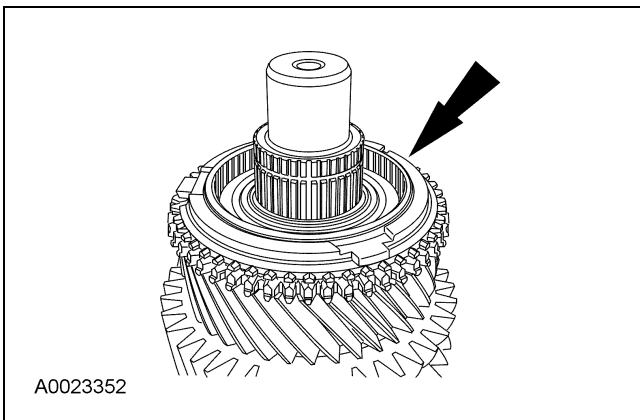

13. **NOTE:** Install the Drive Pinion Bearing Cone Remover behind 2nd gear with the flat side of the tool facing 2nd gear.

Using the Drive Pinion Bearing Cone Remover, remove the spacer, 2nd gear thrust washer and 2nd gear.

- Inspect the gear for wear or damage. Install a new gear as necessary.

11. Remove the 3rd gear.

- Inspect the gear for wear or damage. Install a new gear as necessary.

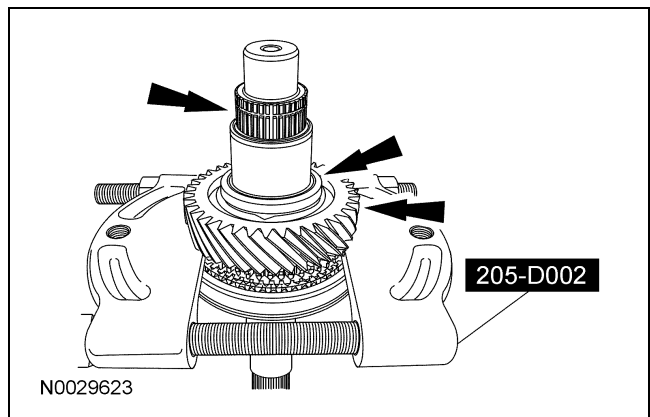

DISASSEMBLY AND ASSEMBLY (Continued)

14. Remove the check ball and 2nd gear needle bearing.
- Inspect the needle bearing for wear or damage. Install a new needle bearing as necessary.

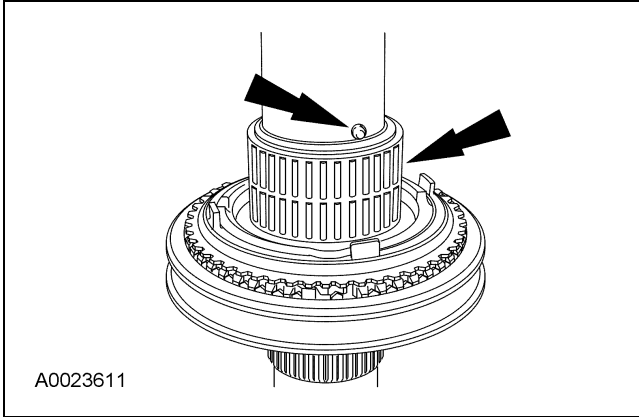

15. Remove the 2nd gear synchronizer inner cone, 2nd gear synchronizer outer cone and the 2nd gear synchronizer blocking ring.
- Inspect all components for wear or damage. Install new components as necessary.

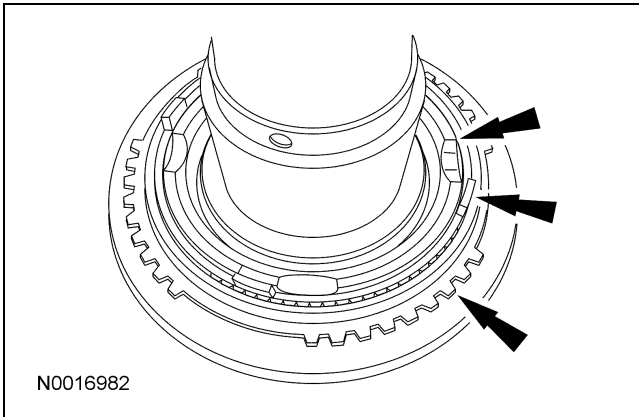

16. Remove and discard the snap ring, then using the Drive Pinion Bearing Cone Remover, press off the 1st/2nd gear synchronizer.

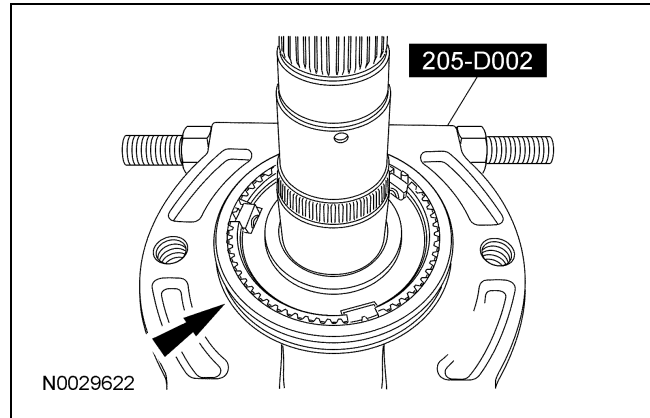
**Assembly**

1. Carry out the following before reassembling:
 - Inspect the gears for broken or cracked teeth. Check for unusual wear patterns.
 - Inspect the thrust washers for face wear, cracks, scoring and for signs of heat damage.
 - Inspect the bearings, bearing cups and the synchronizers for wear or damage.
 - Inspect the output shaft for scoring, wear or damaged splines. Install new components as necessary.
 - Always install new retaining rings.
2. Lubricate all components with the recommended transmission fluid when reassembling.

DISASSEMBLY AND ASSEMBLY (Continued)

3. **NOTE:** Install the synchronizer assembly with the deeper center flange of the synchronizer hub facing toward the rear of the output shaft.

NOTE: If installing the original synchronizer assembly, make sure the index marks made during disassembly are aligned.

NOTE: It may be necessary to press the hub into position on the shaft.

NOTE: Do not overextend the retaining ring. A damaged or overextended retaining ring will not allow 1st gear to fully seat.

Position the output shaft with the output end facing upward. Install the 1st/2nd synchronizer assembly on the output shaft, then install a new retaining ring.

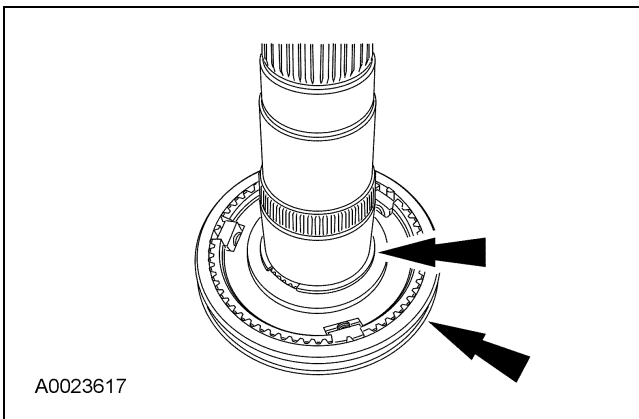
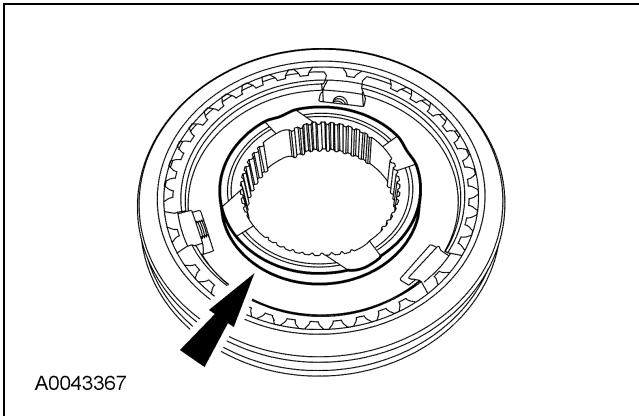

4. **NOTE:** Align the blocking ring tabs with the synchronizer assembly.
Install the 1st gear synchronizer blocking ring.

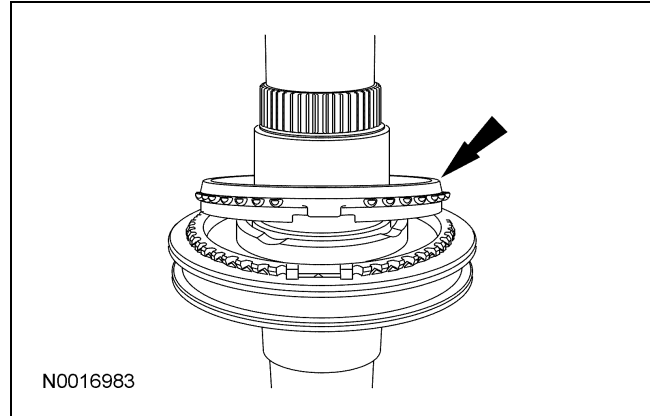

5. Install the outer 1st gear synchronizer cone.

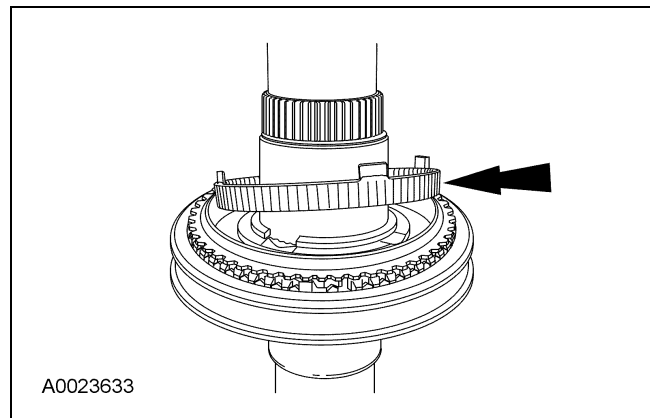

6. Install the inner 1st gear synchronizer cone.
Rotate the inner cone until it is seated.

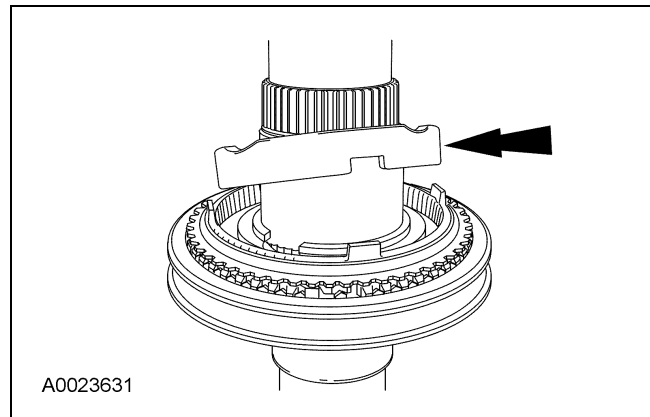

DISASSEMBLY AND ASSEMBLY (Continued)

- 7. **NOTE:** Apply petroleum jelly to the bearing.
Install the 1st gear needle bearing.

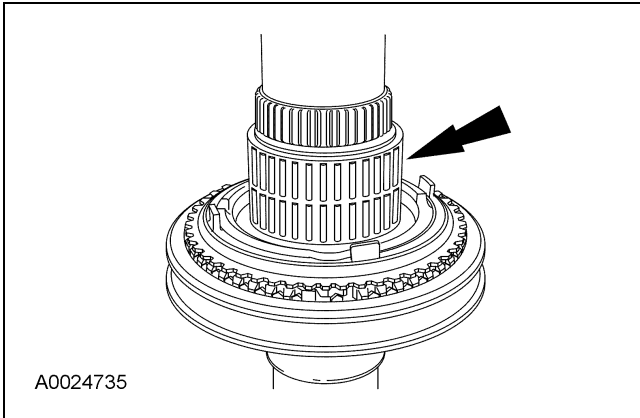

- 8. **NOTE:** First gear is 127 mm (5 in) in diameter.
NOTE: Rotate the gear to align the gear slots with the inner cone tabs.
NOTE: Make sure that the gear fits over the retaining ring.
Install 1st gear.

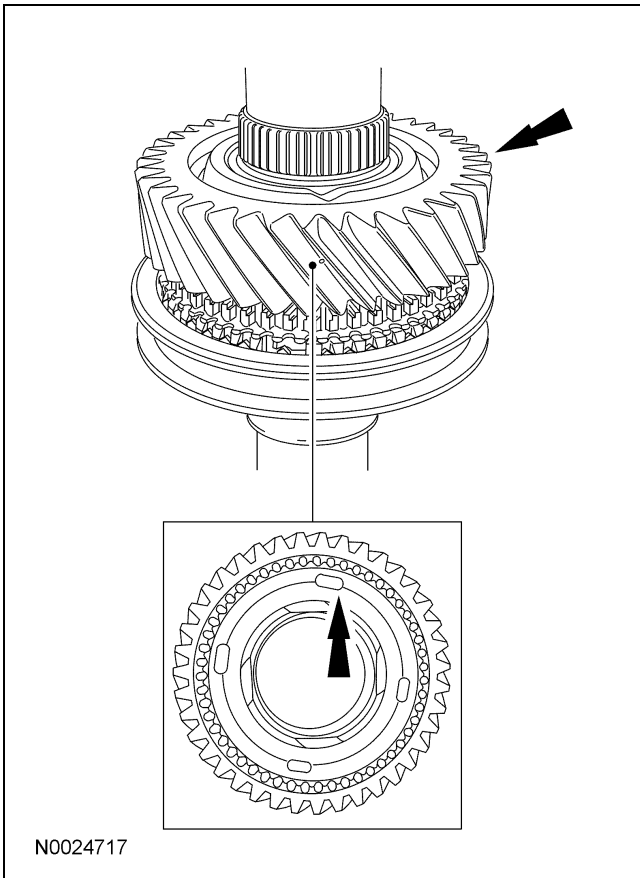

- 9. Install the reverse synchronizer cone.

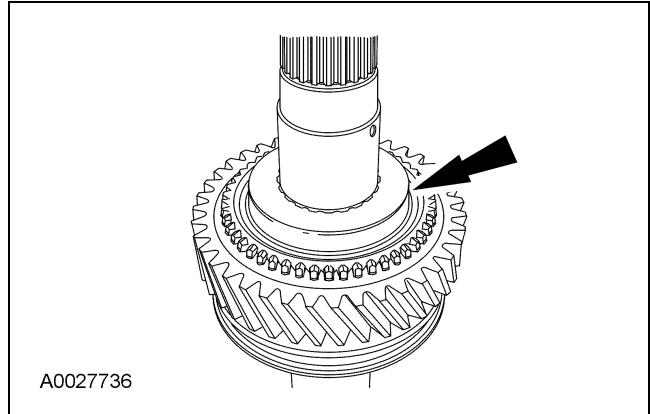

- 10. Install the reverse gear blocking ring.

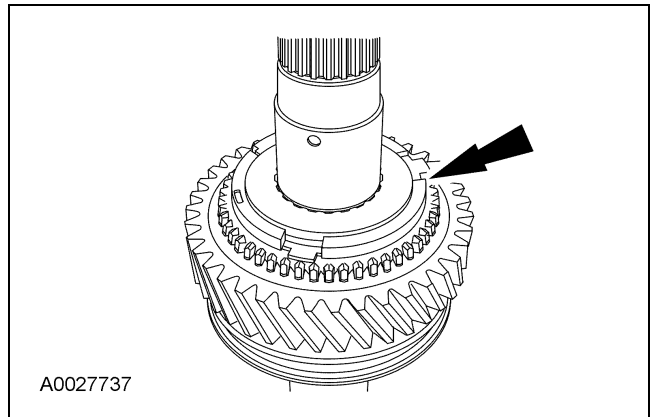

DISASSEMBLY AND ASSEMBLY (Continued)

11. Using the Bearing Tube Remover/Installer and Drive Pinion Cone Installer, install the reverse gear bearing spacer.

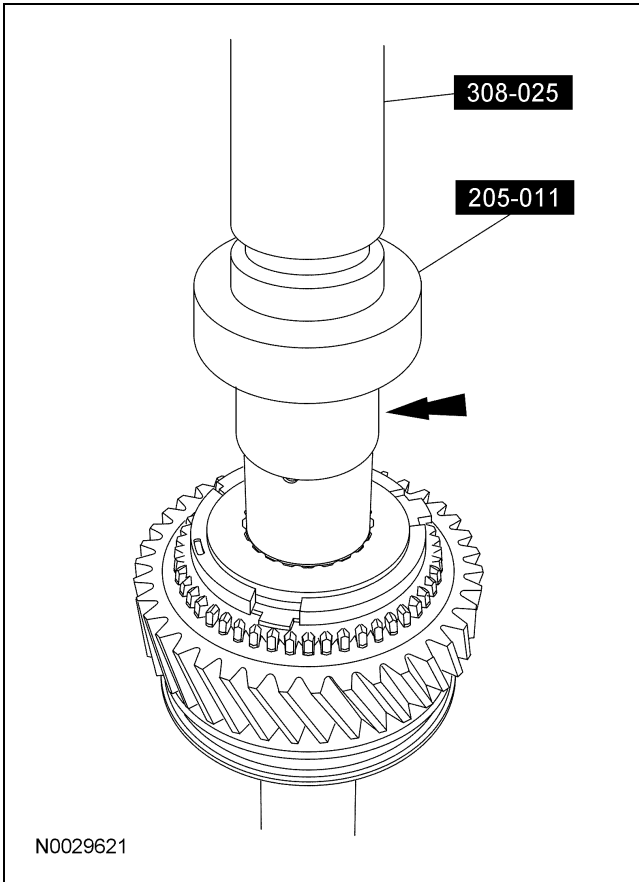

12. Install the reverse gear needle bearing.
- Apply petroleum jelly to the bearing.

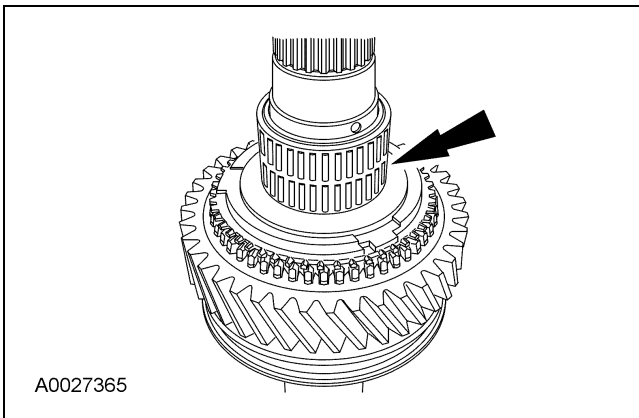

13. Install the reverse gear synchronizer assembly.

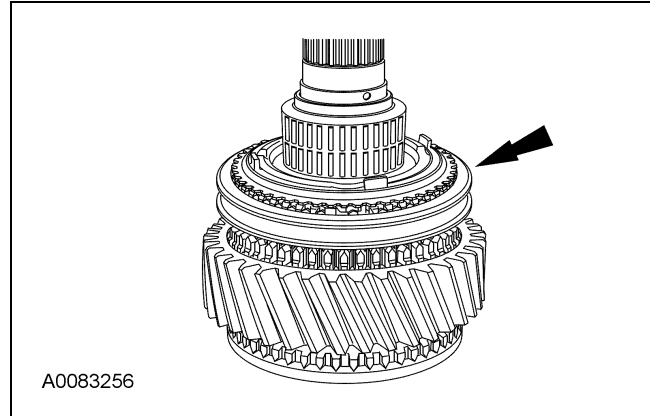

14. **NOTE:** Rotate the gear to align the gear slots with the inner cone tabs.

NOTE: Make sure the clutching teeth on the gear snap inside the sliding sleeve and the sliding sleeve is against the gear.

NOTE: Function the synchronizer sleeve through the 2 positions to make sure of normal function.

Install reverse gear.

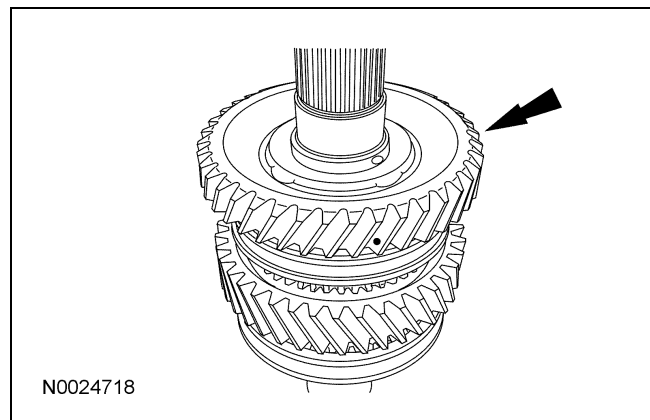

15. **NOTE:** Use petroleum jelly to hold the check ball in place.

Install the check ball.

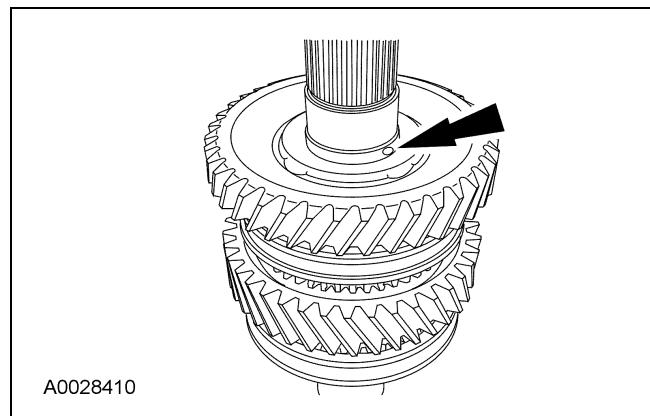

DISASSEMBLY AND ASSEMBLY (Continued)

16. Install the thrust washer. Be sure to align the slot in the washer with the check ball.

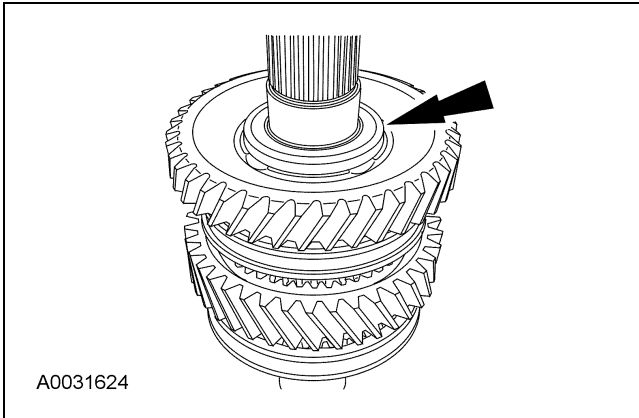

17. **NOTE:** The flatside of 5th gear faces the output shaft end.

Install the rear output shaft bearing, then 5th gear. Using the Bearing Tube Remover/Installer, press both the bearing and gear into place.

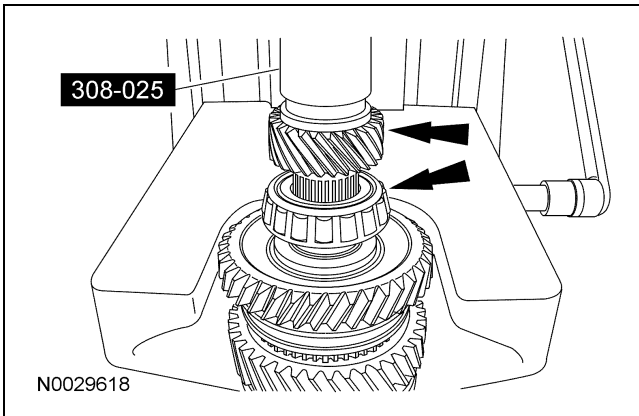

18. **NOTE:** Do not overextend the retaining ring.
Install a new retaining ring.

19. Reposition the output shaft with the input end facing upward.

20. Install the 2nd gear synchronizer blocking ring. Rotate the blocking ring until seated.

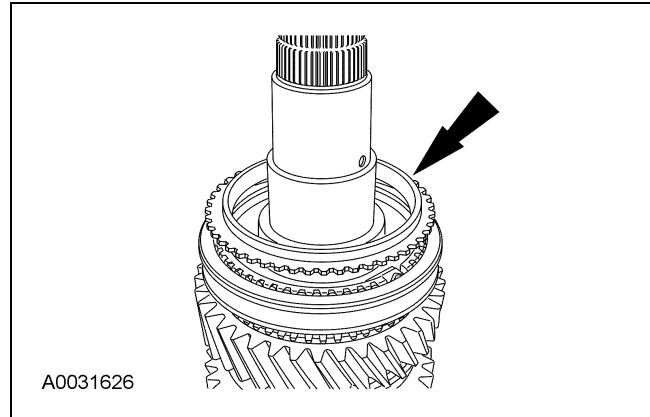

21. Install the 2nd gear synchronizer outer cone and the second gear synchronizer inner cone.

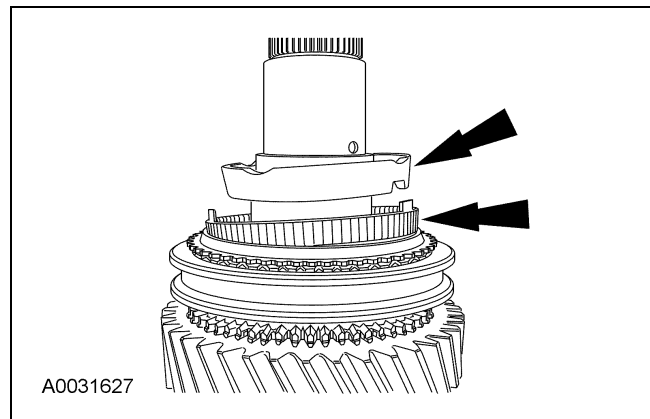

DISASSEMBLY AND ASSEMBLY (Continued)

22. **NOTE:** Apply petroleum jelly to the bearing.
Install the 2nd gear bearing.

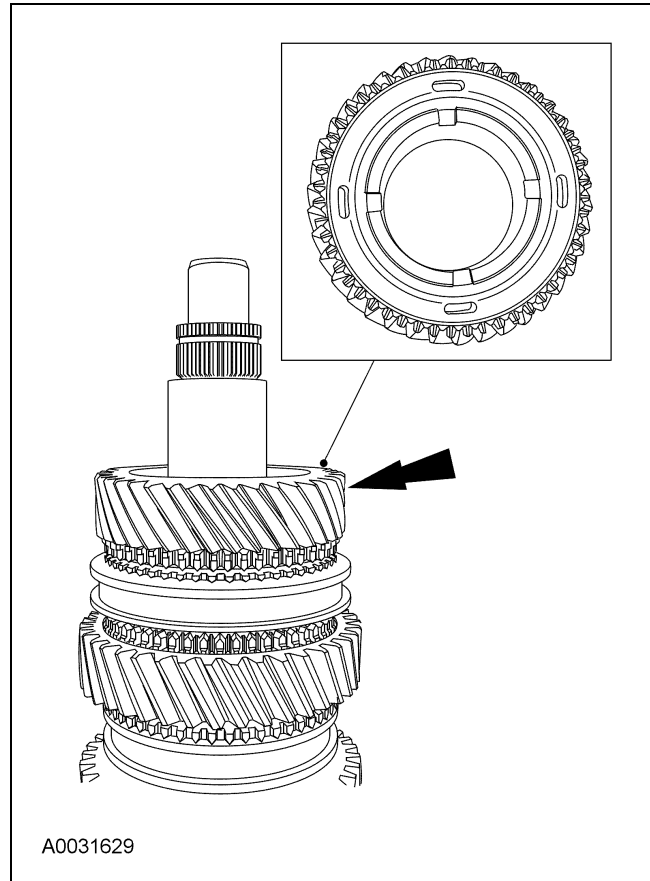
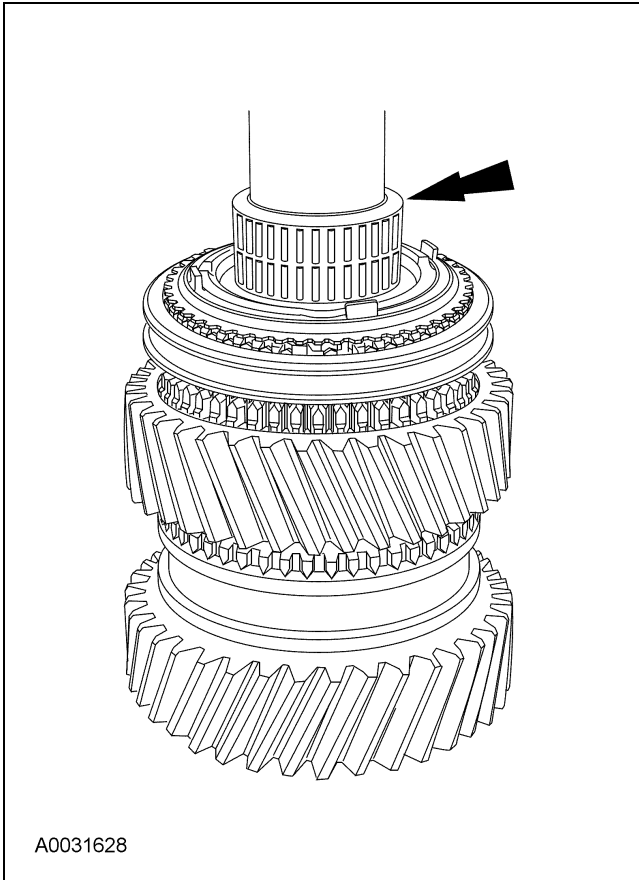

23. **NOTE:** Rotate the gear to align the gear slots with the inner cone tabs.
Install 2nd gear.

DISASSEMBLY AND ASSEMBLY (Continued)

24. **NOTE:** Use petroleum jelly to hold the check ball in place.

Install the check ball.

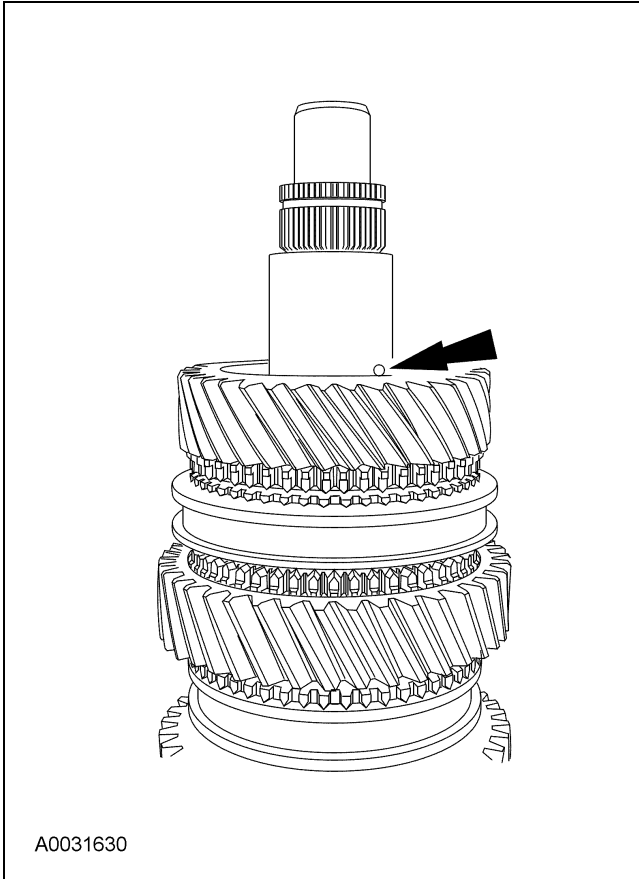

25. Install the thrust washer. Be sure to align the slot in the washer with the check ball.

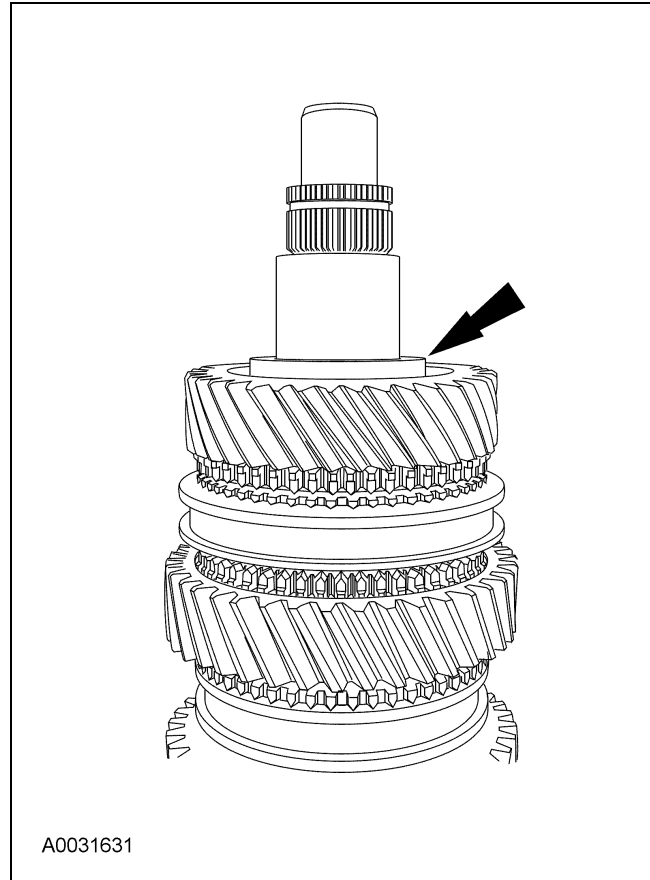

DISASSEMBLY AND ASSEMBLY (Continued)

26. Press the bearing spacer onto the output shaft.

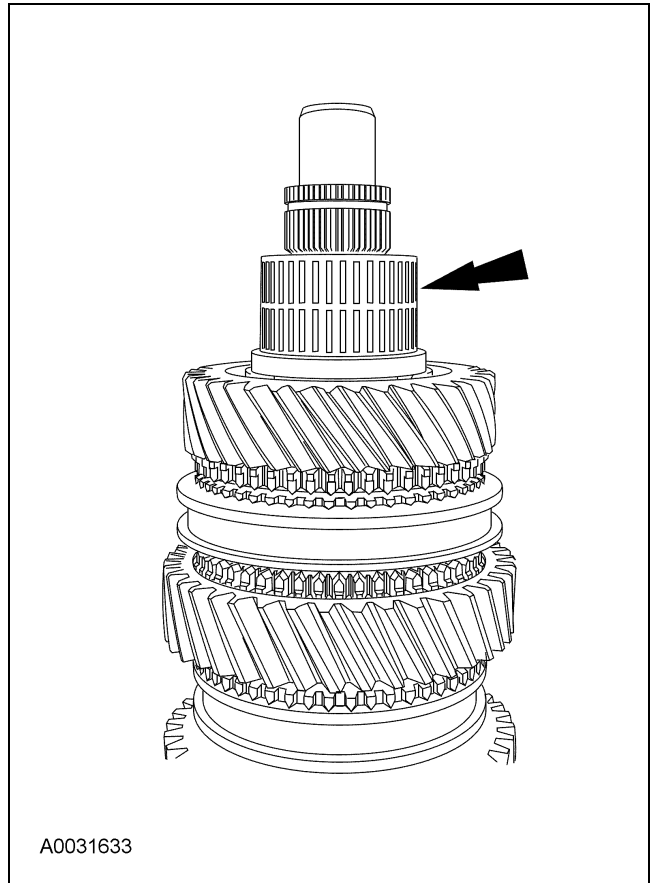
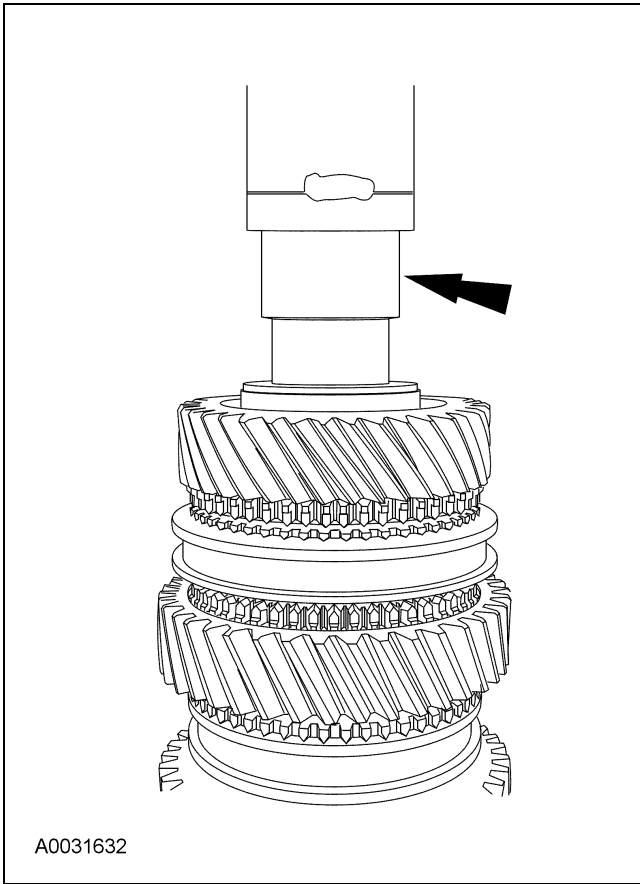

27. **NOTE:** Apply petroleum jelly to the bearing.
Install the 3rd gear bearing.

DISASSEMBLY AND ASSEMBLY (Continued)

28. Install 3rd gear.

29. Install the 3rd gear synchronizer blocking ring.

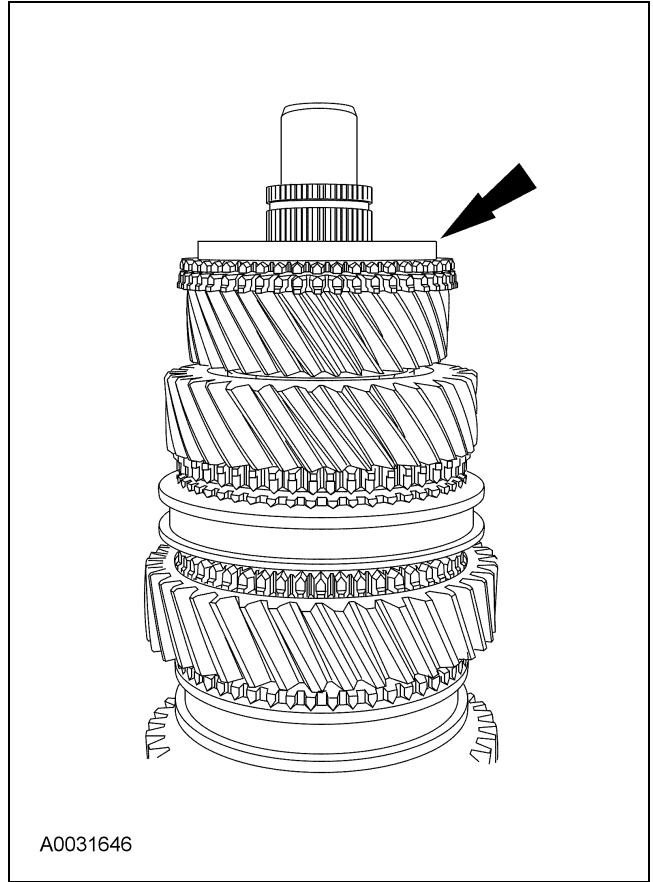
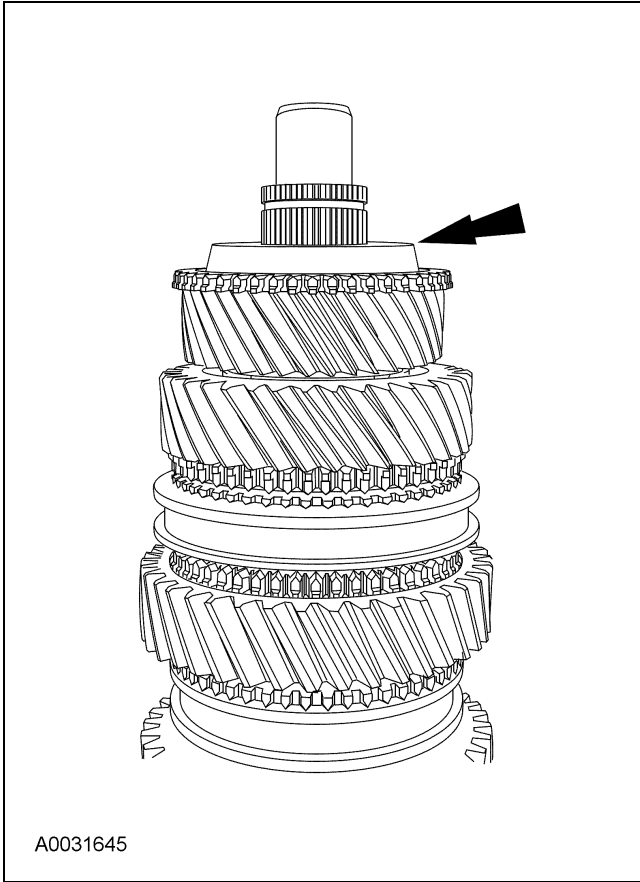

DISASSEMBLY AND ASSEMBLY (Continued)

30. **NOTE:** Install the synchronizer body with the raised center facing downward.

NOTE: Rotate the blocking ring until seated.

Install the 3rd/4th gear synchronizer body.

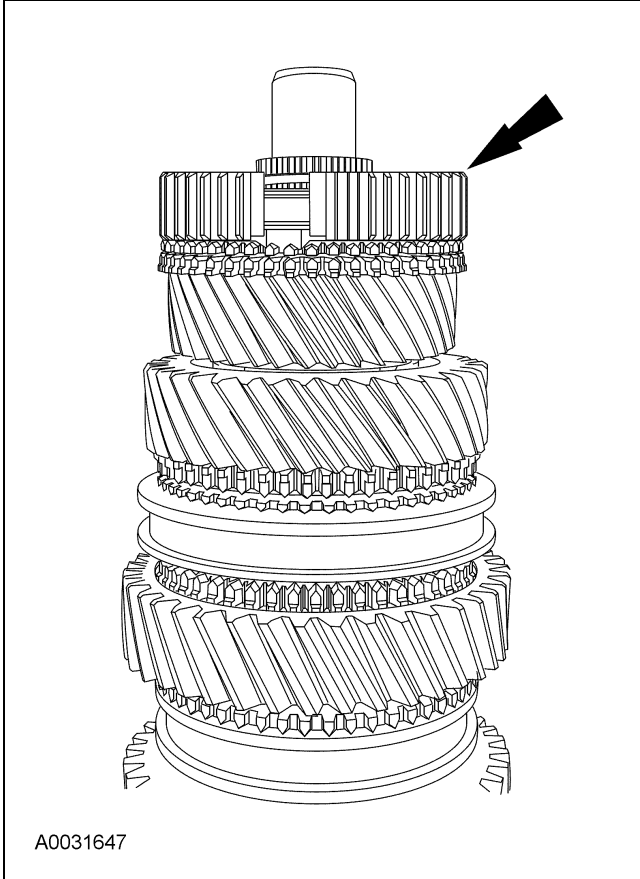

31. Install a new retaining ring.

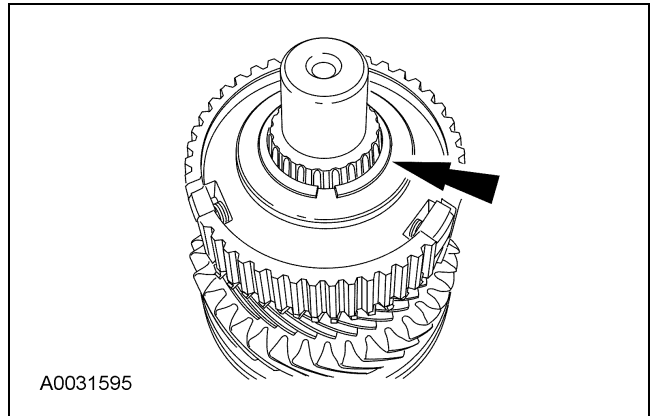

DISASSEMBLY AND ASSEMBLY

Countershaft Bearing

Special Tool(s)

	Remover, Drive Pinion Bearing Cone 205-D002 (D79L-4621-A) or equivalent
ST1895-A	

Transmission Internal Components — Countershaft Disassembled View

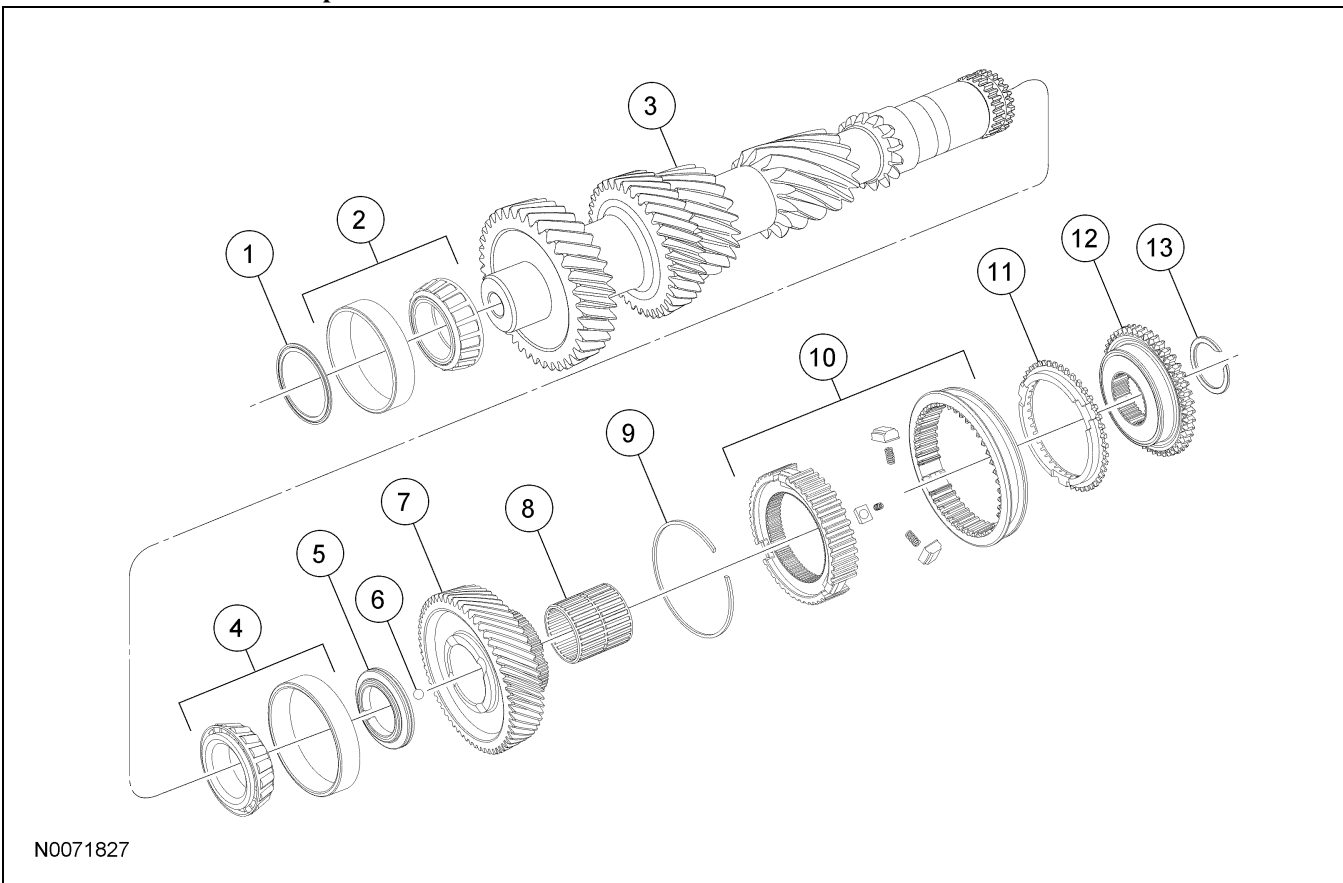

Item	Part Number	Description
1	7L172	Shim
2	7025	Countershaft front bearing and cup
3	7113	Countershaft
4	7025	Countershaft rear bearing and cup
5	7L271	Thrust bearing (part of spring kit)
6	7L271	Check ball (part of spring kit)

(Continued)

Item	Part Number	Description
7	7124	Countershaft 5th gear (part of 5th gear and synchronizer assembly)
8	7025	Countershaft 5th gear needle bearing
9	—	Retaining ring (part of 5th gear synchronizer assembly)
10	7124	Countershaft 5th gear and synchronizer assembly

(Continued)

DISASSEMBLY AND ASSEMBLY (Continued)

Item	Part Number	Description
11	7107	5th gear synchronizer blocking ring
12	7124	5th gear clutch cone
13	7L271	Retaining ring (part of spring kit)

Disassembly and Assembly

- Using a suitable tool, cut the outer cage, then remove the outer cage and rollers.

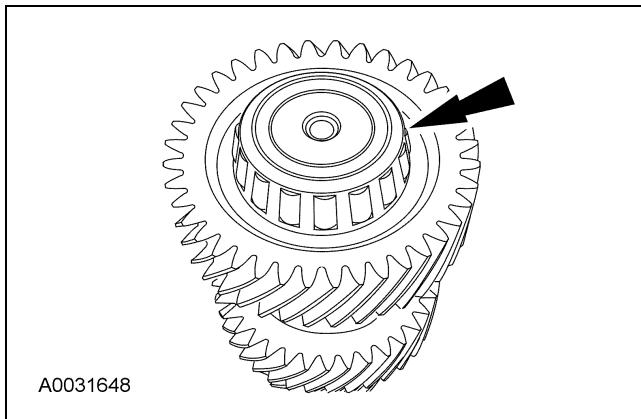

- Using the Drive Pinion Bearing Cone Remover and a press, remove the inner bearing.

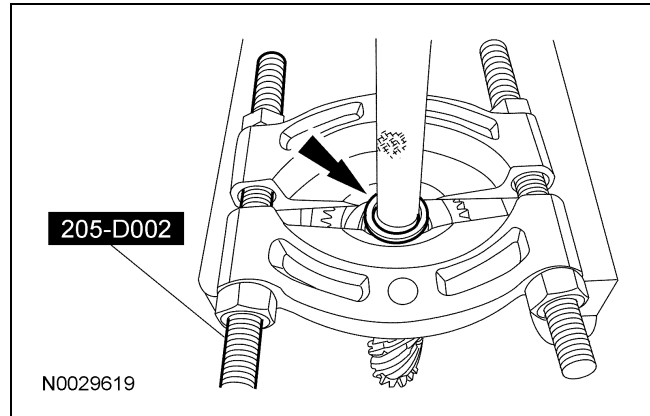

- Using a suitable tool, install the new countershaft bearing.

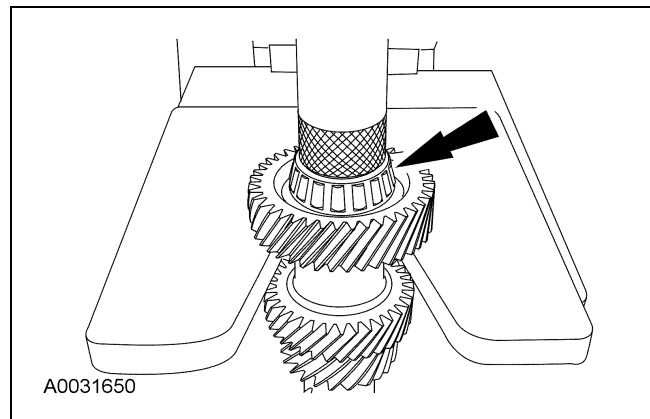

DISASSEMBLY AND ASSEMBLY

Synchronizers

Disassembly and Assembly

NOTE: This procedure applies to all synchronizer assemblies.

1. Scribe an alignment mark on the sliding sleeve and the hub for assembly reference.
2. Remove the sliding sleeve, then remove the synchronizer struts and the springs.

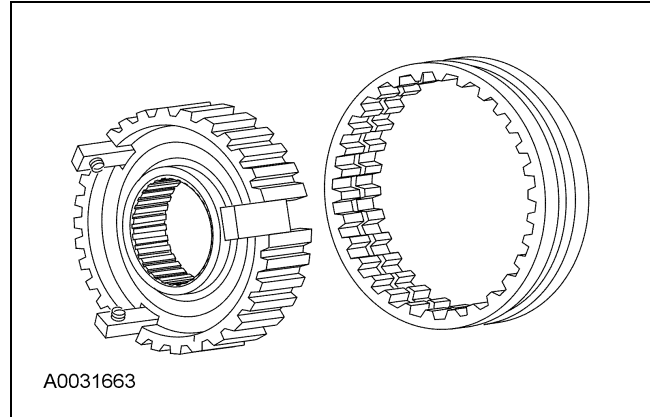

3. Install the synchronizer struts and the springs.
4. **NOTICE: Match the alignment marks made during disassembly. The sleeve and the hub have an extremely close fit. Hold the sleeve and hub square to prevent jamming. Do not force the sleeve onto the hub.**

Install the sliding sleeve.

DISASSEMBLY AND ASSEMBLY

Gearshift Rail Bushing

Special Tool(s)

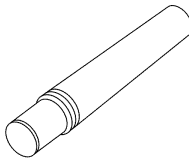
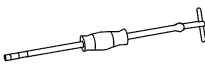
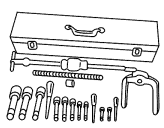
 <p>ST1085-B</p>	<p>Installer, Shift Rail Bushing 308-244 (T96P-7025-F)</p>
 <p>ST1185-A</p>	<p>Slide Hammer 100-001 (T50T-100-A)</p>
 <p>ST1144-A</p>	<p>Universal Puller Set 303-DS005 (D80L-100-A) or equivalent</p>

Disassembly and Assembly

1. Using the Slide Hammer and Universal Puller Set, remove the gearshift rail bearing from the transmission case. Discard the bearing.

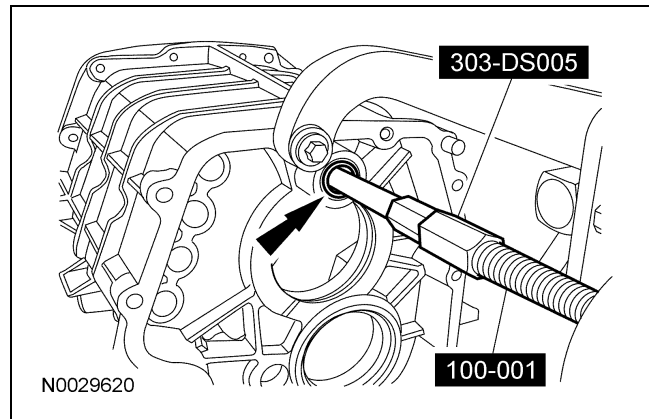

2. Using the Shift Rail Bushing Installer, install the main shift rail bearing.

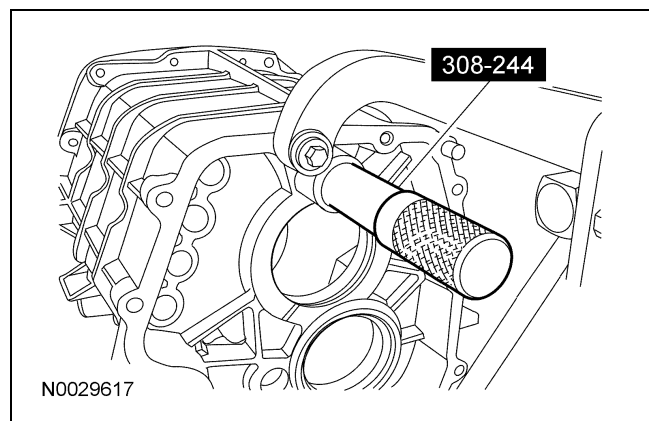

DISASSEMBLY AND ASSEMBLY

Gearshift Rail and Fork

Disassembly and Assembly

1. Using a 5/32-inch drift and a hammer, remove and discard the split pin. Slide the shift fork from the shift rail.

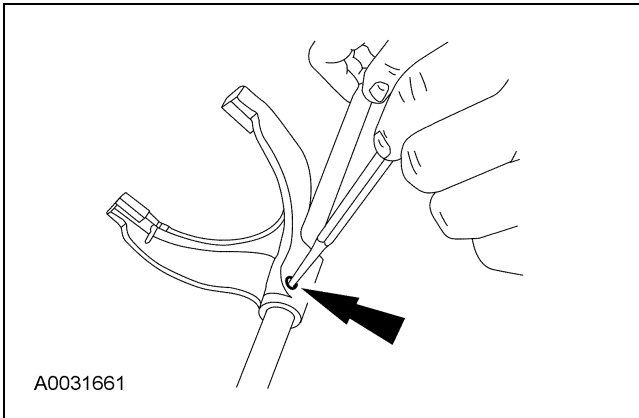

2. Remove the gearshift fork inserts.

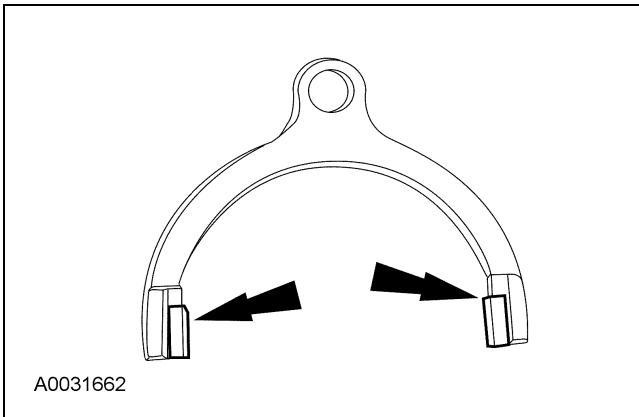

3. **NOTICE:** Support the shift rail to prevent damage to the parts.

Position the gearshift fork on the shift rail. Align the split pin hole and install a new split pin.

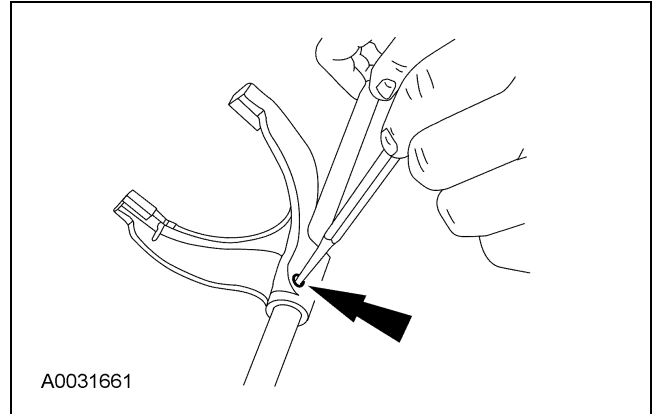

4. Install the gearshift fork inserts.

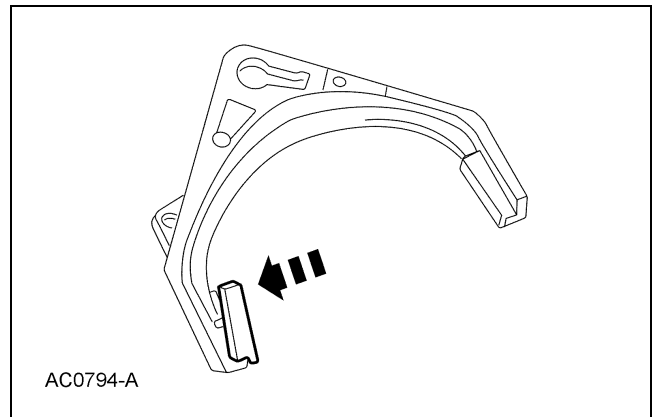

DISASSEMBLY AND ASSEMBLY

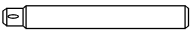
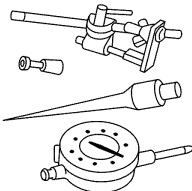
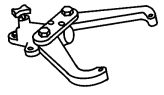
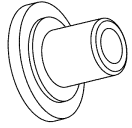
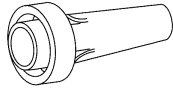

Transmission

Special Tool(s)

 ST1255-A	Adapter for 308-220 (handle) 205-153 (T80T-4000-W)
 ST1214-A	Dial Indicator Gauge with Holding Fixture 100-002 (TOOL-4201-C) or equivalent
 ST1186-A	Holding Fixture, Transmission 307-003 (T57L-500-B)
 ST2355-A	Installer, Input Shaft Oil Seal 308-220 (T94P-7025-AH)
 ST1087-A	Installer, Output Shaft Oil Seal 308-246 (T96P-7127-A) or use Installer, Drive Pinion Oil Seal 205-115

(Continued)

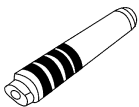
Special Tool(s)

 ST1303-A	Remover/Installer, Bearing Tube 308-024 (T75L-7025-B)
 ST2338-A	Replacer/Adapter 308-239 (T96P-7025-A)

Material

Item	Specification
Clear Silicone Rubber TA-32	ESB-M4G92-A
MERCON® V Automatic Transmission Fluid XT-5-QM (or XT-5-QMC) (US); CXT-5-LM12 (Canada)	MERCON® V
Threadlock and Sealer TA-25	WSK-M2G351-A5

DISASSEMBLY AND ASSEMBLY (Continued)

Transmission Case and Shift Components — Disassembled View

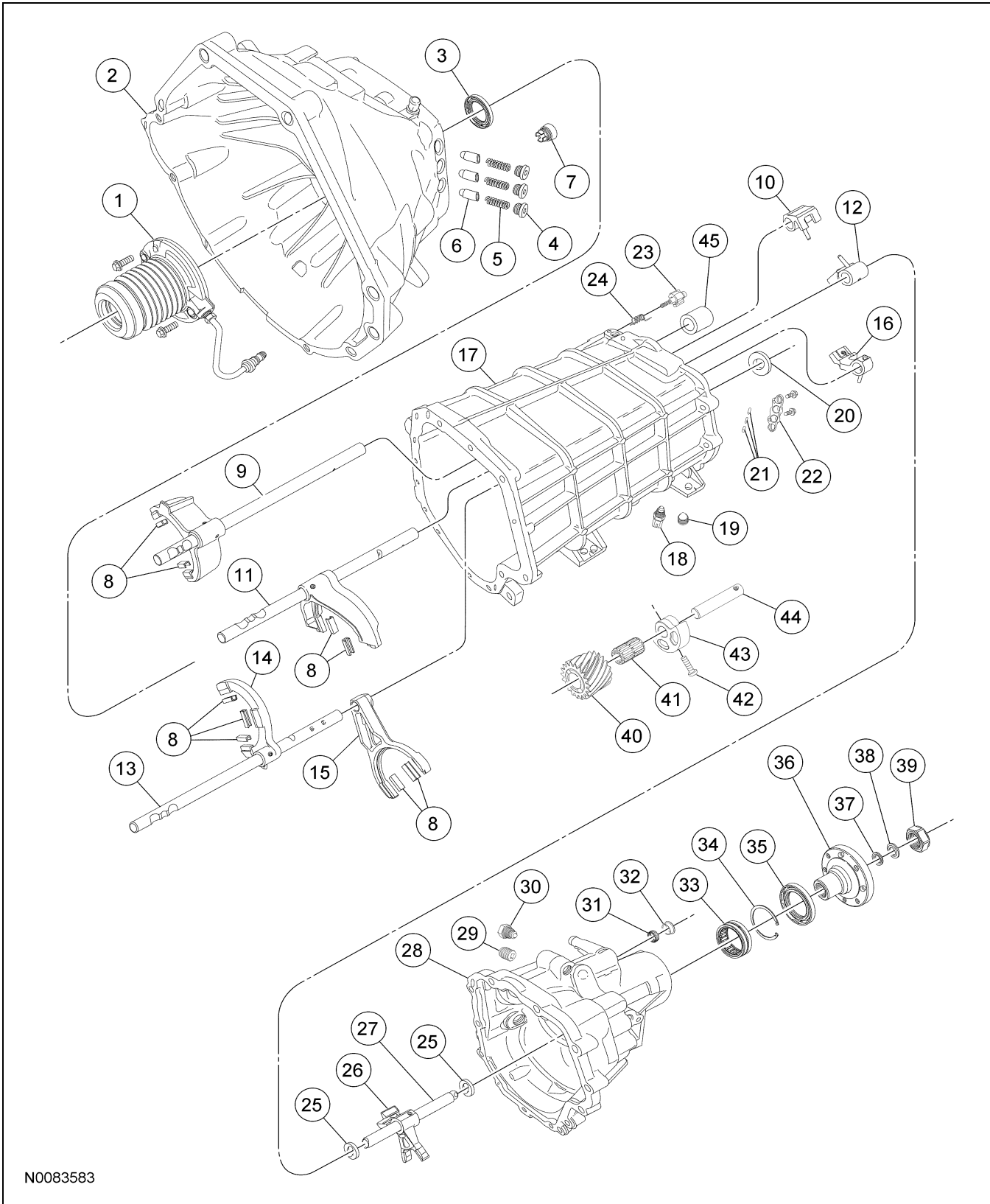

N0083583

DISASSEMBLY AND ASSEMBLY (Continued)

Item	Part Number	Description
1	7A508	Slave cylinder and release bearing
2	7500	Clutch housing
3	7052	Input shaft seal
4	7A082	Detent plug (part of detent kit)
5	7A082	Detent spring (part of detent kit)
6	7A082	Detent (part of detent kit)
7	7K584	Slave cylinder line retainer
8	7L082	Shift fork inserts
9	7K491	3rd/4th shift rail and fork
10	7K131	3rd/4th shift gate
11	7N346	1st/2nd shift rail and fork
12	7K130	1st/2nd shift gate
13	7242	5th/reverse shift rail and reverse shift fork
14	7230	Selector shift rail bearing
15	7230	5th gear shift fork
16	4L042	5th shift gate
17	7005	Transmission main case
18	15520	Reverse lamp switch
19	7A010	Drain plug
20	7L027	Magnet
21	7A082	Interlock pins (part of shift kit)
22	7229	Shift interlock plate
23	7A082	5th/reverse gear lockout (part of kit)
24	7A082	5th/reverse gear lockout spring (part of kit)
25	7A082	Spacers
26	7337	Selector finger
27	7240	Selector rail
28	7A039	Extension housing
29	7A010	Fill plug
30	7234	Detent/bias spring plunger
31	7127	Selector shift rail bearing
32	7052	Selector shift rail seal

(Continued)

Item	Part Number	Description
33	7025	Extension housing bearing/race assembly
34	7L271	Extension housing bearing snap ring (part of kit)
35	7052	Output shaft seal
36	7089	Transmission flange
37	7E397	Flange O-ring
38	7119	Flange washer
39	7K440	Flange nut
40	7141	Reverse idler gear
41	7025	Reverse idler gear needle bearing
42	7141	Reverse idler gear support bolt
43	7723	Reverse idler gear support
44	7140	Reverse idler gear shaft
45	—	Dowel (part of 7A039)

Assembly

NOTE: Install new roll pins, retaining rings or bearings that were removed during disassembly. Install bearings and bearing cups as a set.

1. Lubricate all components with transmission fluid during assembly.
2. Attach the clutch housing to the Transmission Holding Fixture.

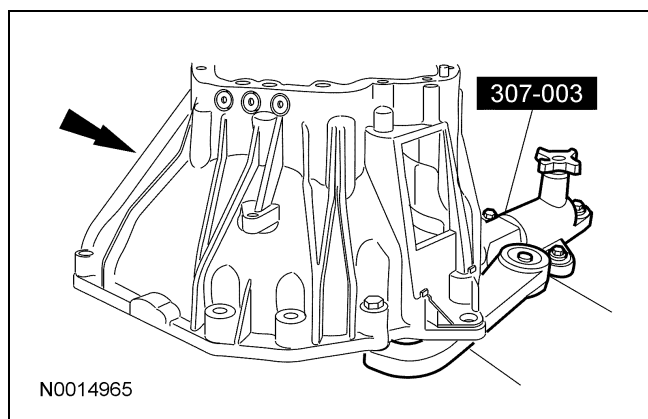

DISASSEMBLY AND ASSEMBLY (Continued)

3. **NOTE:** If a new rear output shaft bearing was installed or a new rear countershaft bearing is being used, install new bearing cups.

NOTE: Lubricate the bearing cups and the shift rail bearing with petroleum jelly.

Install the rear countershaft bearing cup and the rear output shaft bearing cup.

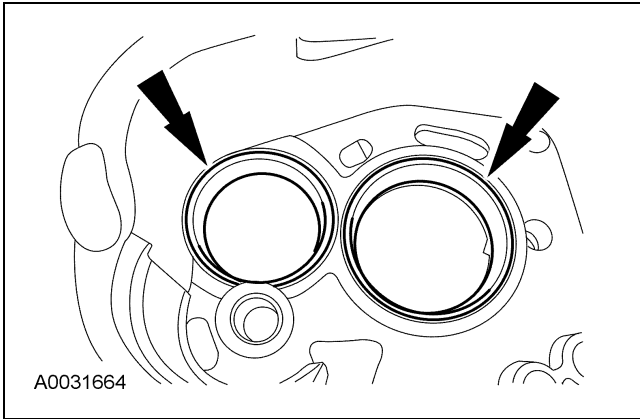

4. Install the rear countershaft bearing.

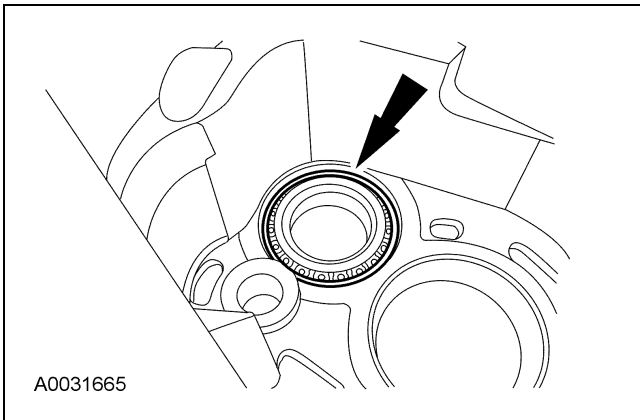

5. Install the reverse idler gear bearing on the reverse idler gear shaft.

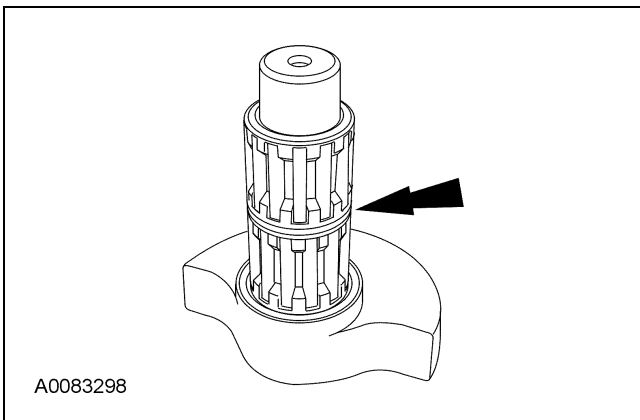

6. Install the reverse idler gear on the shaft.

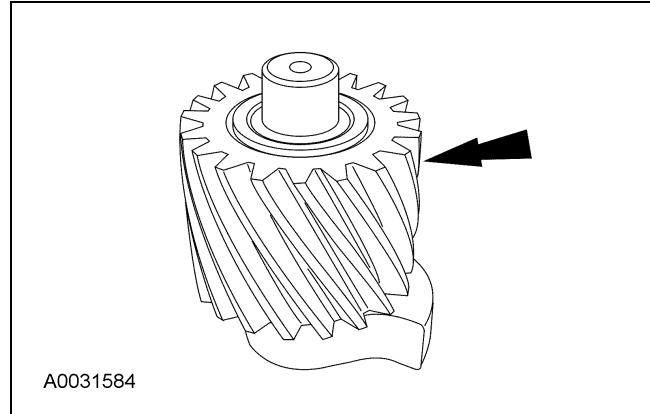

7. Install the reverse idler gear into the case.

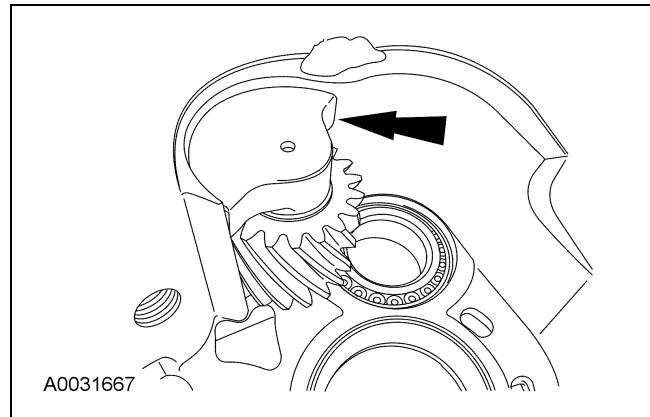

8. Install a new seal on the reverse idler bolt, then install the bolt in the transmission case.
- Tighten to 27 Nm (20 lb-ft).

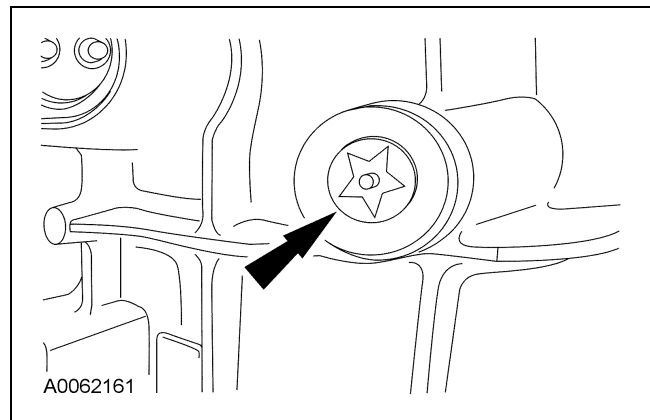

DISASSEMBLY AND ASSEMBLY (Continued)

9. **NOTE:** If a new front input shaft bearing or front countershaft bearing was installed, install new bearing cups.

Install the front input shaft bearing cup and the front countershaft bearing cup. Do not install the shims at this time.

- Install the transmission main case.

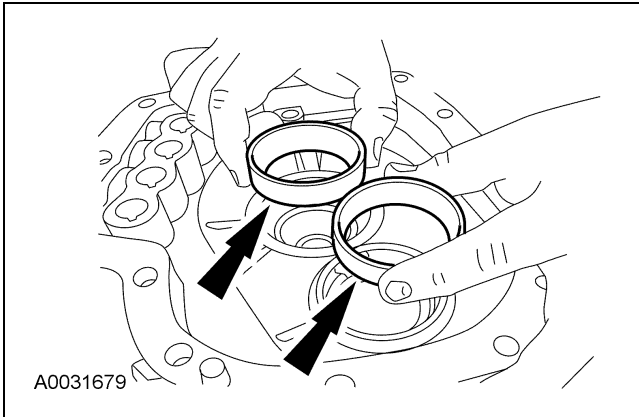

10. Install the input shaft with the 3rd/4th synchronizer blocking ring.

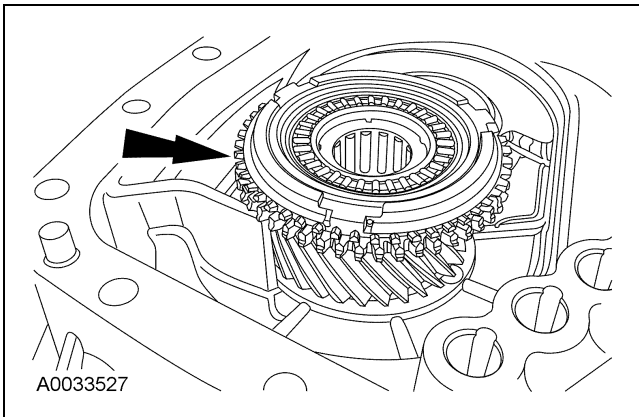

11. Install the shift rails and shift forks on the mainshaft.

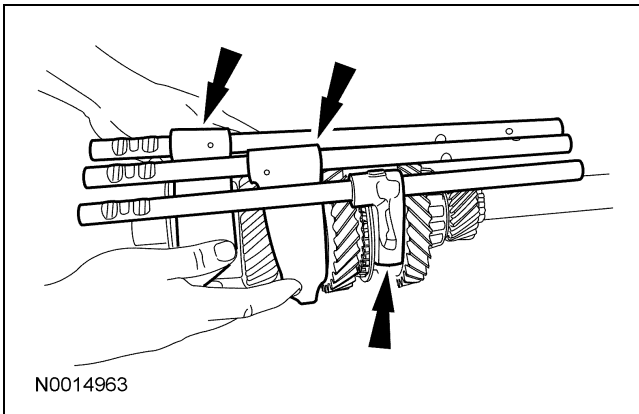

12. **NOTE:** The notches on the shift rail should be pointing upward.

NOTE: Align the shift rails in the bores.

NOTE: The 3rd/4th shift fork has an oil deflector that will line up with an oil deflector on the inside of the case.

NOTE: Make sure the 3rd/4th synchronizer blocking ring is aligned with the slots in the 3rd/4th synchronizer hub.

Install the mainshaft onto the clutch housing.

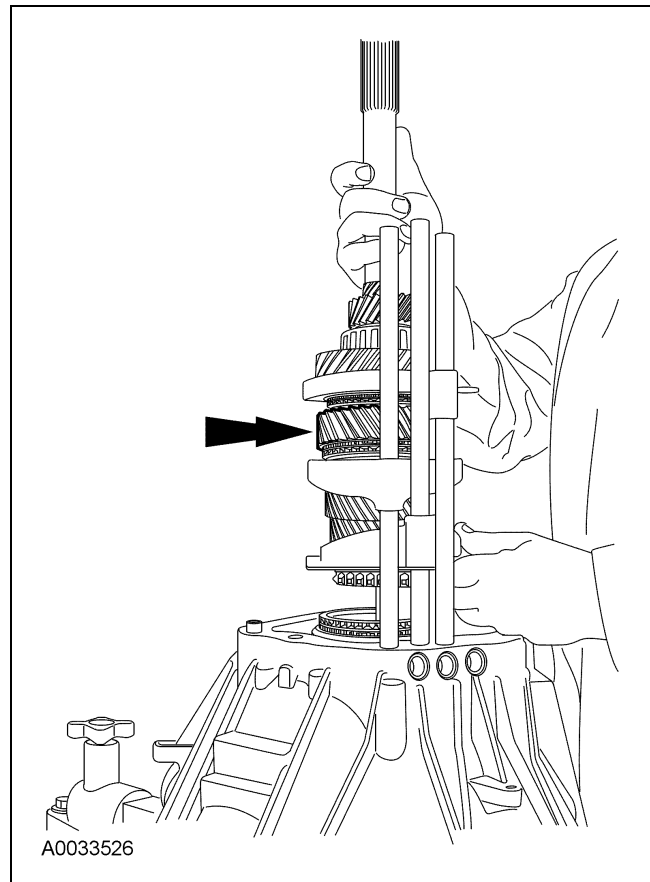

DISASSEMBLY AND ASSEMBLY (Continued)

13. **NOTE:** Make sure all synchronizer assemblies are in the neutral position.

Using a jack and a block of wood, lift the mainshaft 13 mm (0.50 in) upward, then tilt the countershaft inward and install the countershaft.

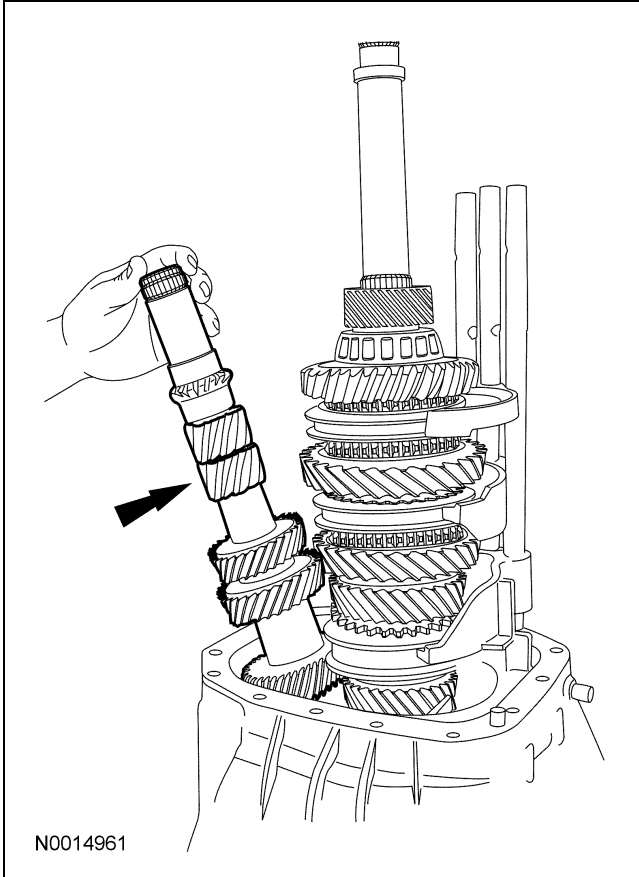

14. Install the case while holding the countershaft bearing in place. Install 2 opposing clutch housing-to-transmission main case bolts.

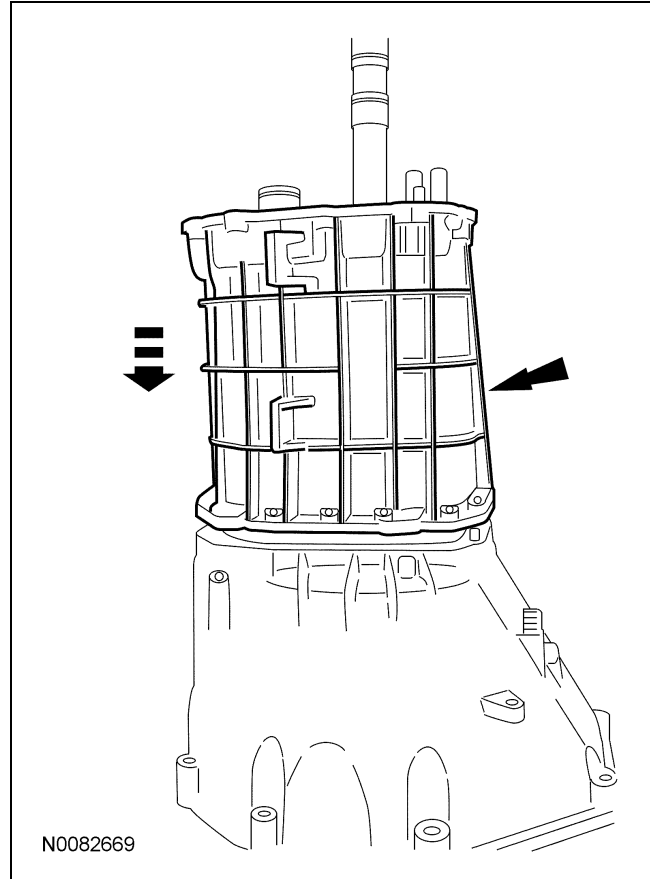

15. **NOTE:** Rotate the transmission so that the input shaft is pointing upward.

NOTE: Rotate the input shaft to seat the bearings.

Using the Dial Indicator Gauge with Holding Fixture, measure the input shaft end play by applying an upward load on the output shaft. Record the measurement.

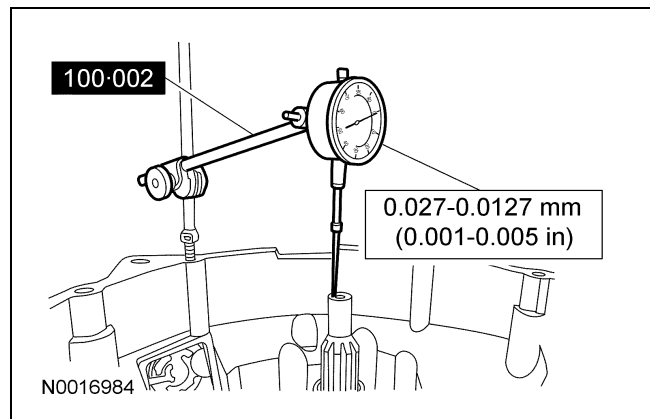

DISASSEMBLY AND ASSEMBLY (Continued)

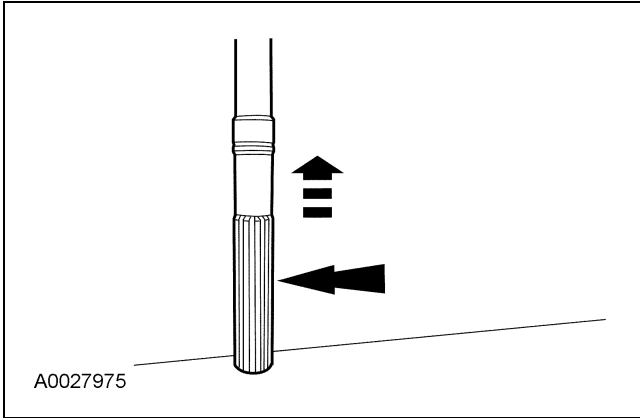

16. Rotate the transmission so that the input shaft is pointing downward.

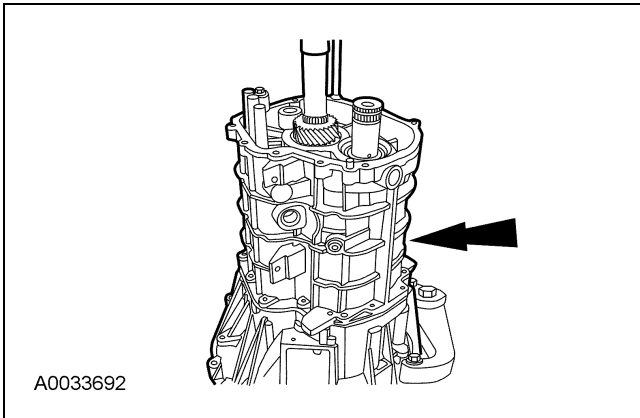

17. **NOTE:** Rotate the countershaft to seat the bearings.

Using the Dial Indicator Gauge with Holding Fixture, measure the countershaft gear end play by pulling upward on the countershaft. Record the measurement.

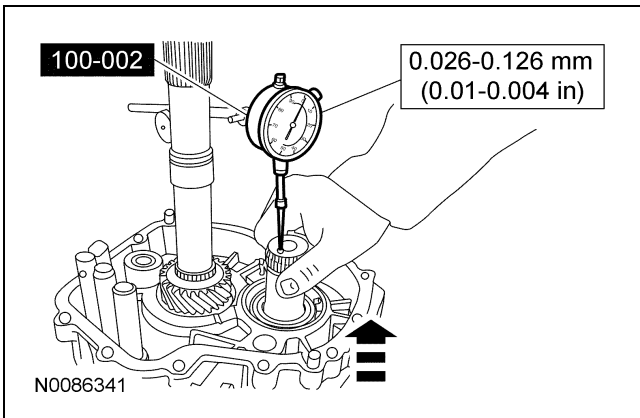

18. Remove the 2 bolts and lift the transmission main case off.

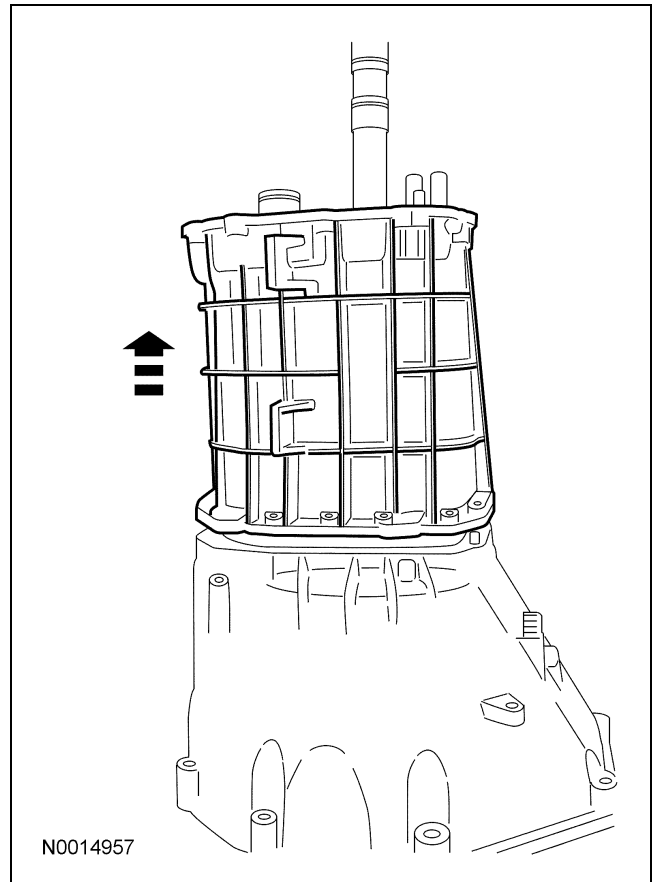

DISASSEMBLY AND ASSEMBLY (Continued)

19. Using a jack and a block of wood, lift the mainshaft 13 mm (0.50 in) upward, then tilt the countershaft outward and remove the countershaft.

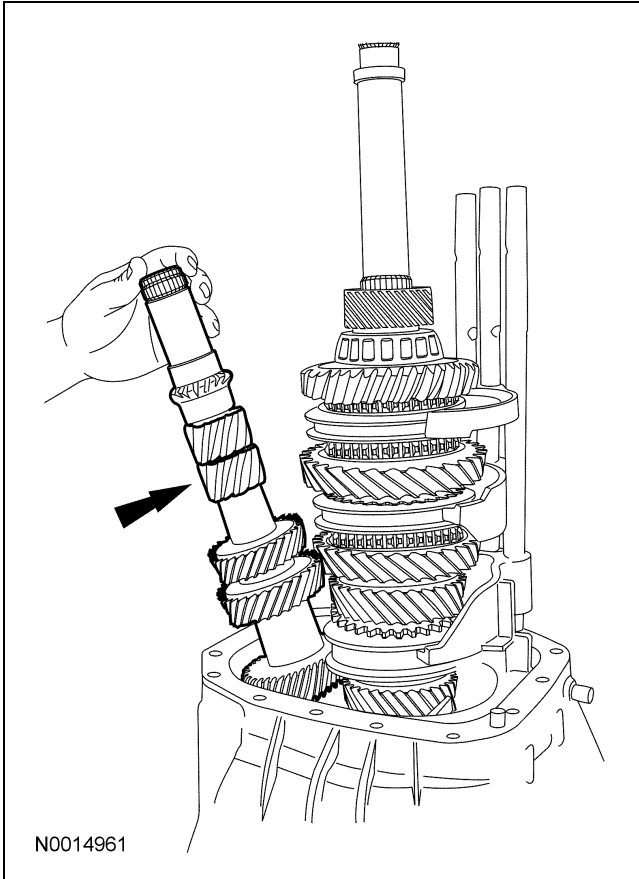

20. While holding the mainshaft, release the jack and remove the mainshaft and shift assembly.

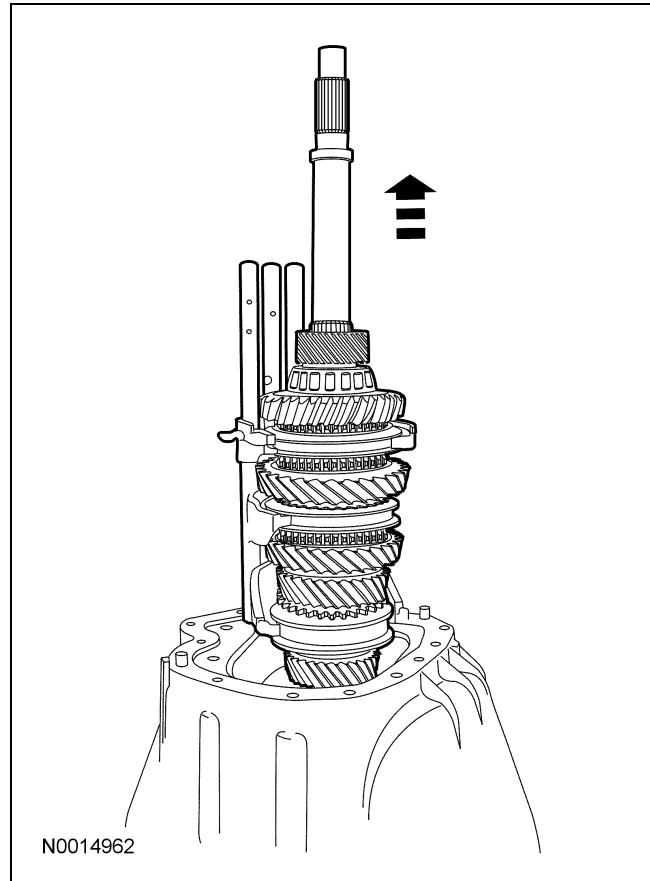

21. Remove the input shaft.

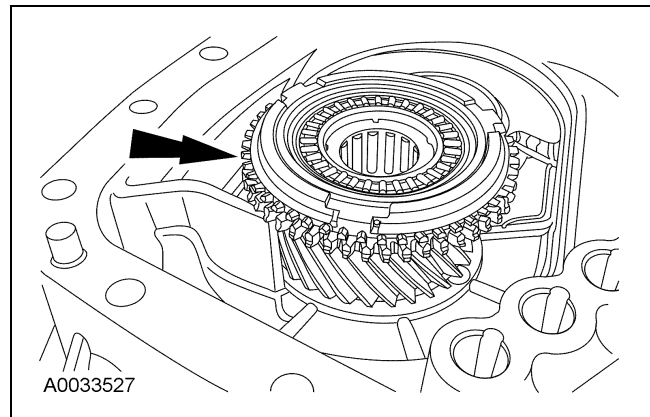

DISASSEMBLY AND ASSEMBLY (Continued)

22. Remove the front input shaft bearing cup and the front countershaft bearing cup.

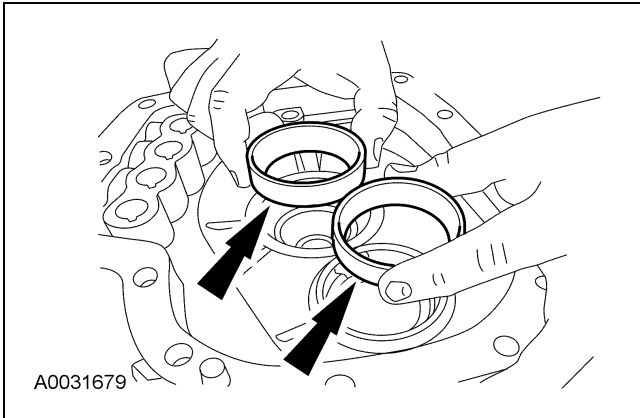

25. Install the front input shaft bearing cup and the front countershaft bearing cup.

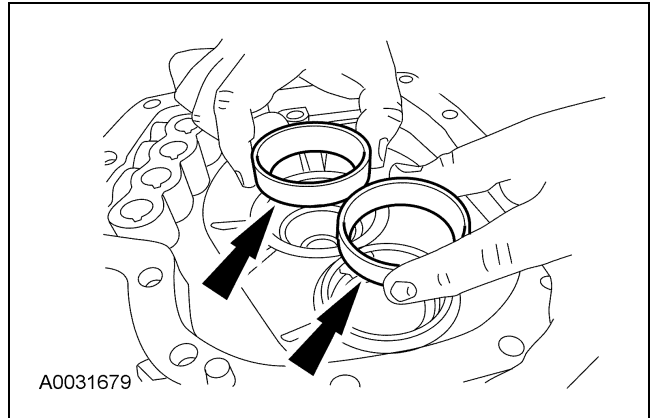

23. Using the Input Shaft Oil Seal Installer and Adapter, install the new input shaft seal.

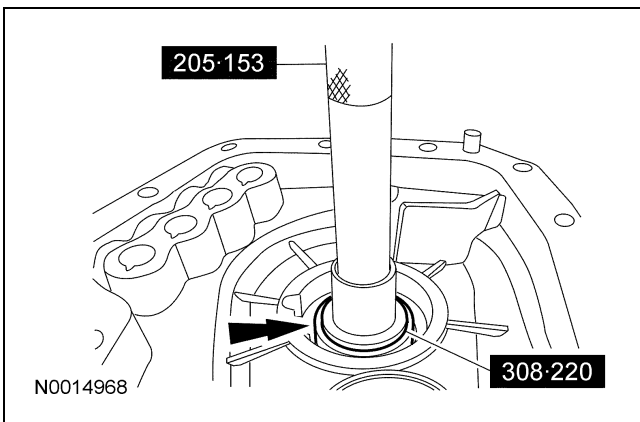

26. Install the input shaft and the 3rd/4th synchronizer blocking ring.

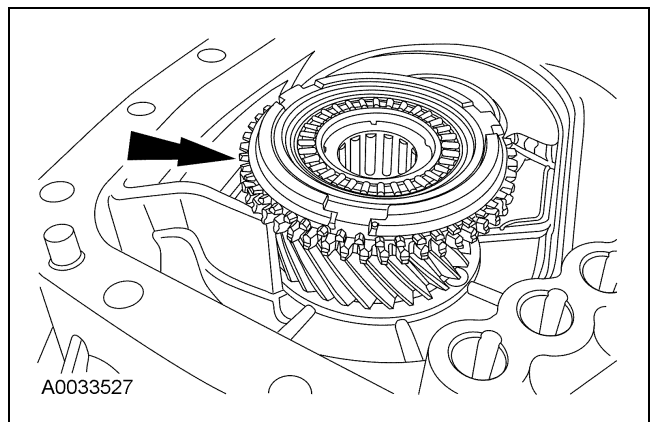

24. Using the recorded end play measurements, select and install the appropriate shims to achieve the correct end play.

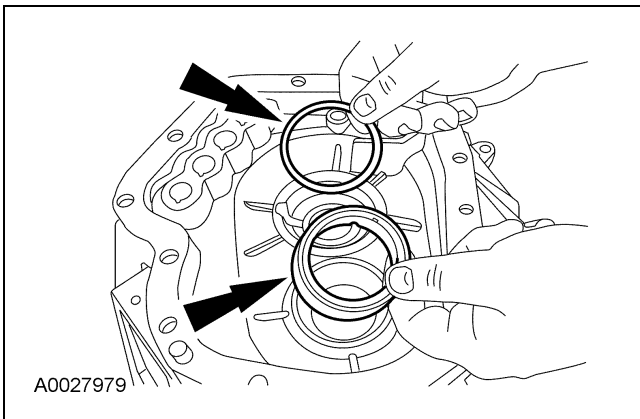

DISASSEMBLY AND ASSEMBLY (Continued)

27. **NOTE:** The notches on the shift rail should be pointing upward.

NOTE: Align the shift rails in the bores.

NOTE: The 3rd/4th shift fork has an oil deflector that will line up with an oil deflector on the inside of the case.

NOTE: Make sure the 3rd/4th synchronizer blocking ring is aligned with the slots in the 3rd/4th synchronizer hub.

Install the mainshaft.

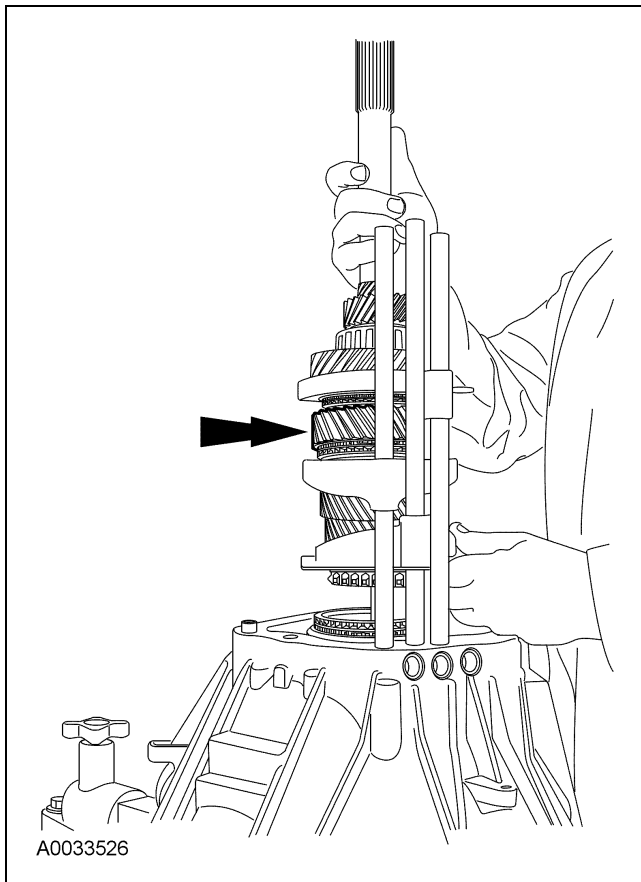

28. Using a jack and a block of wood, lift the mainshaft 13 mm (0.50 in) upward, then tilt the countershaft inward and install the countershaft.

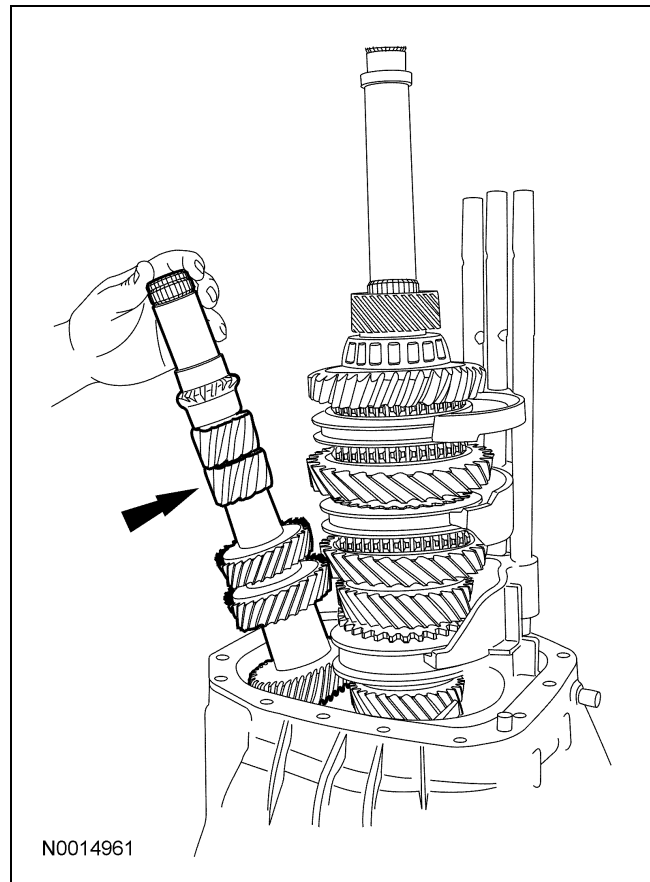

DISASSEMBLY AND ASSEMBLY (Continued)

29. Clean the mating surfaces of the transmission main case and the clutch housing. Apply a bead of silicone rubber to the sealing surface on the clutch housing, then install the transmission main case.

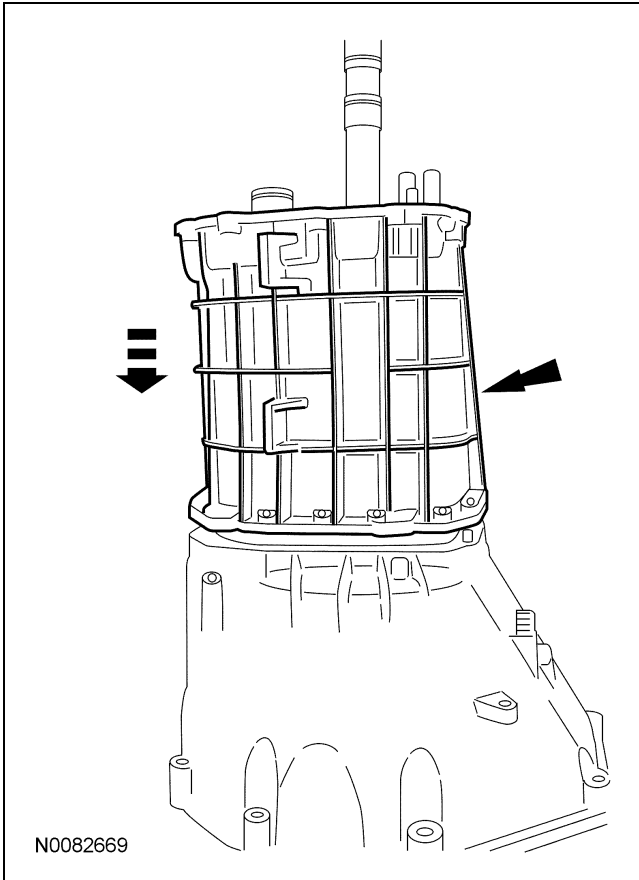

30. Install the clutch housing-to-main case bolts.

- Tighten the bolts in a star pattern to 32 Nm (24 lb-ft).

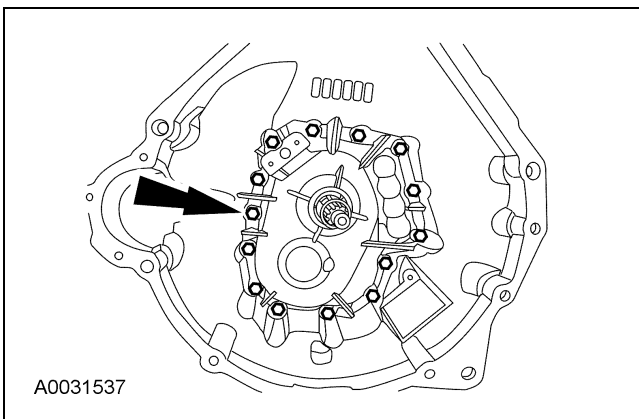

31. Install the lock pins.

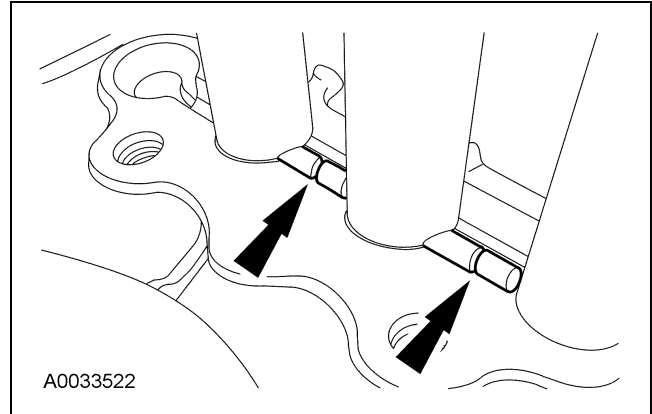

32. Install the lock plate and the lock plate bolts.

- Tighten to 31 Nm (23 lb-ft).

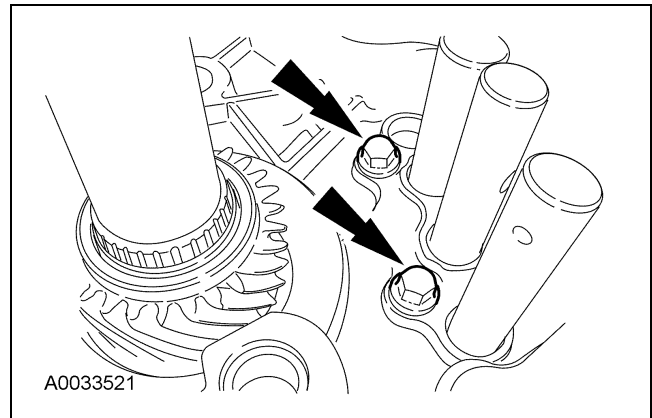

33. Install the 3 detents and the 3 detent springs.

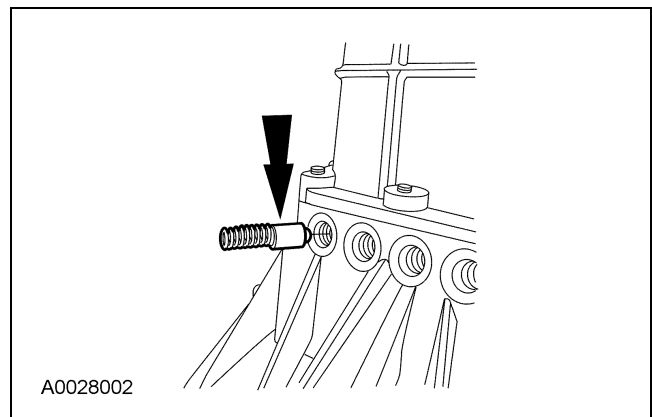

DISASSEMBLY AND ASSEMBLY (Continued)

34. Install the 3 detent plugs.

- Tighten to 28 Nm (21 lb-ft).

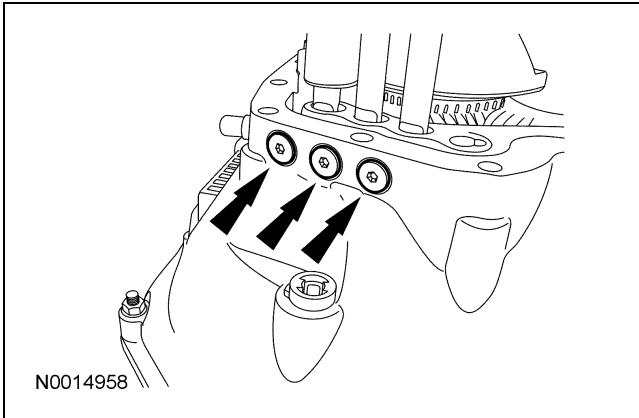

35. **NOTE:** Use petroleum jelly to hold the check ball in place.

Install the check ball.

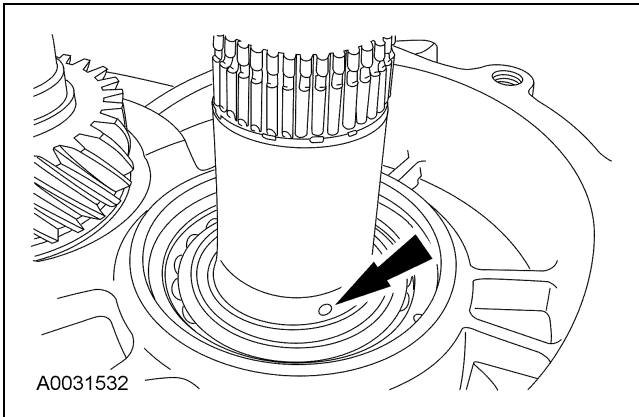

36. **NOTE:** The thrust washer is positioned with the flat surface facing upward towards 5th gear.

Install the thrust washer and the 5th gear needle bearings.

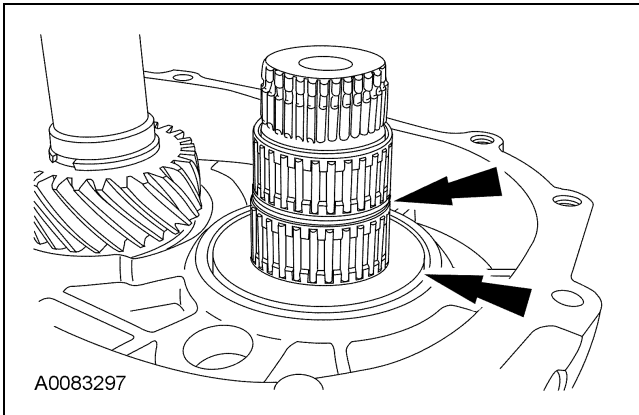

37. Place the 5th gear synchronizer blocking ring and the synchronizer hub on the countershaft 5th gear. Install the synchronizer springs and inserts.

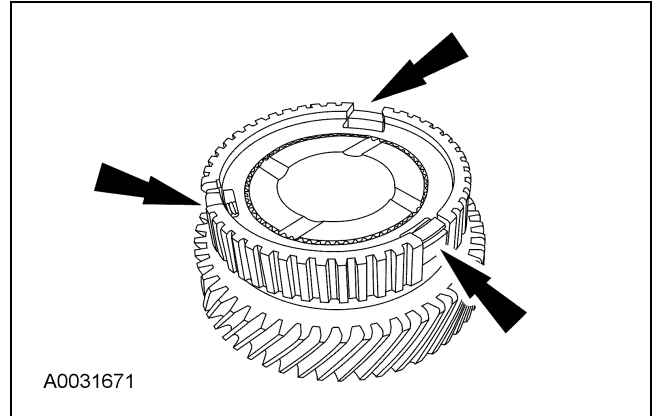

38. **NOTE:** Align the pockets in the blocking ring with the struts in the synchronizer.

NOTE: The sliding sleeve is not reversible. Install the sleeve with the pointed teeth on the synchronizer sleeve away from 5th gear.

Install the sliding sleeve on the synchronizer hub.

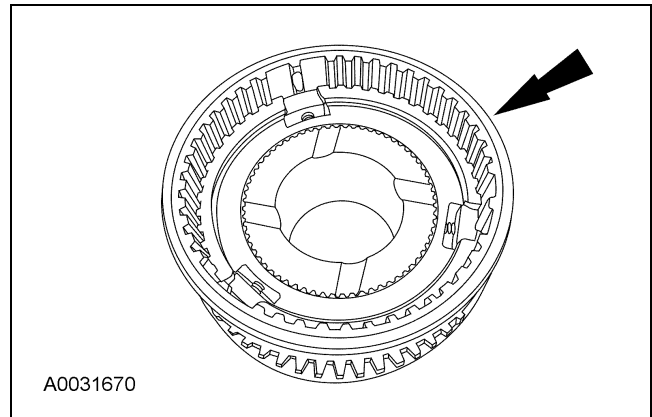

DISASSEMBLY AND ASSEMBLY (Continued)

39. Install 5th gear synchronizer blocking ring.

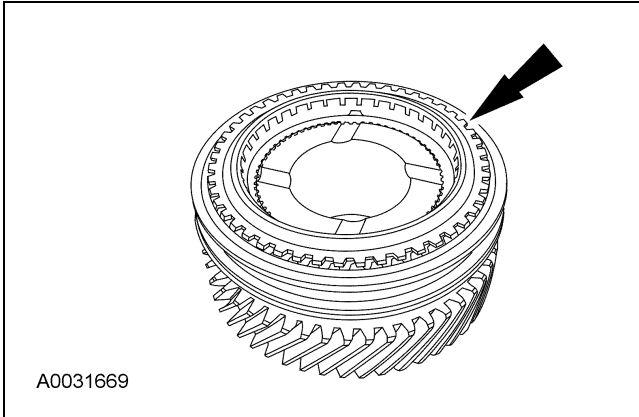

40. Install the 5th gear synchronizer cone.

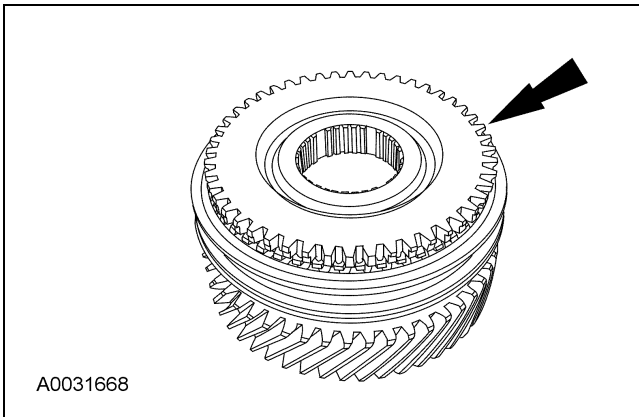

41. **NOTE:** Lubricate the shift rail with transmission fluid. Using a plastic hammer, alternately tap the shift fork and the synchronizer cone into position.

Install the shift arm and the 5th gear shift fork, the synchronizer assembly, the synchronizer cone and 5th gear as an assembly.

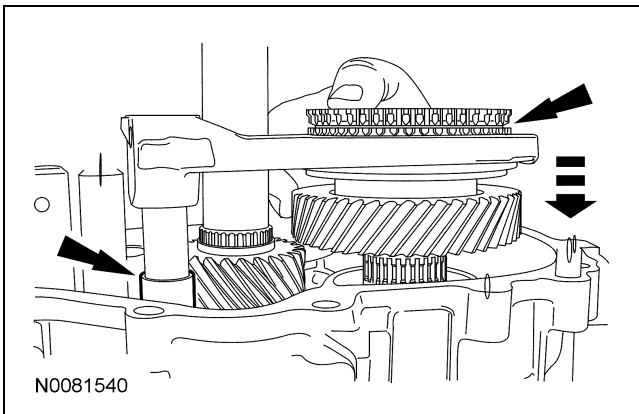

42. Install a new split pin.

- Install the pin until it is flush with the fork.

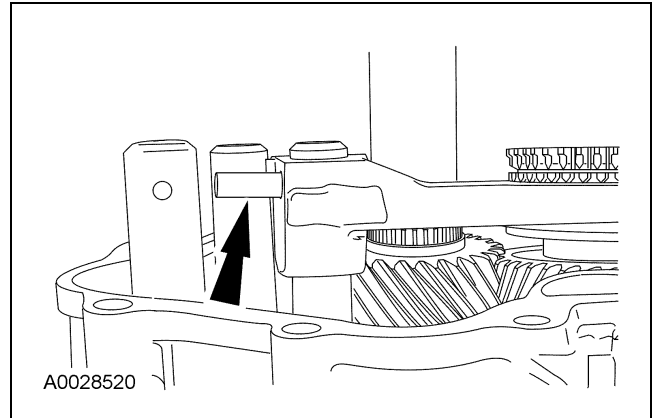

43. Install a new snap ring.

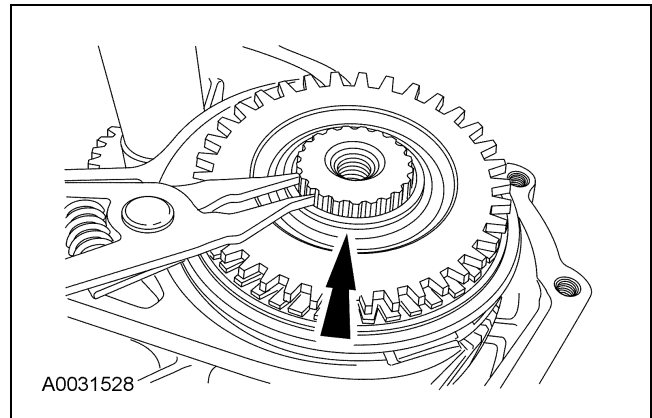

44. Install the 3rd/4th shift finger, then install a new split pin.

- Install the split pin until it is flush with the shift finger.

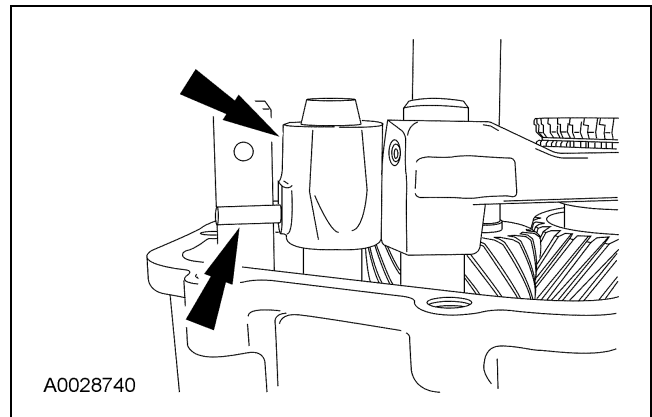

45. Install new plastic spacers on the main shift rail.

DISASSEMBLY AND ASSEMBLY (Continued)

46. Install the main shift rail, then install the 1st/2nd shift finger. Install new split pins.
- Install the split pins until it is flush with the shift finger and the shift rail.

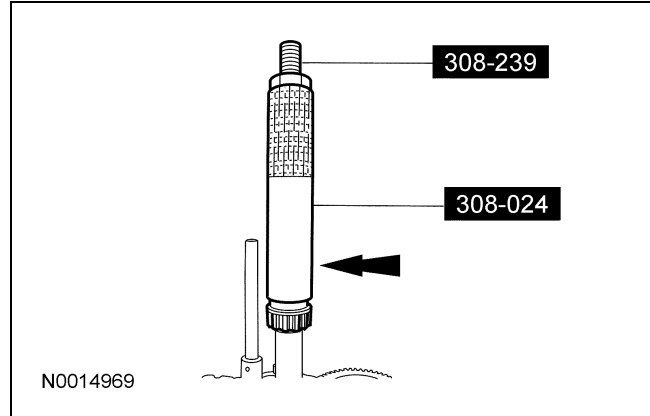
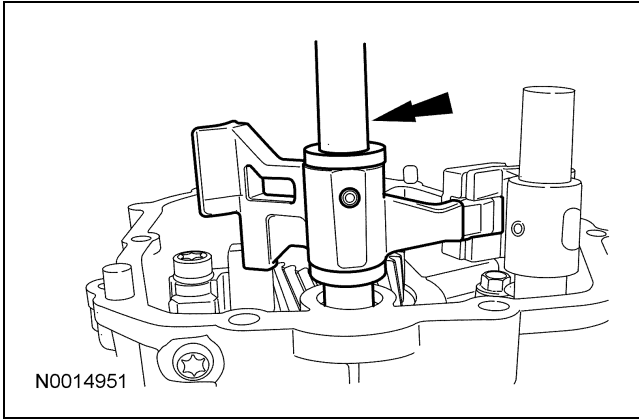

47. **NOTE:** Use petroleum jelly to hold the check ball in place.

Install the Output Shaft Speed (OSS) sensor tone wheel check ball.

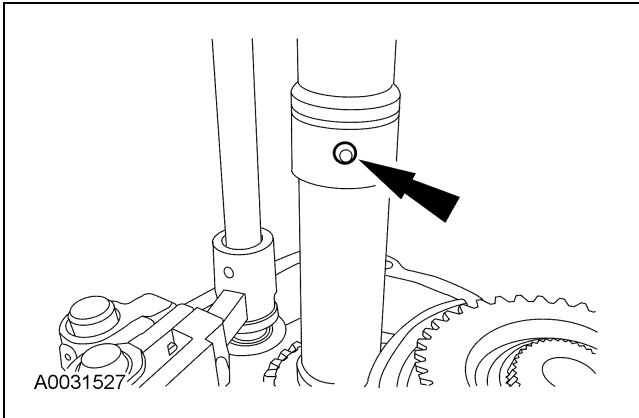

49. Install a new OSS sensor tone wheel retaining ring.

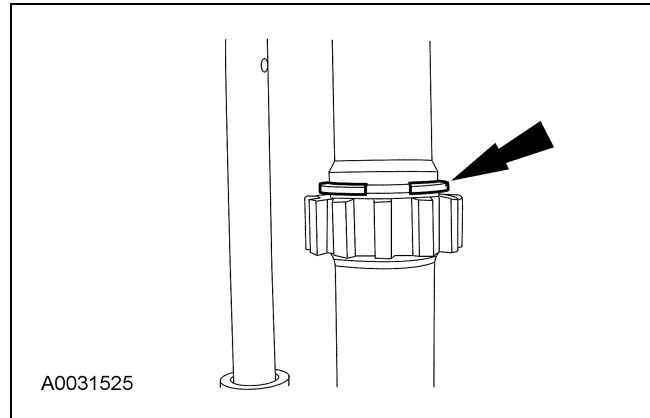

50. Install the 5th/reverse gear lockout spring, arm, seal and top bolt.

- Tighten to 20 Nm (177 lb-in).

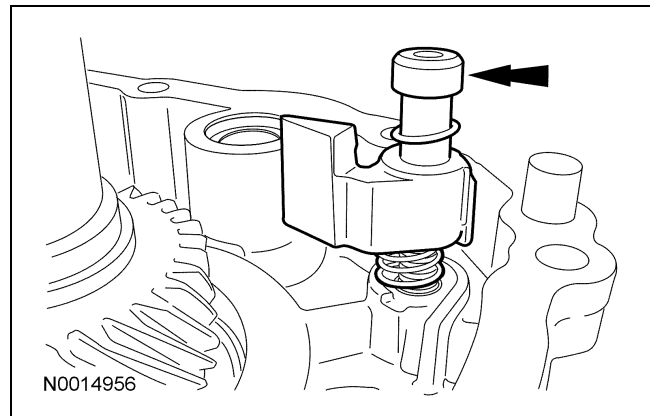

48. **NOTE:** The OSS sensor tone wheel is brittle. Gently tap the tone wheel into position. Place the OSS sensor tone wheel on the output shaft, aligning the slot in the OSS wheel with the check ball. Using the Bearing Tube Remover/Installer and Replacer/Adapter, install the OSS sensor tone wheel.

DISASSEMBLY AND ASSEMBLY (Continued)

51. Install the 5th/reverse gear lockout side bolt.
- Tighten to 20 Nm (177 lb-in).

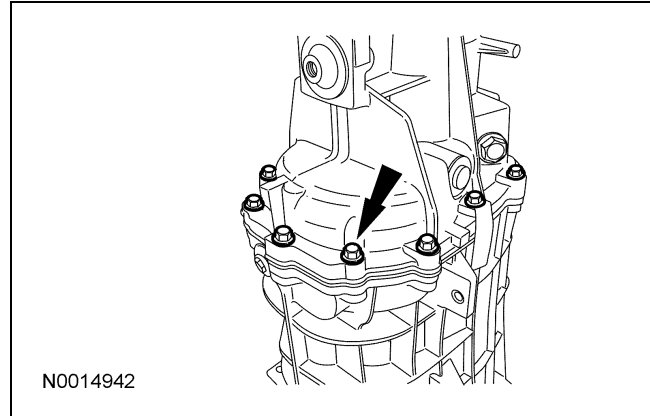
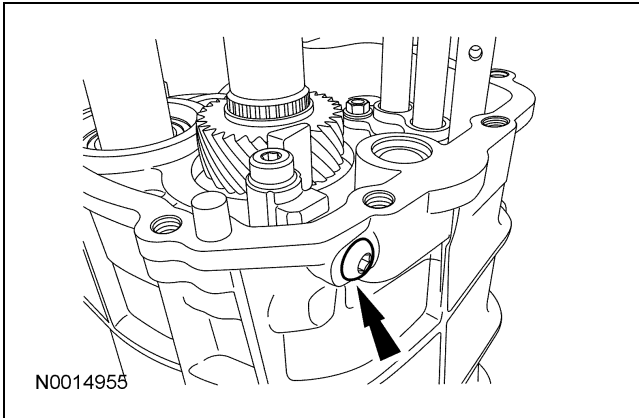

52. Clean the mating surfaces of the transmission main case and the extension housing. Apply a bead of silicone rubber to the sealing surface of the transmission case.

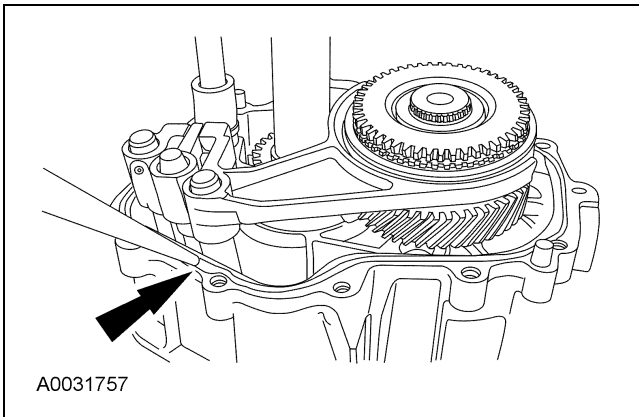

55. **NOTE:** If a new rear output shaft bearing was installed, install a new bearing cup.
Install the output shaft bearing.

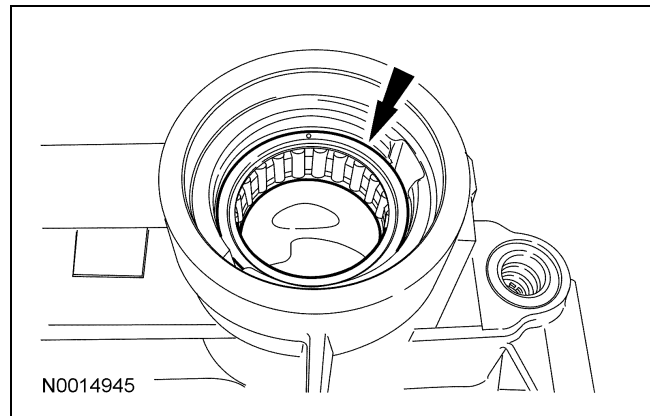

53. Install a new split pin in the gear shift offset lever.
- The split pin should be flush in the gear shift offset lever.

54. **NOTE:** Fill the gear shift offset lever with petroleum jelly.
Seat the extension housing and install the bolts.
- Tighten to 32 Nm (24 lb-ft).

56. Install the new snap ring.

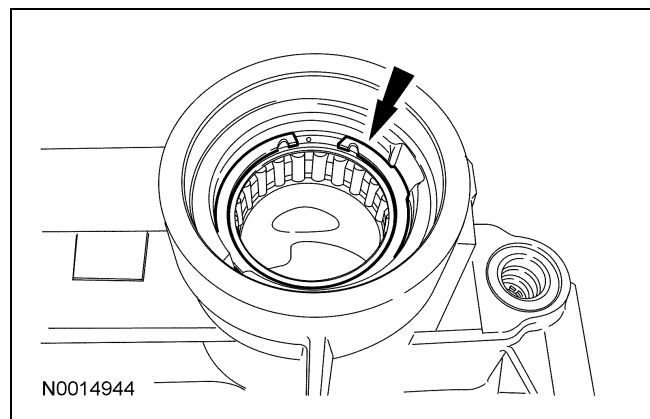

DISASSEMBLY AND ASSEMBLY (Continued)

57. **NOTE:** Lubricate the seal with transmission fluid.

Use the Output Shaft Oil Seal Installer to position the oil seal on the extension housing and the Drive Pinion Oil Seal Installer to seat the seal.

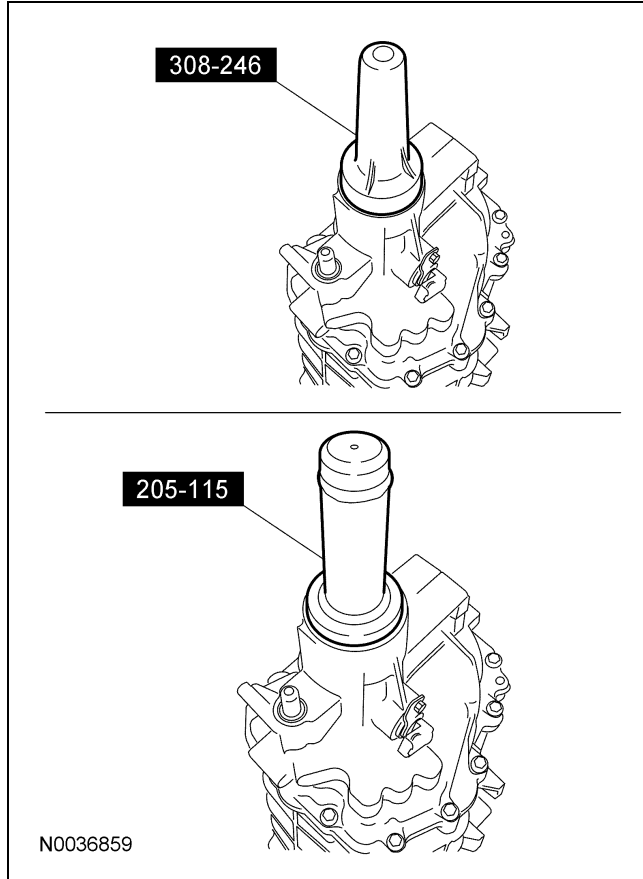

58. Install the OSS sensor.

- Tighten to 10 Nm (89 lb-in).

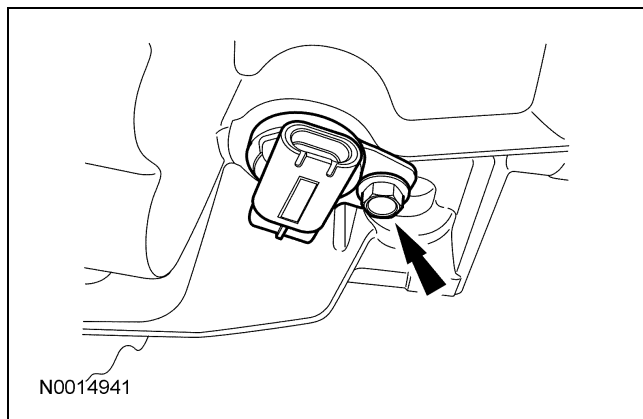

59. Install the reversing lamp switch.

- Tighten to 27 Nm (20 lb-ft).

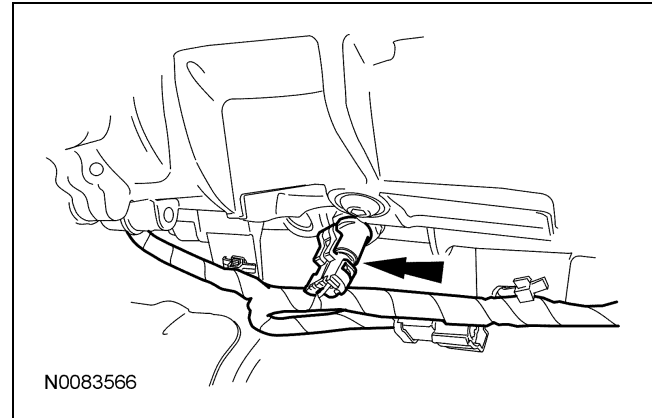

60. Position the output flange onto the output shaft. Install the thrust washer and the output flange nut and tighten until the output flange is fully seated onto the output shaft.

61. Remove the output flange nut and thrust washer.

62. Install a new output flange seal. Carefully push it through until it is fully seated against the output flange pocket.

63. Install the output flange washer and the output flange nut.

- Tighten to 142 Nm (105 lb-ft).

64. Install a new plastic retainer.

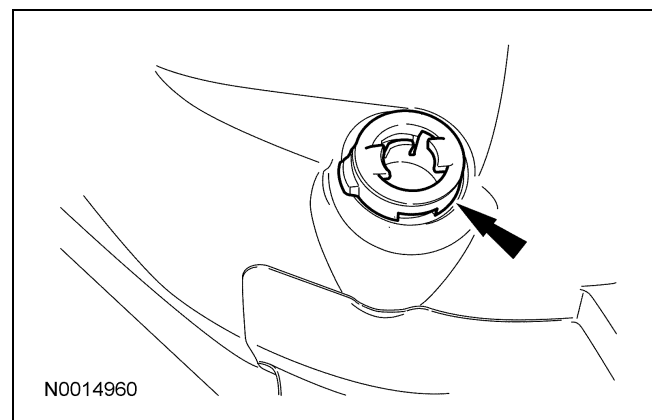

DISASSEMBLY AND ASSEMBLY (Continued)

65. Install the clutch slave cylinder. For additional information, refer to Section 308-02.

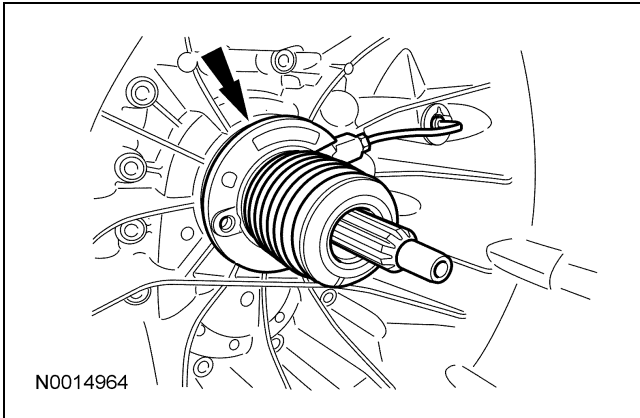

66. Install the clutch slave cylinder connector and engage the clip.

67. Fill the transmission with transmission fluid to the specified level.

- Transmission capacity is 3.0L (6.3 pt).

68. Apply threadlock and sealer to the fill plug threads and install the fill plug.

- Tighten to 25 Nm (18 lb-ft).

REMOVAL AND INSTALLATION

Transmission

Material

Item	Specification
MERCON® V Automatic Transmission Fluid XT-5-QM (or XT-5-QMC) (US); CXT-5-LM12 (Canada)	MERCON® V
Premium Long-Life Grease XG-1-C or XG-1-K (US); CXG-1-C (Canada)	ESA-M1C75-B
Threadlock and Sealer TA-25	WSK-M2G351-A5

Installation

- NOTE:** Before installing the transmission, the input shaft must be cleaned and lubricated with a small amount of grease.

Position the transmission to the transmission jack at a 30 degree counterclockwise angle and securely strap the transmission to the transmission jack.

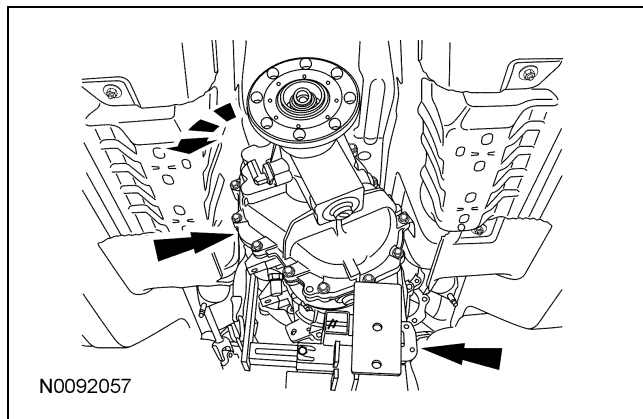

- Position the transmission to the engine. Rotate the transmission clockwise and align the dowels.
- NOTE:** Insert the clutch hydraulic tube into the clutch slave cylinder and install the clip before tightening the transmission-to-engine bolts.

Install the 7 transmission-to-engine bolts.

- Tighten to 45 Nm (33 lb-ft).

- Install the 2 spacer plate bolts.
 - Tighten to 35 Nm (26 lb-ft).
- Attach the wire harness retainer clip to the transmission.

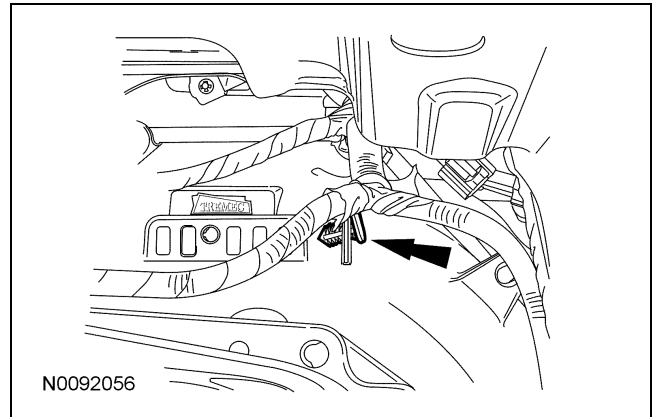

- Connect the shift linkage to the transmission and install the transmission shift arm bolt.
 - Tighten to 40 Nm (30 lb-ft).

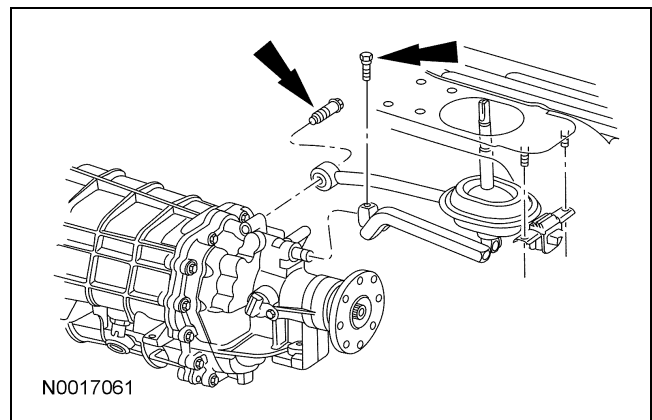

- NOTE:** The hump side of the crossmember goes up.

Install the transmission crossmember. For additional information, refer to Section 502-00.

REMOVAL AND INSTALLATION (Continued)

8. Connect the Output Shaft Speed (OSS) sensor electrical connector and attach the wiring harness to the transmission.

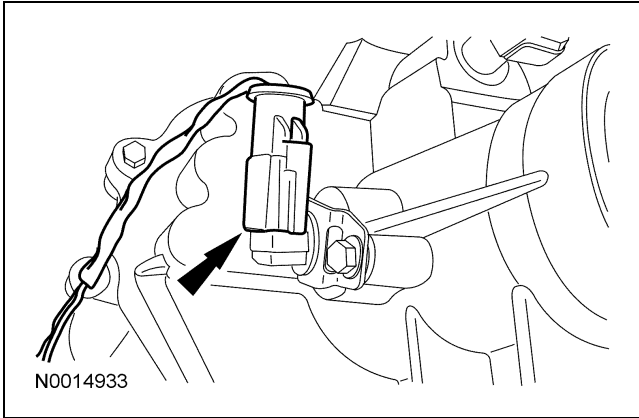

9. Install the catalytic converter H-pipe. For additional information, refer to Section 309-00.
10. Connect the reverse lamp switch electrical connector and attach the wiring harness to the transmission.

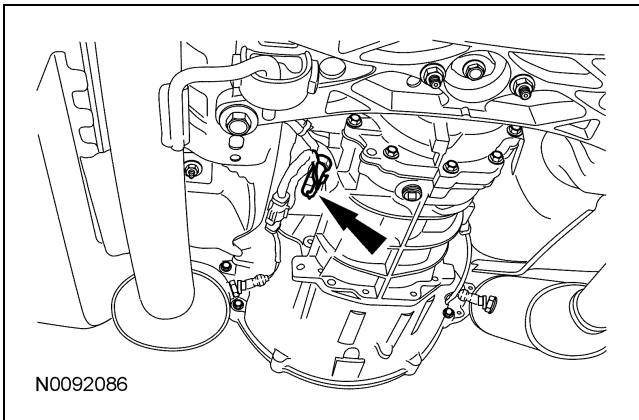

11. Install the subframe cross brace and the 4 subframe cross brace nuts.
- Tighten to 48 Nm (35 lb-ft).

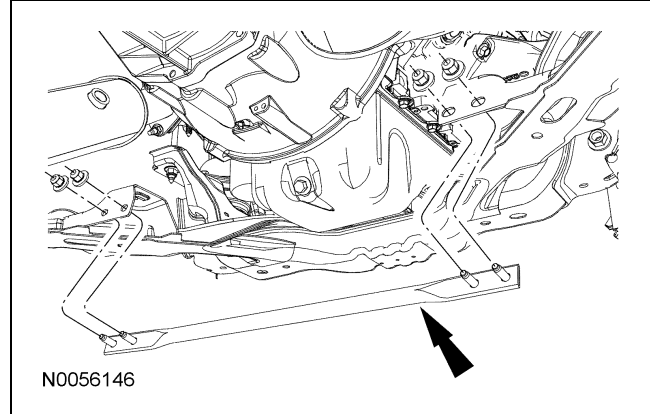

12. Install the starter and the 3 starter motor bolts.
- Tighten to 25 Nm (18 lb-ft).

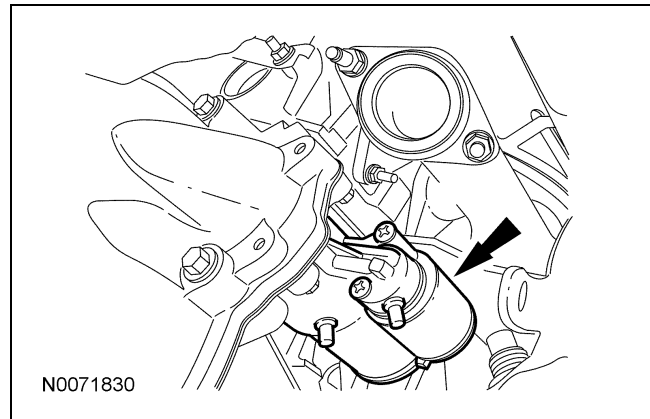

13. Install the driveshaft. For additional information, refer to Section 205-01.
14. Fill the transmission with transmission fluid as necessary. For additional information, refer to Transmission Draining and Filling in this section.
15. Connect the battery ground cable. For additional information, refer to Section 414-01.
16. Fill the brake and clutch reservoir. Bleed the clutch hydraulic system. For additional information, refer to Section 308-00.

SPECIFICATIONS

Material

Item	Specification	Fill Capacity
MERCON® V Automatic Transmission Fluid XT-5-QM (or XT-5-QMC) (US); CXT-5-LM12 (Canada)	MERCON® V	3.46L (3.65 qt)
Premium Long-Life Grease XG-1-C or XG-1-K (US); CXG-1-C (Canada)	ESA-M1C75-B	—
Silicone Gasket and Sealant TA-30	WSE-M4G323-A4	—
Threadlock and Sealer TA-25	WSK-M2G351-A5	—

General Specifications

Item	Specification
Preload	
Countershaft cluster gear preload	0.0127 mm (0.0005 in) - 0.0889 mm (0.0035 in)
Input/output shaft preload	0.0127 mm (0.0005 in) - 0.0889 mm (0.0035 in)

Torque Specifications

Description	Nm	lb-ft	lb-in
Clutch slave cylinder bolts	12	—	106
Drain plug	27	20	—
Extension housing bolts	48	35	—
Filler plug	27	20	—

Torque Specifications (Continued)

Description	Nm	lb-ft	lb-in
Gearshaft lever bolt	40	30	—
Gearshift lever upper bolts	35	26	—
Guide plate bolts	22	16	—
Lower gearshift lever bolts	20	—	177
Output shaft flange nut ^a	—	—	—
Output Shaft Speed (OSS) sensor bolt	10	—	89
Rear gearshift lever nuts	20	—	177
Reverse idler shaft bracket bolts	30	22	—
Reverse lockout solenoid bolt	18	—	159
Reversing lamp switch	27	20	—
Shift detent	40	30	—
Shift detent cover bolts	20	—	177
Shift lever guide bolts	27	20	—
Subframe cross brace bolts	48	35	—
Transmission insulator center bolt	70	52	—
Transmission main case-to-clutch housing bolts	48	35	—
Transmission mount outer bolts	63	46	—
Transmission-to-engine bolts	45	33	—
Upper gearshift lever bolts	35	26	—

a Refer to the procedure in this section.

DESCRIPTION AND OPERATION

Manual Transmission

The TR-6060 6-speed manual transmission features:

- six forward speeds and one reverse speed.
- forward gears are synchronized and helical cut.
- a reverse gear operates through a constant-mesh, fully synchronized system.
- a shift interlock system prevents the engagement of more than one gear.
- the countershaft is a one-piece design for added torque capacity.
- two tapered roller bearings on the output shaft.
- two tapered roller bearings on the countershaft cluster.
- a tapered roller bearing on the input shaft.
- a tapered roller bearing on the countershaft extension.
- countershaft cluster endplay controlled by shims located in the transmission clutch housing.
- input/output shaft endplay is controlled by shims located in the transmission clutch housing.
- removable wear pads on the shift forks.
- an aluminum main case, extension housing and clutch housing.

The transmission function is to move the vehicle from a rest position to motion. This is done by transferring the engine torque, through the transmission, to the vehicle rear wheels. The transmission input shaft receives power when the clutch is engaged. Torque flows through the input shaft to the drive gear. The torque travels downward to the countershaft drive gear and is delivered along the countershaft to all the countershaft gears. The torque is then transferred upward to the engaged mainshaft gear. The transmission uses a system of mainshaft gears to change the speed and torque relationship between the engine crankshaft and the transmission output shaft.

Transmission Identification

The transmission identification tag is located under the lower bolt that retains the extension housing to the main case.

The 6 speed (TR-6060) transmission is available for the Mustang Shelby GT500 5.4L (4V).

Transmission Identification

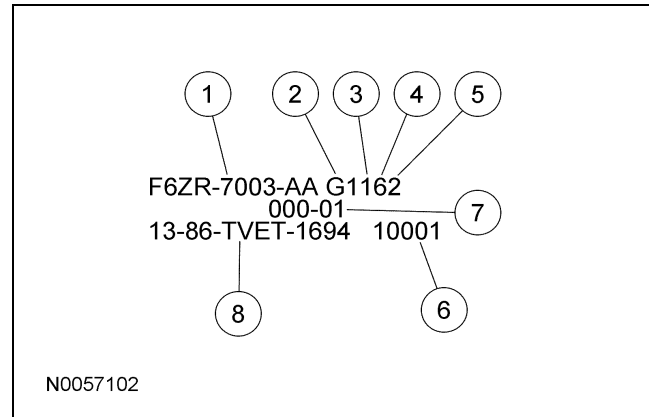

Item	Part Number	Description
1	7003	Transmission assembly number
2	—	Build date code — month
3	—	Build date code — day
4	—	Build date code — year
5	—	Shift number
6	—	Serial number
7	—	Service repair code

(Continued)

DESCRIPTION AND OPERATION (Continued)

Item	Part Number	Description
8	—	Identification number located on left lower side of transmission case

DIAGNOSIS AND TESTING

Manual Transmission

Refer to Section 308-00.

GENERAL PROCEDURES

Transmission Draining and Filling

Material

Item	Specification
MERCON® V Automatic Transmission Fluid XT-5-QM (or XT-5-QMC) (US); CXT-5-LM12 (Canada)	MERCON® V
Threadlock and Sealer TA-25	WSK-M2G351-A5

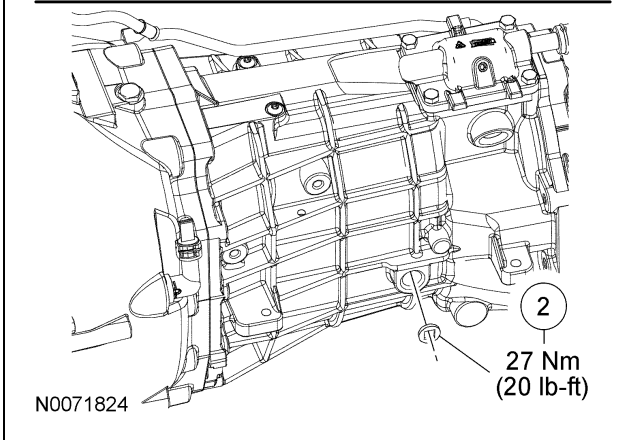
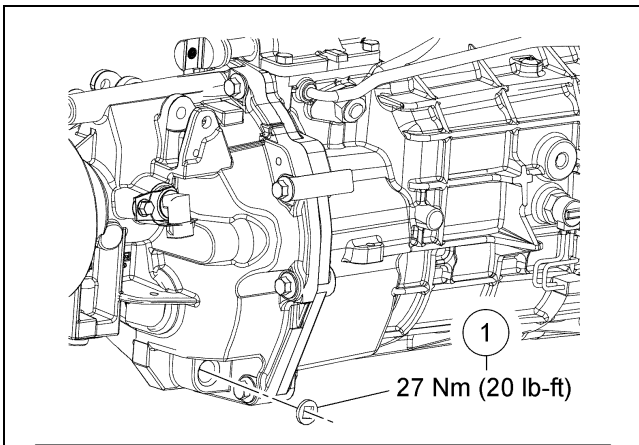

Item	Part Number	Description
1	7A010	Drain plug
2	7A010	Filler plug

1. With the vehicle in NEUTRAL, position it on a hoist. For additional information, refer to Section 100-02.

2. **NOTE:** Position a suitable drain pan under the transmission.
Remove the drain plug and drain the transmission.

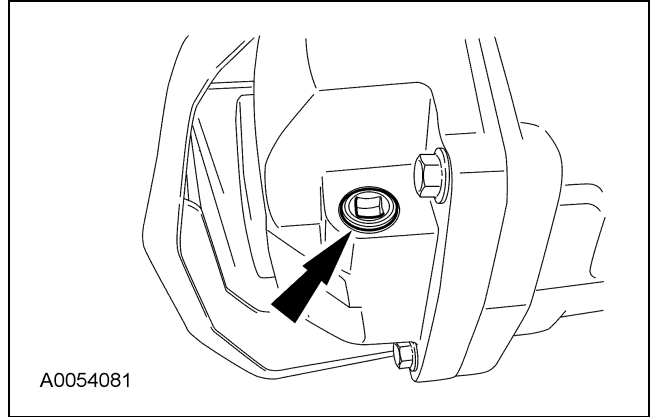

3. Clean the drain plug. Apply threadlock to the plug threads and install the drain plug.
 - Tighten to 27 Nm (20 lb-ft).
4. **NOTE:** Before removing, clean the area around the filler plug.
Remove the filler plug.

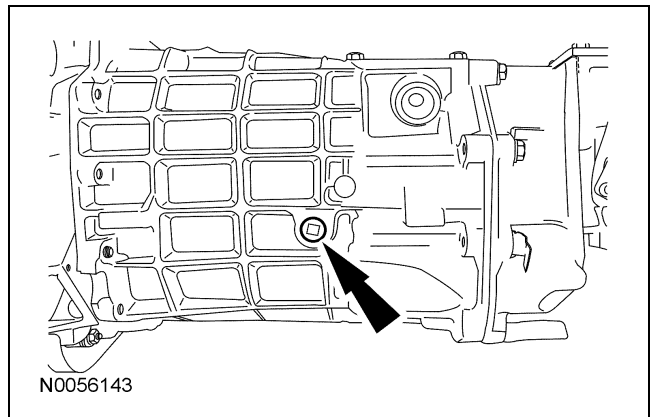

GENERAL PROCEDURES (Continued)

5. Using a suitable oil suction gun, fill the transmission to the correct level with the specified fluid.
 - Transmission capacity is 3.46L (3.65 qt).
6. Apply threadlock to the plug threads and install the filler plug.
 - Tighten to 27 Nm (20 lb-ft).

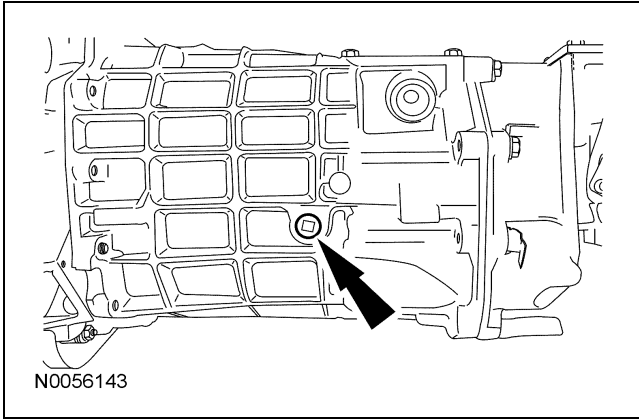

IN-VEHICLE REPAIR

Gearshift Lever

Gearshift Lever Exploded View

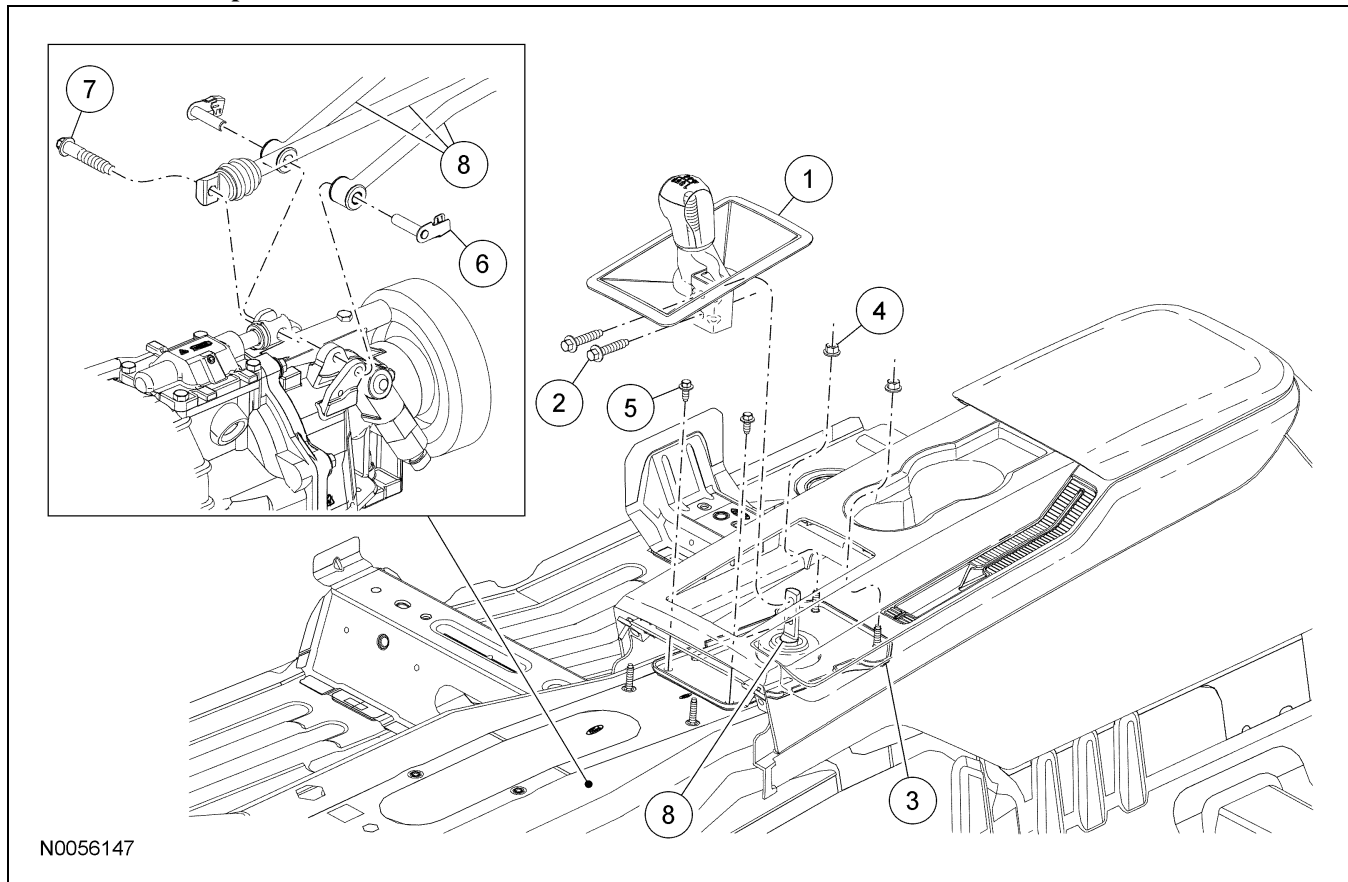

Item	Part Number	Description
1	7C392	Gearshift lever knob and boot
2	—	Gearshift lever bolt (part of 7C392)
3	7Z206	Gearshift lever shield
4	W702751	Gearshift lever shield nut
5	W505424	Gearshift lever shield bolt
6	7314	Gearshift lever retainer
7	W711489	Gearshift lever bolt
8	7400	Gearshift lever assembly

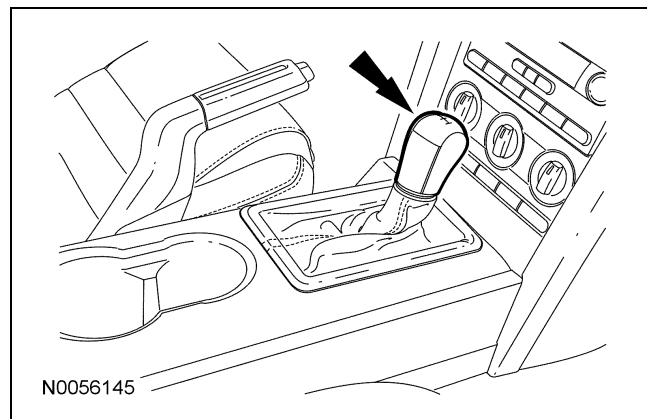

1. Remove the gearshift lever knob and boot.
2. Remove the upper gearshift lever bolts and the upper gearshift lever.
 - To install, tighten to 35 Nm (26 lb-ft).
3. With the vehicle in NEUTRAL, position it on a hoist. For additional information, refer to Section 100-02.

IN-VEHICLE REPAIR (Continued)

4. Remove the driveshaft. For additional information, refer to Section 205-01.
5. Remove the 4 subframe cross brace bolts and the subframe cross brace.
 - To install, tighten to 48 Nm (35 lb-ft).

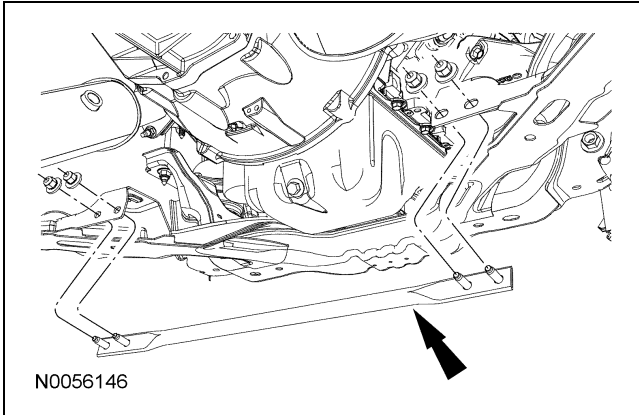

6. Using a suitable transmission jack, support the transmission.
7. Remove the 4 rear transmission mount outer bolts.
 - To install, tighten to 63 Nm (46 lb-ft).
8. Lower the transmission.
9. Remove the 2 rear gearshift lever nuts.

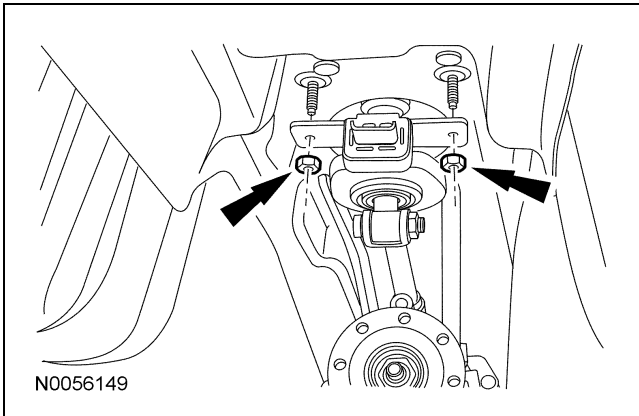

10. Remove the gearshift lever assembly.
 1. Insert a pick into the lower hole to unlock the clip.
 2. Rotate the gearshift lever retainers, then remove the retainers.
 3. Remove the gearshift lever bolt.
 4. Remove the gearshift lever assembly from the vehicle.
 - To install, tighten to 40 Nm (30 lb-ft).

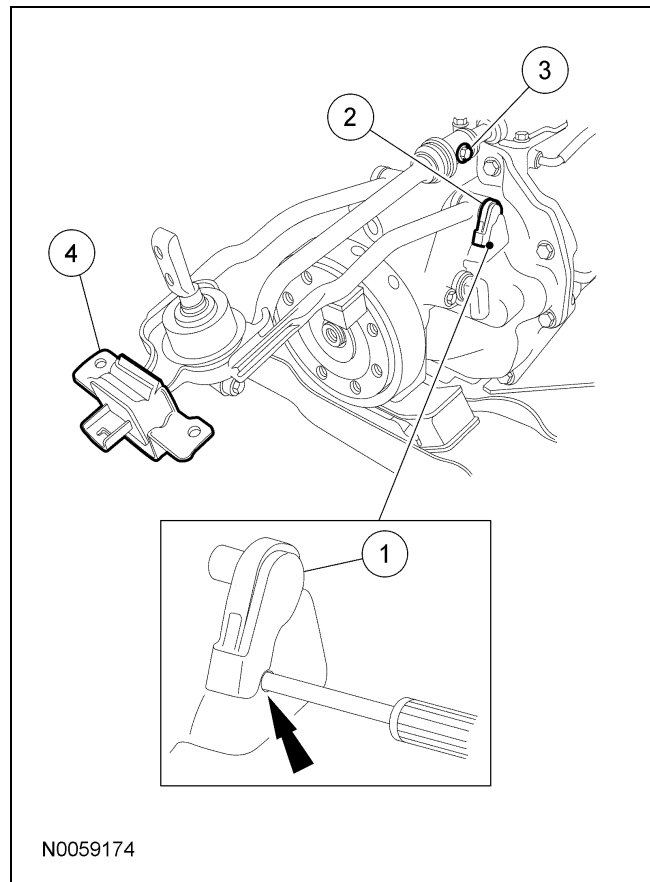

IN-VEHICLE REPAIR (Continued)

11. To install, reverse the removal procedure.
- Make sure to snap the gearshift lever retainers into the locked position.
 - Carefully position the gearshift lever into the lower shift boot. Make sure the lever is through the boot.

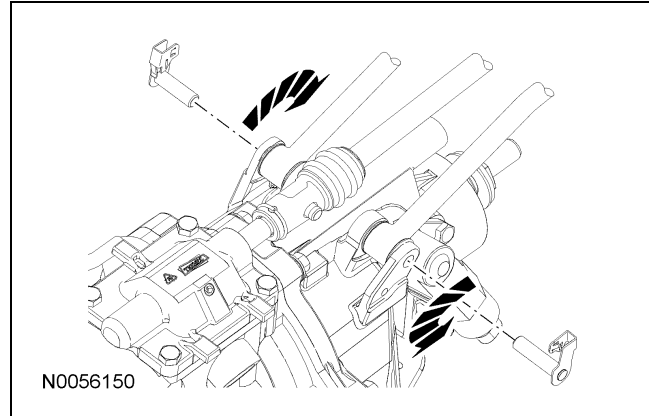

IN-VEHICLE REPAIR

Transmission Rear Support Insulator

Transmission Rear Support Insulator Exploded View

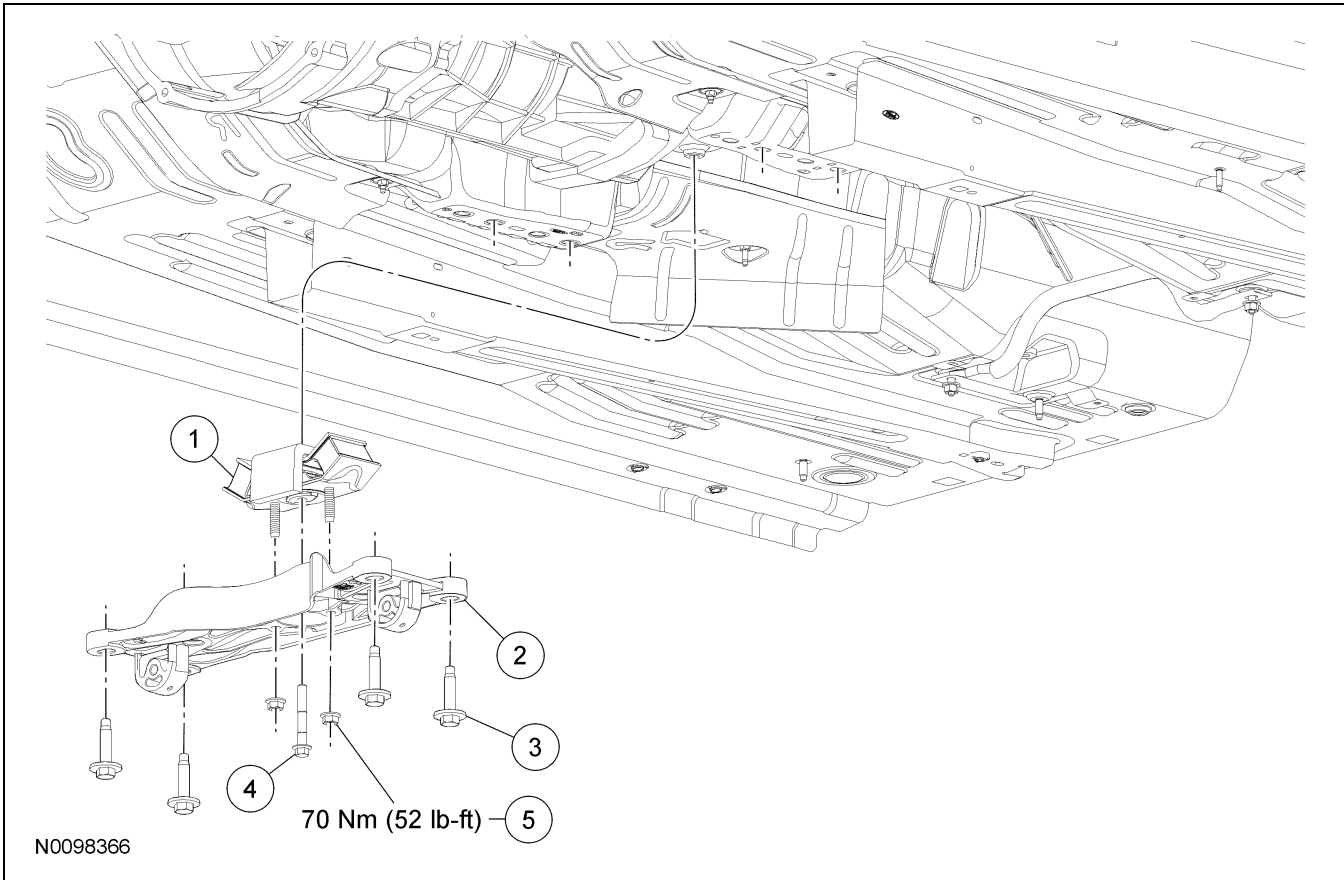

Item	Part Number	Description
1	6068	Transmission support insulator
2	6068	Transmission mount
3	W505466	Transmission mount outer bolt (4 required)
4	N804518	Transmission support insulator center bolt
5	—	Transmission support insulator nut (2 required)

1. With the vehicle in NEUTRAL, position it on a hoist. For additional information, refer to Section 100-02.

2. **NOTE:** Take note that the crossmember hump side goes up.
Remove the transmission crossmember. For additional information, refer to Section 502-00.
3. Remove the 2 transmission rear support insulator nuts. Separate the transmission rear support insulator from the transmission mount.
 - To install, tighten to 70 Nm (52 lb-ft).
4. To install, reverse the removal procedure.

REMOVAL AND INSTALLATION

Transmission

1. With the vehicle in NEUTRAL, position it on a hoist. For additional information, refer to Section 100-02.
2. Disconnect the battery ground cable. For additional information, refer to Section 414-01.
3. Remove the gearshift lever knob and boot.

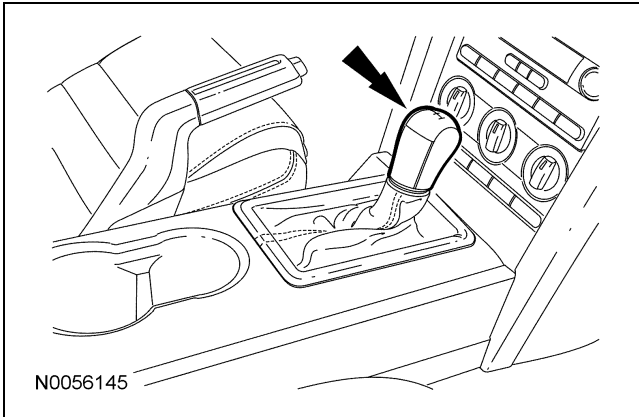

4. Remove the upper gearshift lever bolts and the upper gearshift lever.
5. Remove the driveshaft. For additional information, refer to Section 205-01.
6. Remove the catalytic converter assembly (H-pipe). For additional information, refer to Section 309-00.
7. Remove the starter motor. For additional information, refer to Section 303-06.
8. Remove the 4 subframe cross brace bolts and the subframe cross brace.

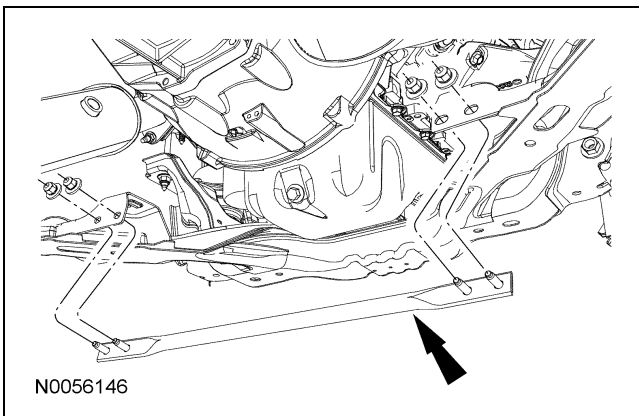

9. Disconnect the electrical connectors from the LH side of the transmission. Detach the harness from the transmission and position it aside.
10. Disconnect the electrical connectors from the RH side of the transmission. Detach the harness from the transmission and position it aside.
11. Release the clutch hydraulic tube clip and separate the clutch hydraulic tube from the connector.

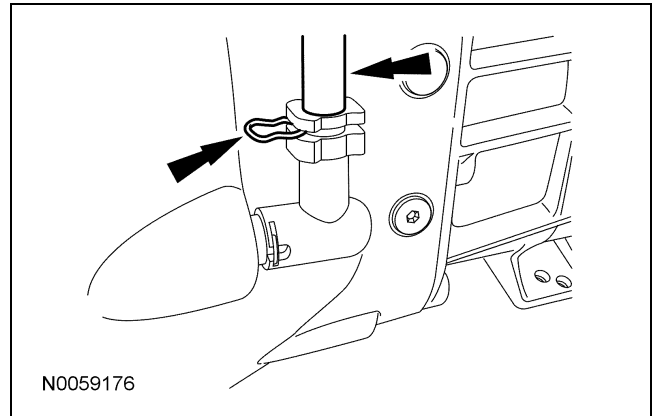

12. If transmission disassembly is necessary, drain the transmission fluid.
13. **NOTE:** Take note that the crossmember hump side goes up.
Remove the transmission crossmember. For additional information, refer to Section 502-00.

REMOVAL AND INSTALLATION (Continued)

14. **NOTE:** Make sure the block of wood is only on the pan rail.

Disconnect the wire harness at the front of the engine oil pan. Using an under hoist stand and a block of wood, raise the engine to pivot the transmission downward. This provides clearance between the input shaft and clutch pressure plate fingers.

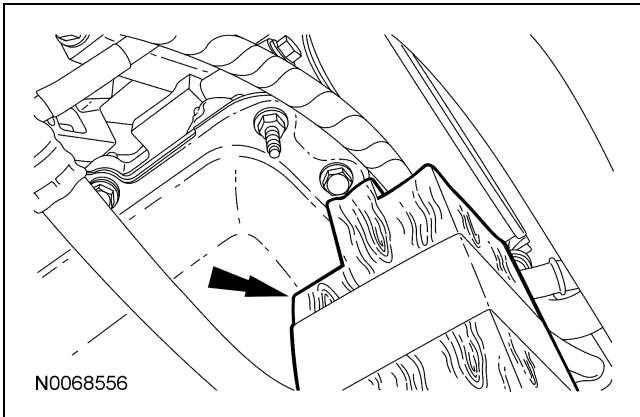

15. Lower the transmission.

16. Remove the 2 rear gearshift lever nuts.

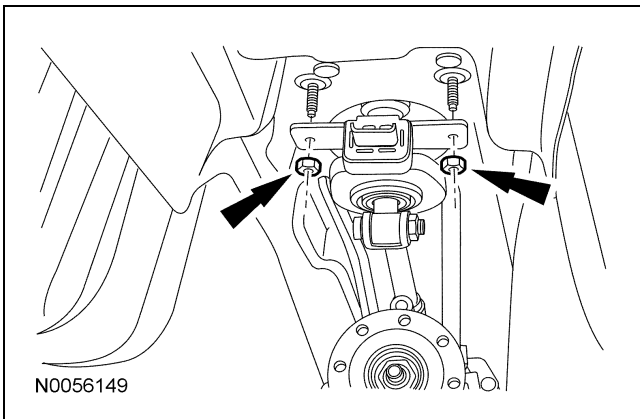

17. Remove the 7 transmission-to-engine bolts.

18. Using the transmission mount, rotate the transmission 45 degrees clockwise. Pull the transmission rearward until the input shaft is clear of the pressure plate, then lower the transmission from the vehicle.

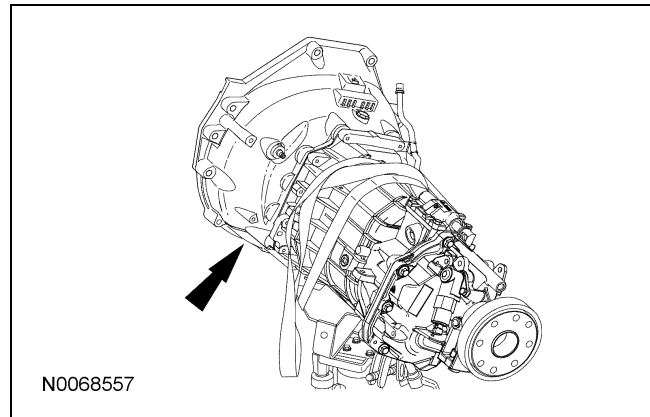

19. If necessary, remove the rear transmission insulator center bolt and the transmission mount.

REMOVAL AND INSTALLATION (Continued)

20. If necessary, remove the gearshift lever assembly.
- 1 Insert a pick into the lower hole to unlock the clip.
 - 2 Rotate the gearshift lever retainers, then remove the retainers.
 - 3 Remove the gearshift lever bolt.
 - 4 Remove the gearshift lever assembly.
- To install, tighten to 40 Nm (30 lb-ft).

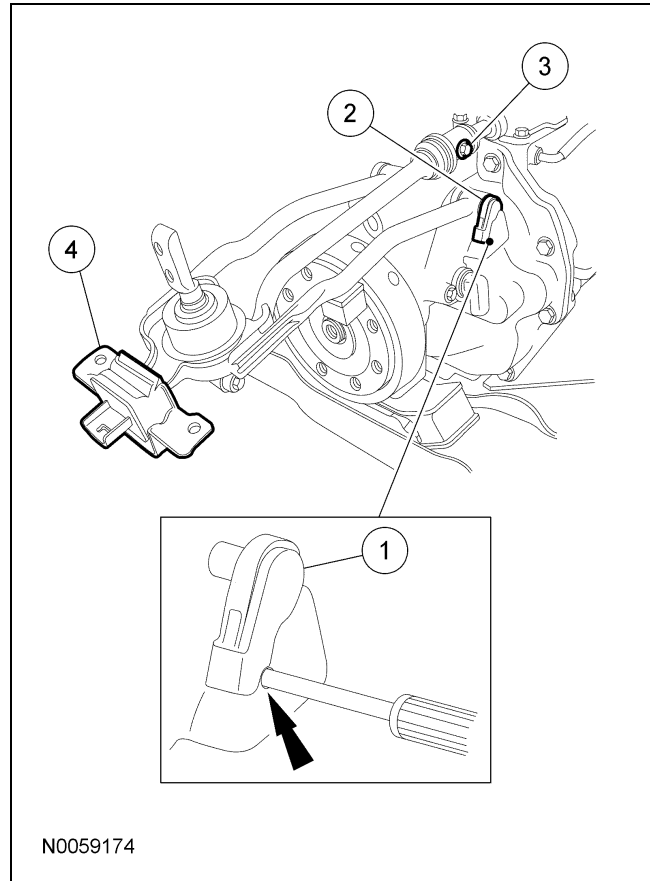

DISASSEMBLY AND ASSEMBLY

Transmission

Special Tool(s)

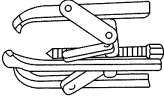
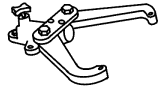
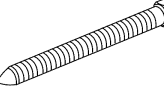
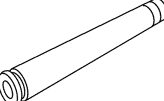
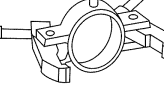
 <p>ST1184-A</p>	<p>2- or 3-Jaw Puller 205-D027 (D80L-1013-A)</p>
 <p>ST1186-A</p>	<p>Holding Fixture, Transmission 307-003 (T57L-500-B)</p>
 <p>ST1304-A</p>	<p>Removal Screw, Bearing Tube 308-092 (T84T-7025-B)</p>
 <p>ST2163-A</p>	<p>Remover/Installer, Bearing Tube 308-024 (T75L-7025-B)</p>
 <p>ST1305-A</p>	<p>Remover, Mainshaft Bearing 308-058 (T77J-7025-H)</p>

(Continued)

Special Tool(s)

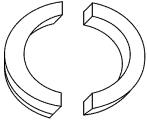
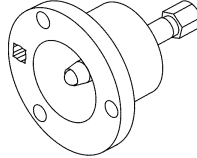
 <p>ST1306-A</p>	<p>Remover, Mainshaft Bearing 308-059 (T77J-7025-J)</p>
 <p>ST2415-A</p>	<p>Remover, Output Shaft Flange 307-523</p>

Disassembly

NOTE: During disassembly, if any roll pins, retaining rings or bearings are removed, install new components. Install bearings and bearing cups as a set only.

NOTE: For additional information, refer to the exploded view under the assembly procedure in this section.

1. Clean the transmission exterior with solvent and dry with compressed air. During disassembly, clean all components with solvent and dry with compressed air.
2. Remove the 2 clutch slave cylinder bolts and the clutch slave cylinder.

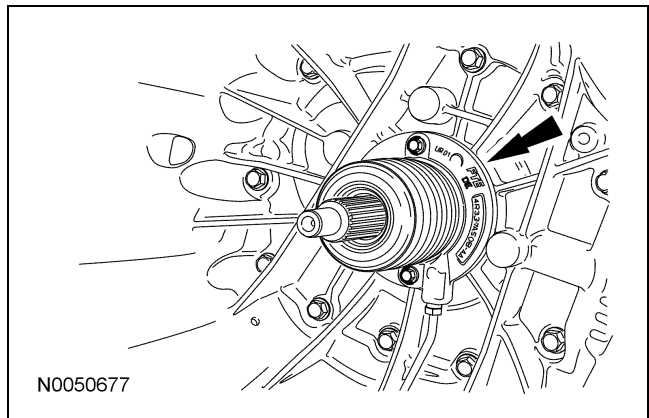

3. Remove the clutch hydraulic tube clip and the clutch hydraulic tube connector.

DISASSEMBLY AND ASSEMBLY (Continued)

4. Attach the transmission to the Transmission Holding Fixture.

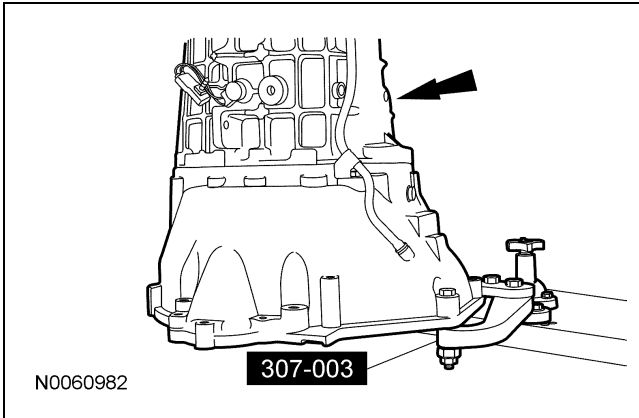

8. Using the Output Shaft Flange Remover, remove the output shaft flange.

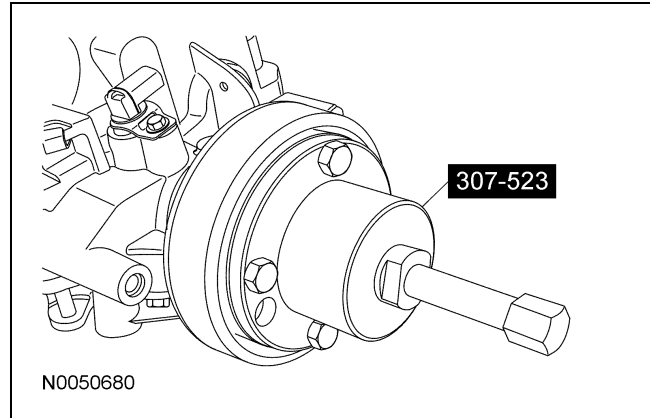

5. Rotate the transmission to a horizontal position.

6. **NOTE:** Position a drain pan under the transmission.

If the transmission was not drained during removal, remove the drain plug and drain the transmission.

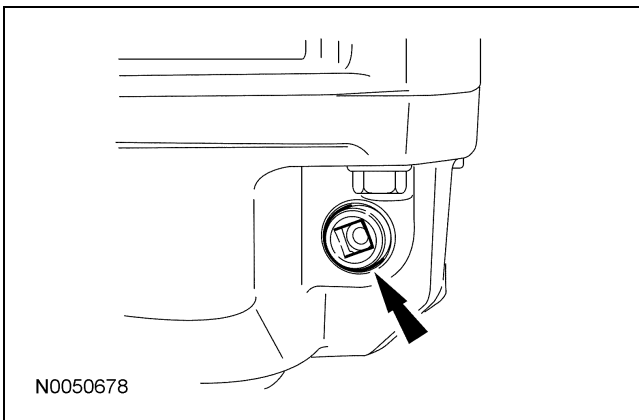

9. Remove the 4 bolts and the shift detent cover.

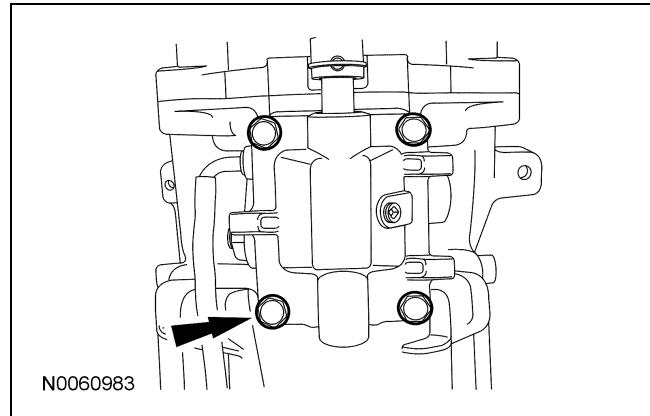

7. Remove the output shaft flange nut.

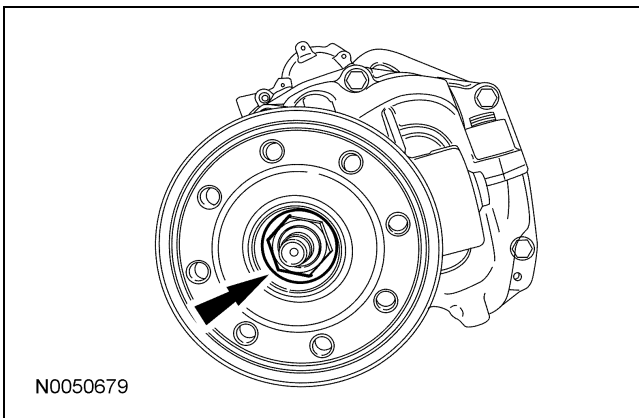

10. Rotate the transmission to a vertical position.

11. Remove the 8 bolts and carefully separate the extension housing from the transmission.

12. Using a 2- or 3-Jaw Puller, remove the bearing race and the spacer.

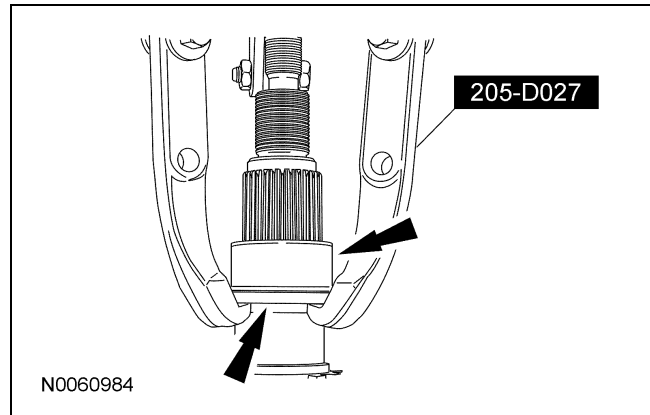

DISASSEMBLY AND ASSEMBLY (Continued)

13. Remove and discard the Output Shaft Speed (OSS) sensor tone wheel snap ring.

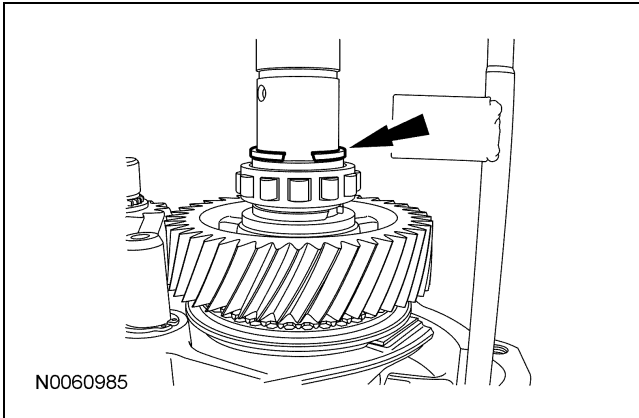

14. Remove the tone wheel and the ball.

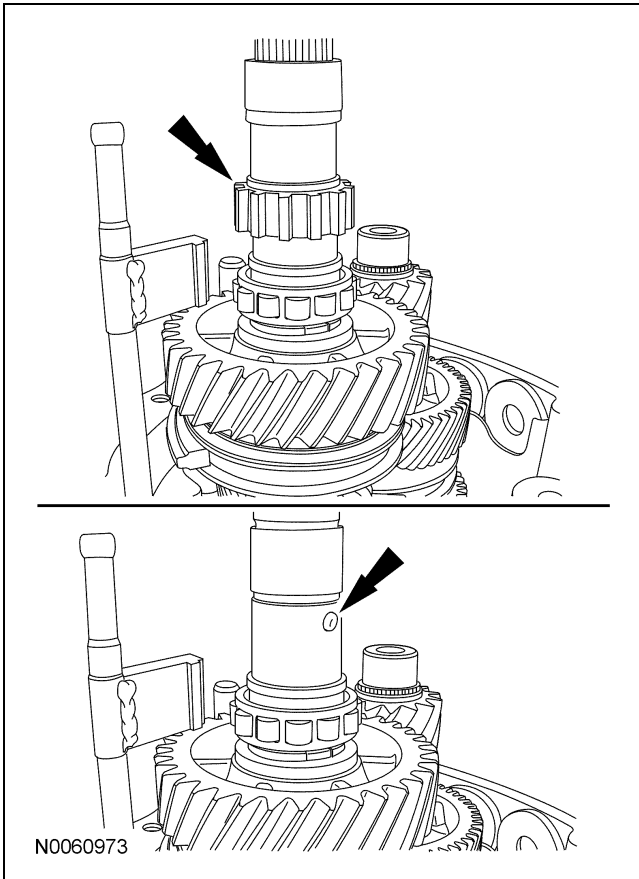

15. Remove and discard the snap ring, the upper spacer, the rear output shaft roller bearing and the lower spacer.

- Inspect the rear output shaft roller bearing for wear or damage. Install a new bearing as necessary.

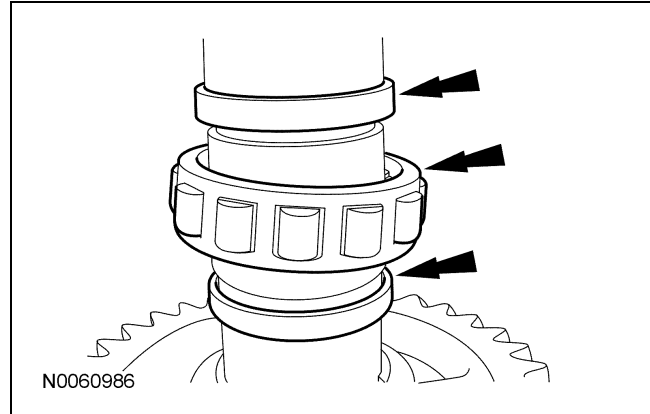

16. **NOTE:** Position the gearshift lever in 3rd/4th neutral position.

Using a 5/32-inch drift and a hammer, drive the roll pins downward, then remove the reverse shift rail.

- Discard the roll pins.

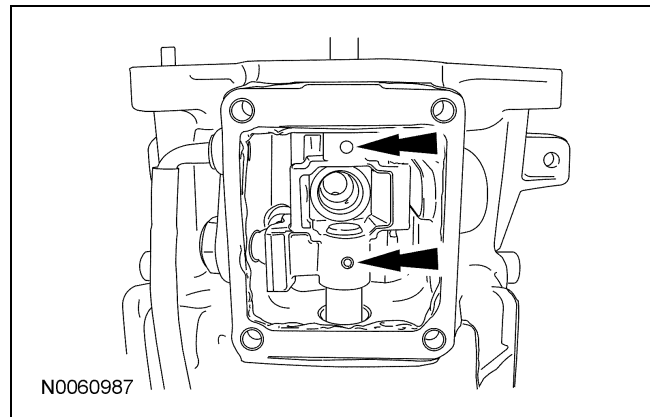

DISASSEMBLY AND ASSEMBLY (Continued)

17. Remove the following:

- 1 The reverse gear snap ring.
 - 2 The reverse gear thrust washer.
 - 3 The reverse gear.
- Discard the reverse gear snap ring.
 - Inspect reverse gear for wear or damage. Install a new gear as necessary.

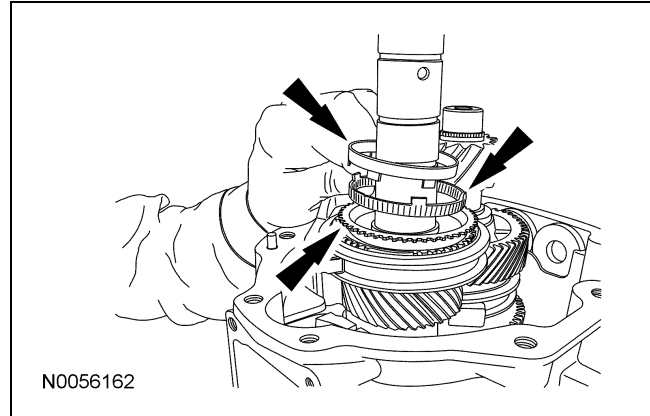
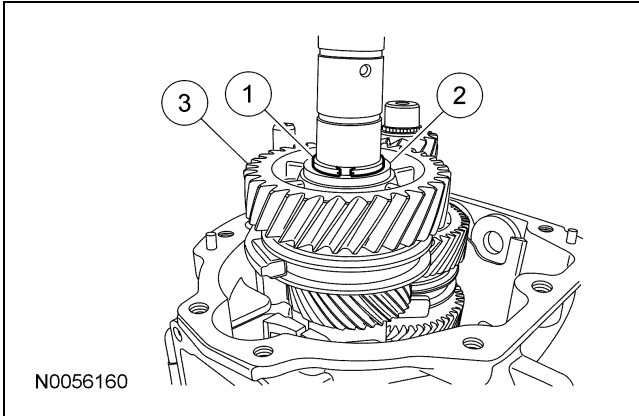

20. Remove and discard the reverse gear synchronizer snap ring.

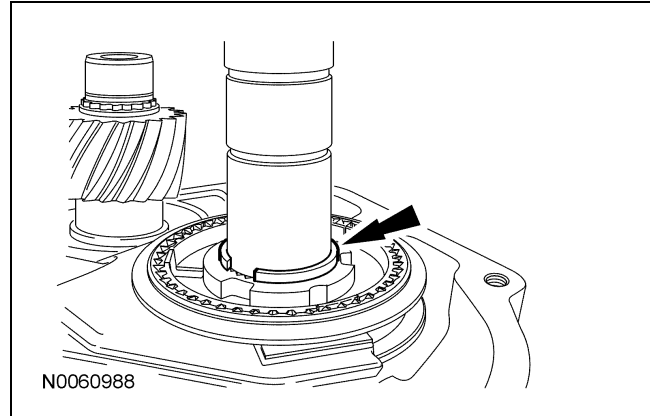

18. Remove the reverse gear needle bearing.

- Inspect the needle bearing for wear or damage. Install a new bearing as necessary.

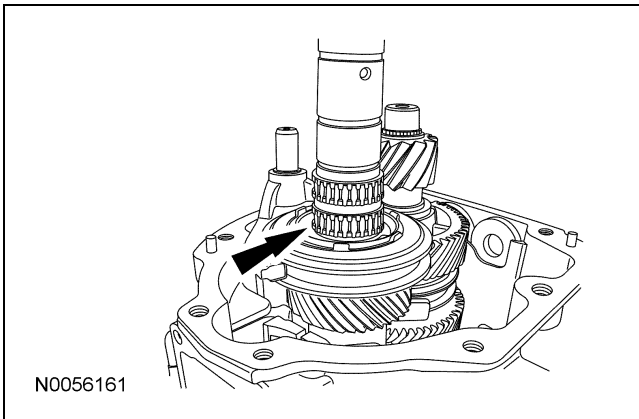

21. Remove and discard the reverse shift fork snap ring.

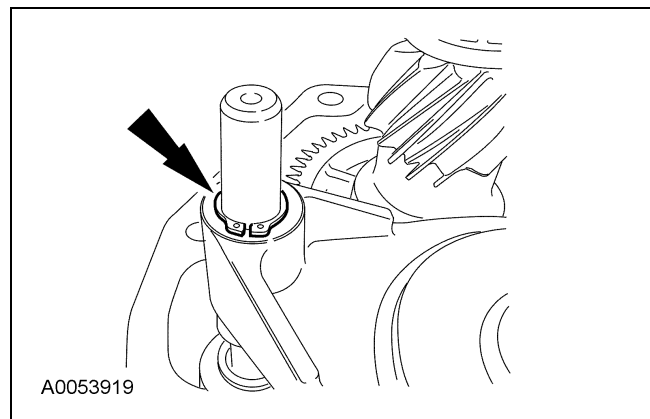

19. Remove the 3 piece reverse gear synchronizer blocking ring.

DISASSEMBLY AND ASSEMBLY (Continued)

22. Remove the reverse shift fork and the reverse synchronizer.

- The synchronizer hub is a tight fit on the shaft, and may need to be removed separately. After removing the fork and synchronizer sleeve, carefully pry off the synchronizer hub.

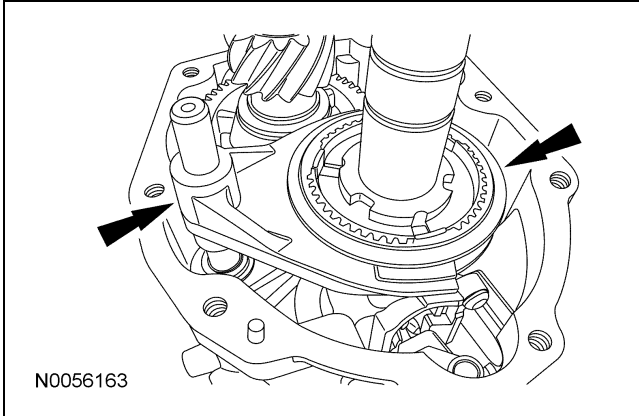

23. Inspect the synchronizer for the following:

- Check for worn, nicked or broken teeth. Install a new synchronizer as necessary.
- Check keys for wear or distortion. Check the springs for distortion. Install a new synchronizer as necessary.

24. Inspect the synchronizer blocking ring for the following:

- Check for wear or damage. Install a new synchronizer blocking ring as necessary.
- Check the clearance between the synchronizer blocking ring and the gear.
 - Position the blocking ring onto the gear. Make sure the correct blocking ring is measured with the correct gear and that the blocking ring is fully seated on the gear.
 - Insert a feeler gauge and measure the clearance while applying pressure and rotating the blocking ring. The measurement should be the same around the entire circumference. If the clearance is less than 0.75 mm (0.030 in), install new blocking ring.

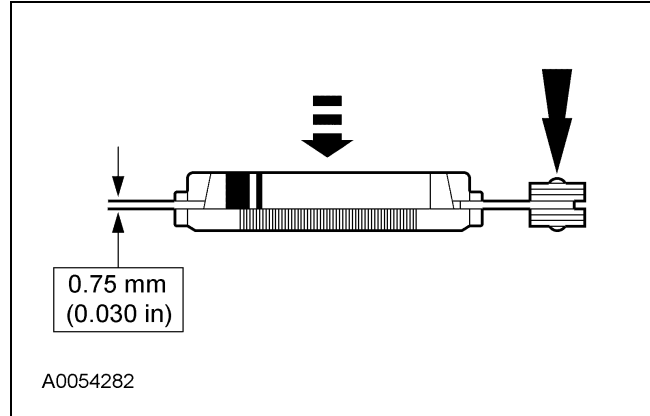

25. Remove the 5th driven gear split ring and retainer.

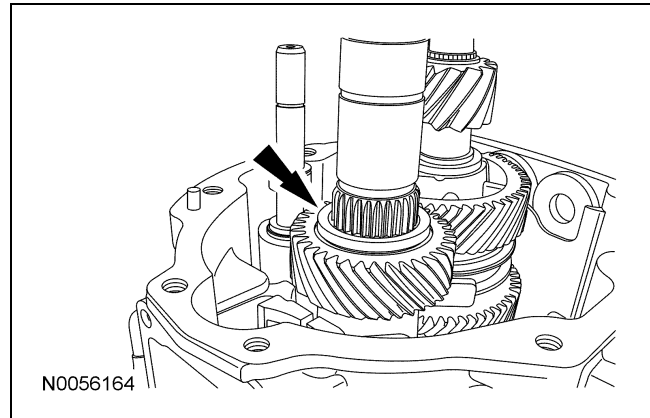

DISASSEMBLY AND ASSEMBLY (Continued)

26. Using the Bearing Tube Removal Screw, Bearing Tube Remover/Installer and the Mainshaft Bearing Remover, remove the 5th driven gear.

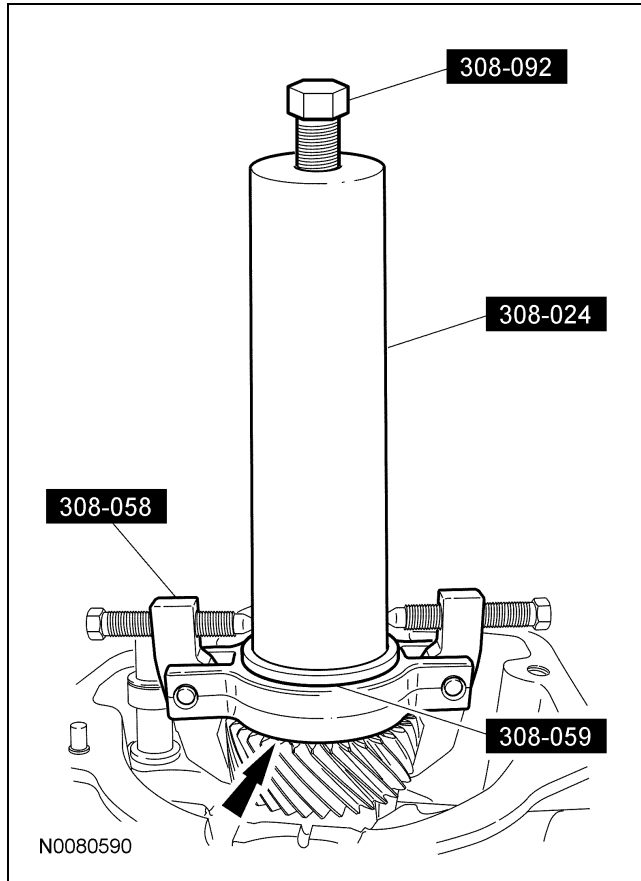

27. Remove the 5th/6th shift fork snap ring.
- Discard the snap ring.

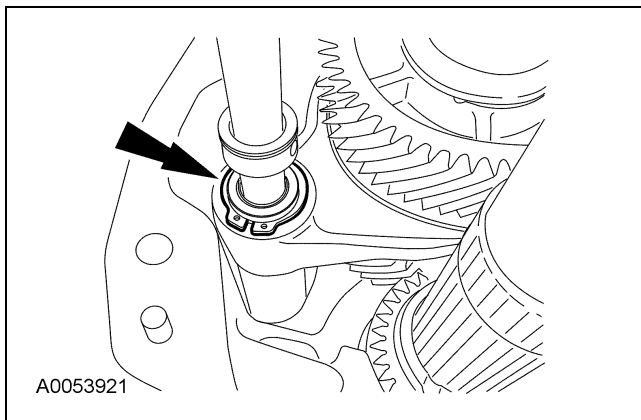

28. Remove the reverse drive gear snap ring.
- Discard the snap ring.

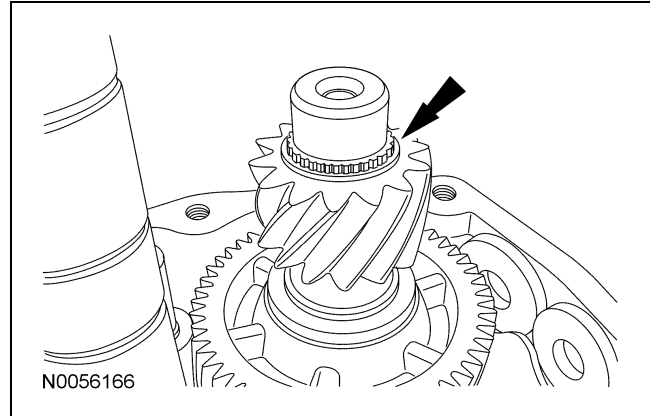

29. Using a suitable puller, remove the reverse drive gear.
- Inspect reverse drive gear for wear or damage. Install a new gear as necessary.

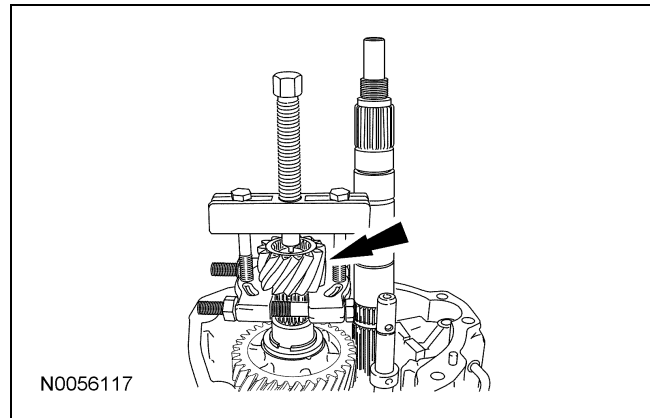

30. Remove the following:

- 1 The 5th drive gear snap ring.
 - 2 The 5th drive gear thrust washer.
 - 3 The 5th drive gear.
- Discard the snap ring.
 - Inspect the 5th drive gear for wear or damage. Install a new gear as necessary.

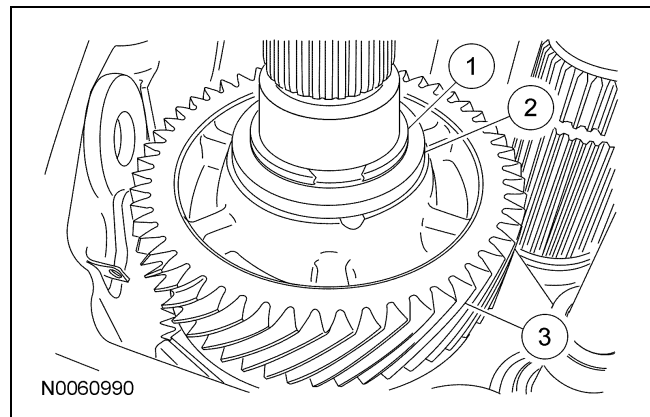

DISASSEMBLY AND ASSEMBLY (Continued)

31. Remove the 5th/6th drive gear needle bearing and spacer.

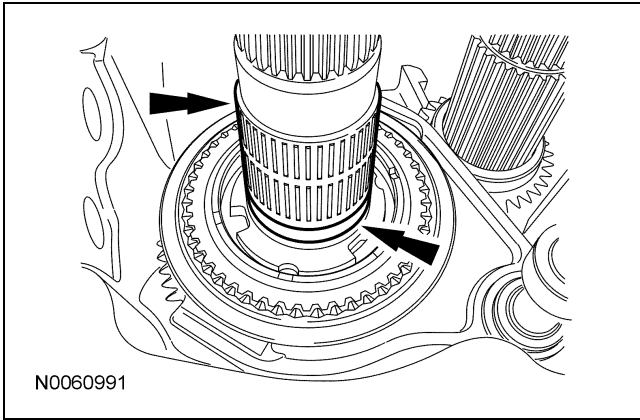

32. Remove the 5th/6th gear synchronizer intermediate cone, the 5th/6th gear synchronizer outer cone and the 5th/6th gear synchronizer blocking ring.

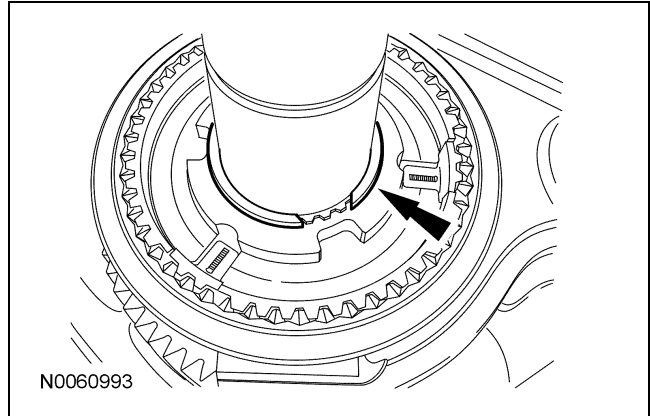
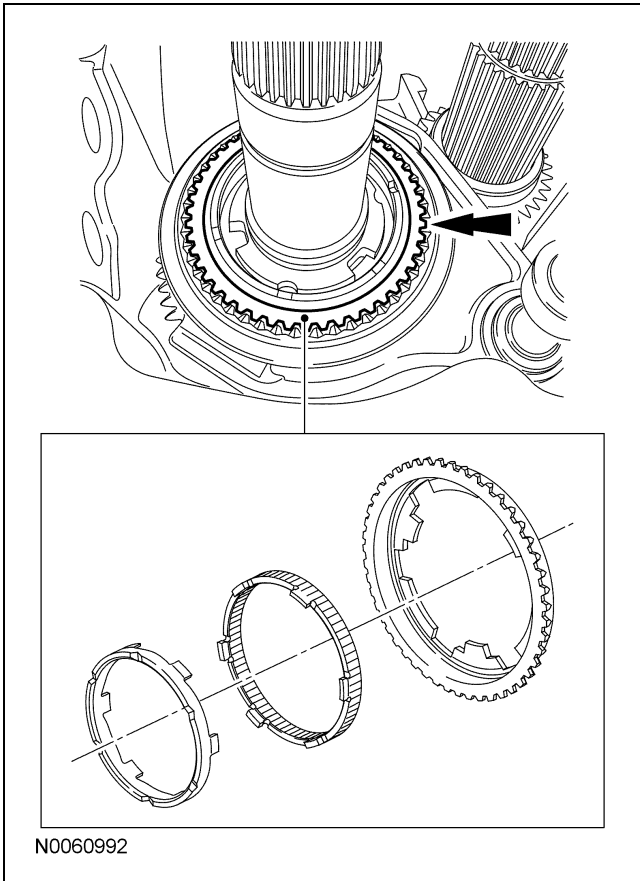

34. Remove the 5th/6th gear shift fork and 5th/6th gear synchronizer.

- The synchronizer hub is a tight fit on the shaft, and may need to be removed separately. Using a 2- or 3-Jaw Puller, remove the synchronizer hub.

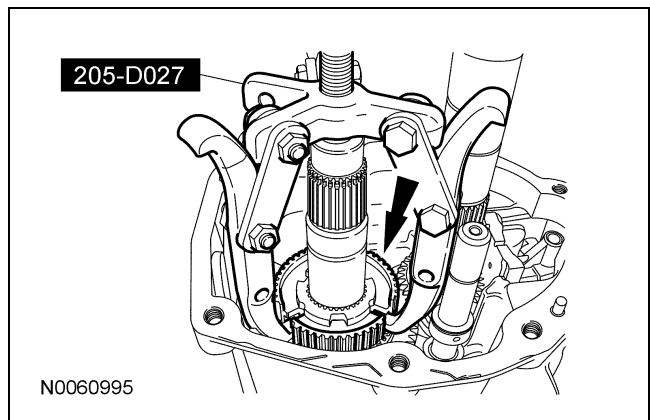
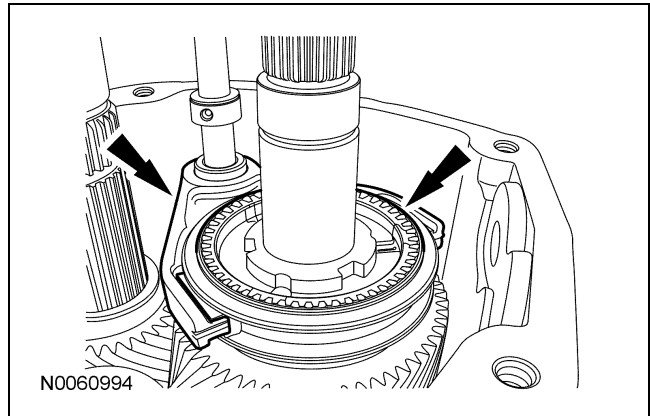

33. Remove the snap ring.

DISASSEMBLY AND ASSEMBLY (Continued)

35. Remove the 5th/6th gear synchronizer intermediate cone, the 5th/6th gear synchronizer outer cone and the 5th/6th gear synchronizer blocking ring.

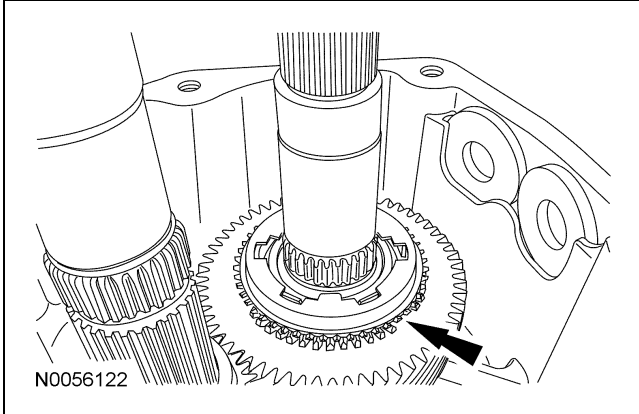

36. Remove 6th gear.

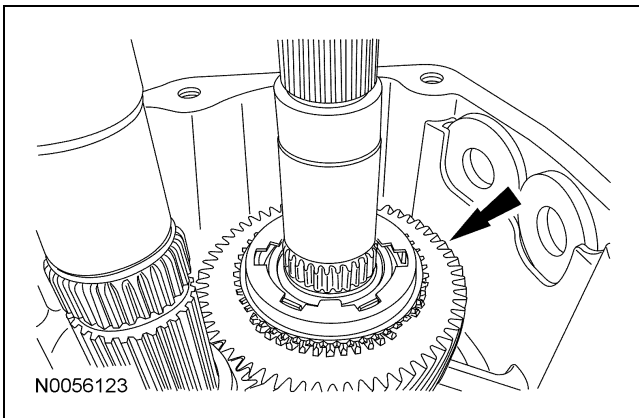

37. Remove the 6th gear needle bearing.

38. Remove 9 of the transmission main case-to-clutch housing bolts.

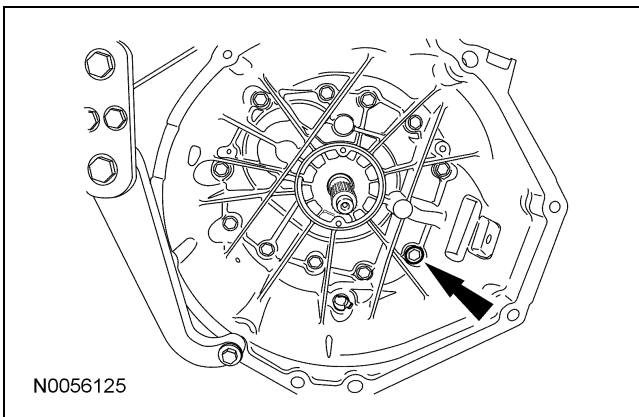

39. Remove the vent hose.

40. **NOTE:** Rotate the transmission to a vertical position.

Remove the 2 shift lever guide bolts.

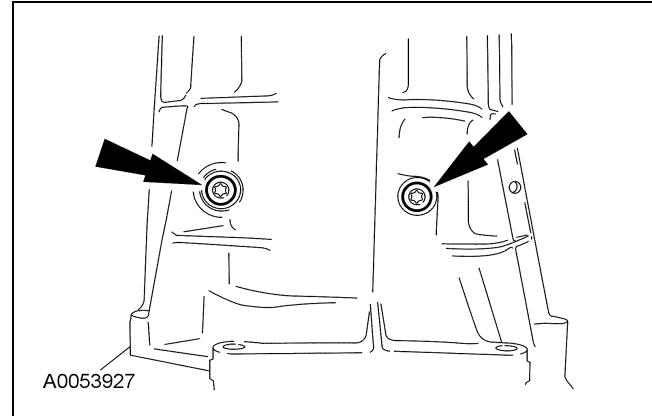

41. Remove the 5th/6th and reverse shift lever detent bolt, spring and detent.

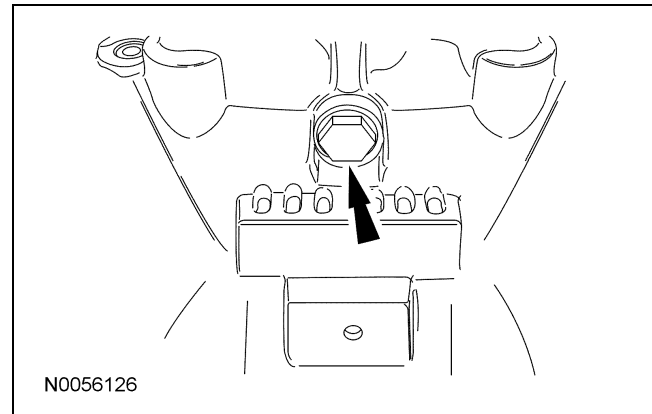

42. Remove the 2 remaining transmission main case-to-clutch housing bolts, then remove the transmission case and the front offset lever.

- Slide the transmission case upward, off the output shaft and shift rails. Hold the offset lever against the guide plate.

DISASSEMBLY AND ASSEMBLY (Continued)

43. Remove the 6th gear spacer and thrust washer.

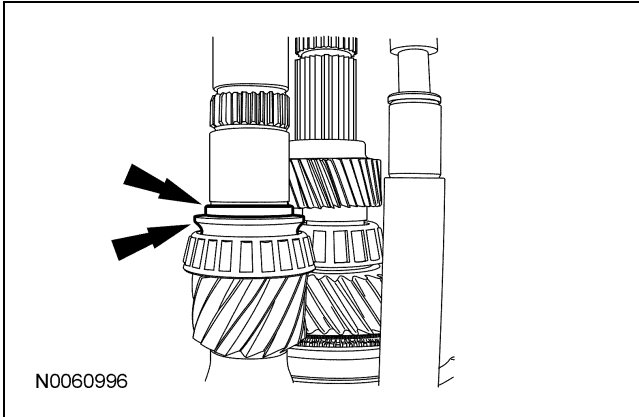

44. Rotate the 5th/6th and reverse shift levers from the shift interlock plate, then remove the 5th/6th and reverse shift rail assembly.

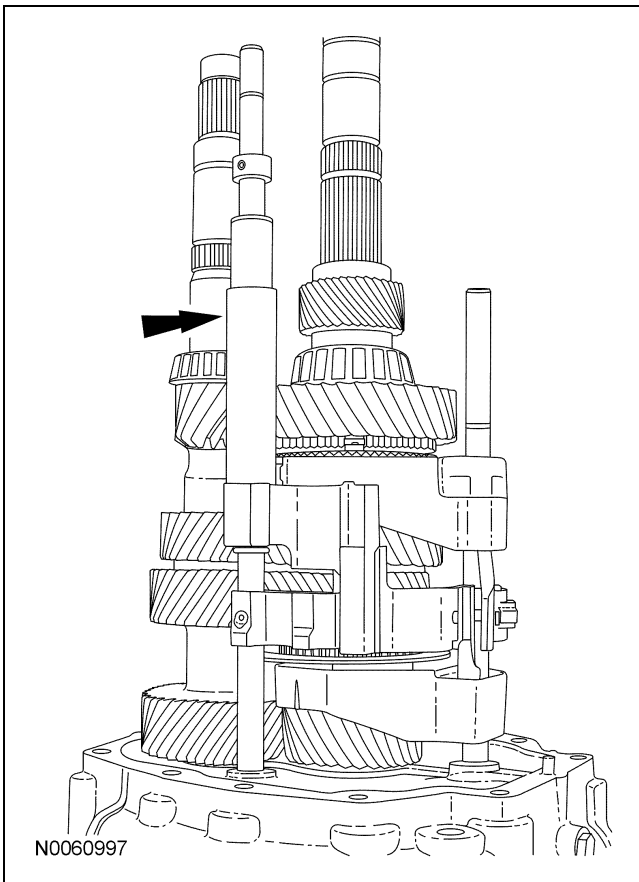

45. Lift up the output shaft, then remove the countershaft.

46. Remove the output shaft and shift rail as an assembly. Separate the shift rail assembly from the output shaft on the work bench.

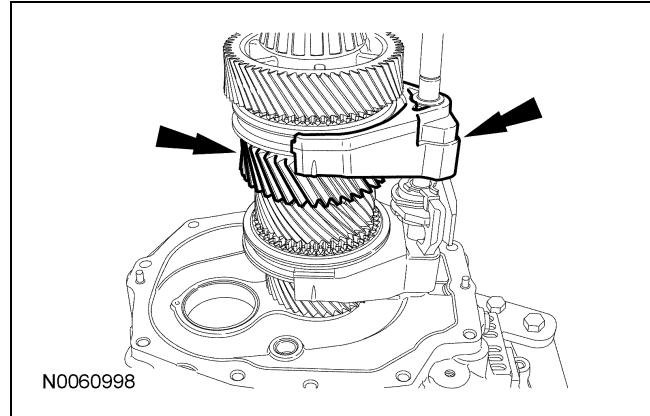

47. Remove the input shaft, the 4th gear synchronizer blocking ring and the double cone (3 rings).

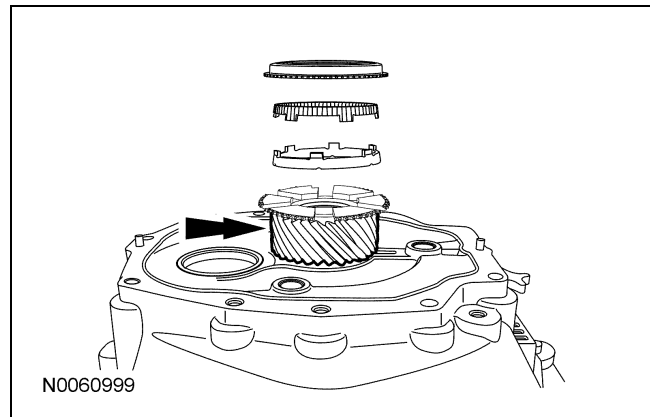

48. Remove the countershaft bearing cup and the countershaft shim.

- Inspect the cup for wear or damage. Install a new cup and bearing as necessary.
- Inspect the cup bore for wear, scratches or grooves. Install a new transmission adapter plate as necessary.

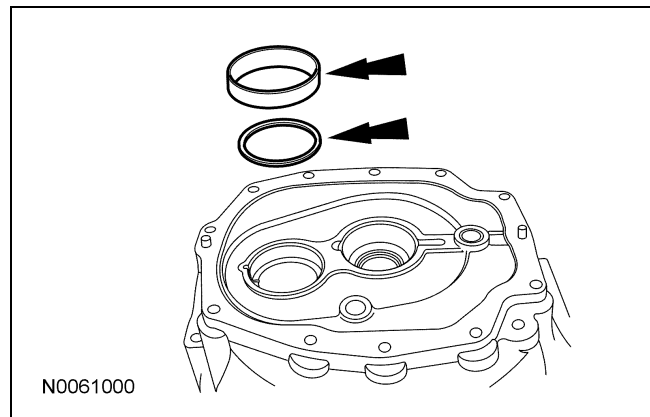

DISASSEMBLY AND ASSEMBLY (Continued)

49. Remove the input shaft bearing cup and input shaft shim.
- Inspect the cup for wear or damage. Install a new cup and bearing as necessary.
 - Inspect the cup bore for wear, scratches or grooves. Install a new transmission adapter plate as necessary.

50. Remove and discard the input shaft seal.
51. Inspect the clutch housing for cracks. Clean and check the sealing surface for nicks or scratches.
- If the clutch housing is cracked, install a new housing. If the sealing surface has nicks or scratches, use a soft stone or crocus cloth to remove.

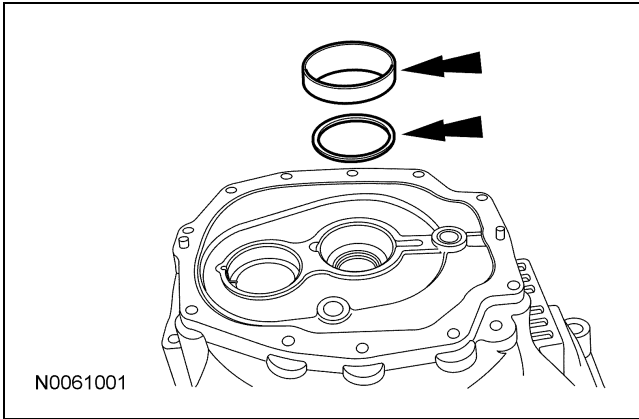

DISASSEMBLY AND ASSEMBLY

Input Shaft and Bearing

Special Tool(s)

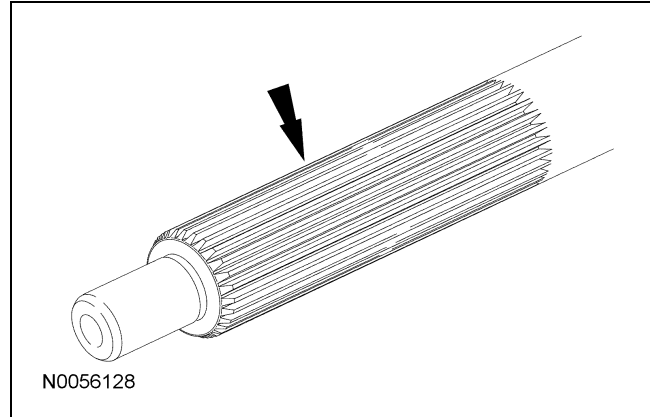
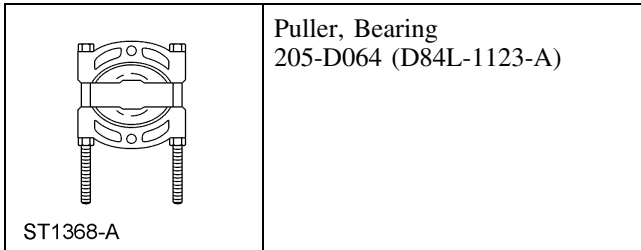

Disassembly and Assembly

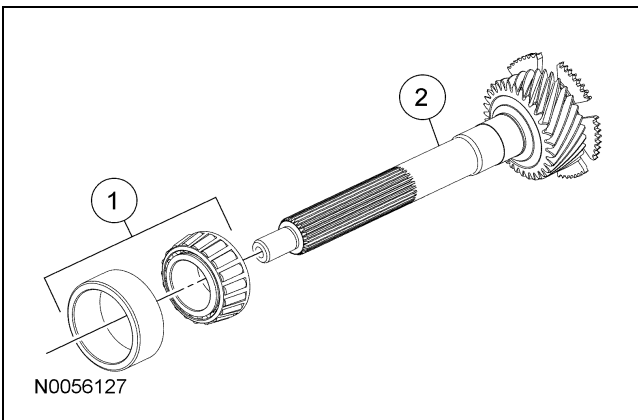

- Using the Bearing Puller and a press, remove the input shaft front bearing.

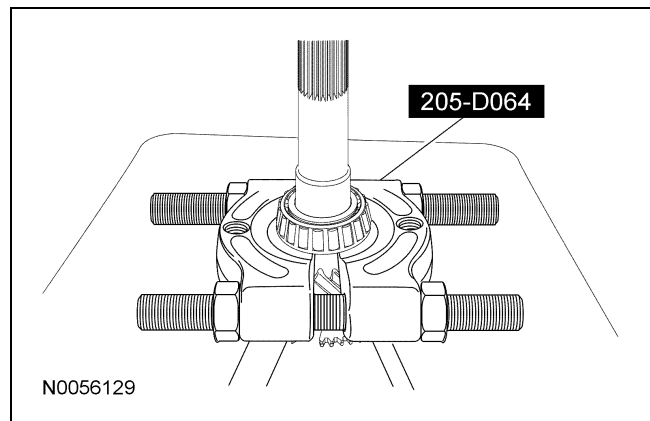

Item	Part Number	Description
1	7025	Input shaft bearing
2	7017	Input shaft

- Using the Bearing Puller and a press, install a new input shaft bearing.

- NOTE:** Any wear or damage on the input shaft can prevent the clutch from operating correctly. Inspect the splines on the input shaft for wear or damage. If worn or damaged, install a new input shaft.

 - Use an emery cloth to remove small scratches.

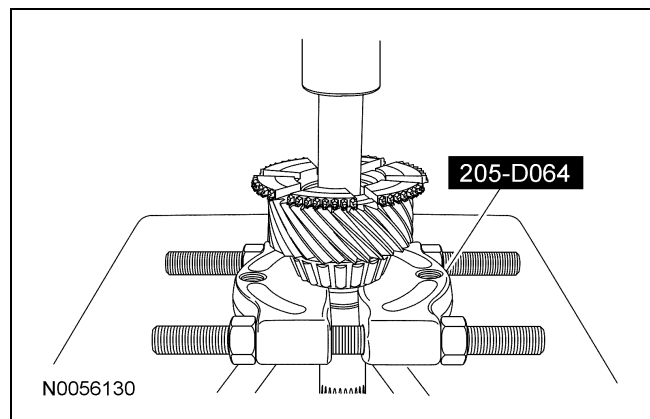

DISASSEMBLY AND ASSEMBLY

Output Shaft

Special Tool(s)

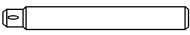
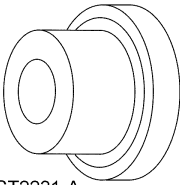
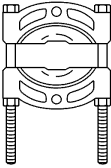
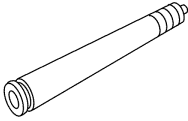
 ST1255-A	Adapter for 303-224 (Handle) 205-153 (T80T-4000-W)
 ST2231-A	Installer, Output Shaft Rear Bearing 308-401
 ST1368-A	Puller, Bearing 205-D064 (D84L-1123-A)
 ST2163-A	Remover/Installer, Bearing Tube 308-025 (T75L-7025-C)

Material

Item	Specification
MERCON® V Automatic Transmission Fluid XT-5-QM (or XT-5-QMC) (US); CXT-5-LM12 (Canada)	MERCON® V

DISASSEMBLY AND ASSEMBLY (Continued)

Disassembly

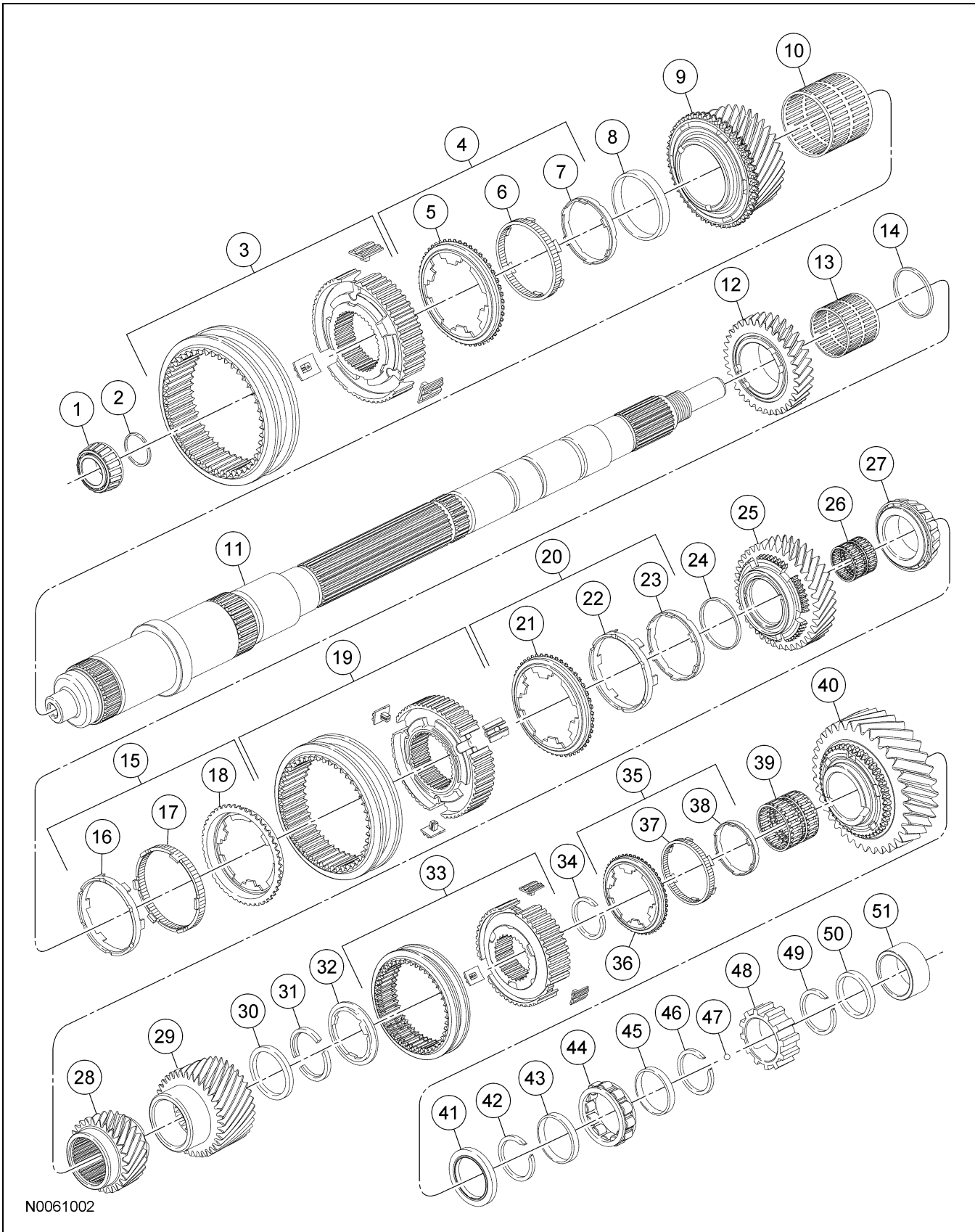

DISASSEMBLY AND ASSEMBLY (Continued)

Item	Part Number	Description
1	7025	Output shaft front bearing
2	7A082	Snap ring
3	7124	3rd/4th synchronizer assembly
4	7107	3rd/4th synchronizer blocking ring assembly
5	—	Synchronizer blocking ring (part of 7107)
6	—	Synchronizer outer cone (part of 7107)
7	—	Synchronizer inner cone (part of 7107)
8	7117	Spacer
9	7B340	3rd gear
10	7025	3rd gear needle bearing
11	7061	Output shaft
12	7102	2nd gear
13	7025	2nd gear needle bearing
14	7117	Spacer
15	7107	2nd gear synchronizer blocking ring assembly
16	—	Synchronizer inner cone (part of 7107)
17	—	Synchronizer outer cone (part of 7107)
18	—	Synchronizer blocking ring (part of 7107)
19	7124	1st/2nd synchronizer assembly
20	7107	1st gear synchronizer blocking ring assembly
21	—	Synchronizer blocking ring (part of 7107)
22	—	Synchronizer outer cone (part of 7107)
23	—	Synchronizer inner cone (part of 7107)
24	7117	Spacer

(Continued)

Item	Part Number	Description
25	7100	1st gear
26	7025	1st gear needle bearing
27	7025	Output shaft rear bearing
28	7L047	6th driven gear
29	7K316	5th driven gear
30	7A385	Thrust washer
31	—	Split washer
32	—	Synchronizer cone (part of 7107)
33	7124	Reverse synchronizer assembly
34	7A082	Snap ring
35	7107	Reverse gear synchronizer blocking ring assembly
36	—	Synchronizer blocking ring (part of 7107)
37	—	Synchronizer outer cone (part of 7107)
38	—	Synchronizer inner cone (part of 7107)
39	7N168	Reverse gear needle bearing
40	7C238	Reverse gear
41	7A385	Thrust washer
42	7A082	Snap ring
43	—	Spacer
44	7025	Rear output shaft bearing
45	—	Spacer
46	7A082	Snap ring
47	7E172	Check ball
48	7H150	Speedometer rotor
49	7A082	Snap ring
50	—	Spacer
51	—	Output shaft bearing race

1. Remove the 3rd/4th synchronizer sleeve.

DISASSEMBLY AND ASSEMBLY (Continued)

2. **NOTICE:** Hand tighten the special tool to prevent gear damage.

NOTICE: Support the output shaft while using the press to prevent damage to the shaft or gears.

Using the Bearing Puller and a press, remove 1st gear, the output shaft rear bearing and the 5th driven gear.

- Discard the output shaft bearing.
- Inspect the gears for wear or damage. Install a new gear as necessary.

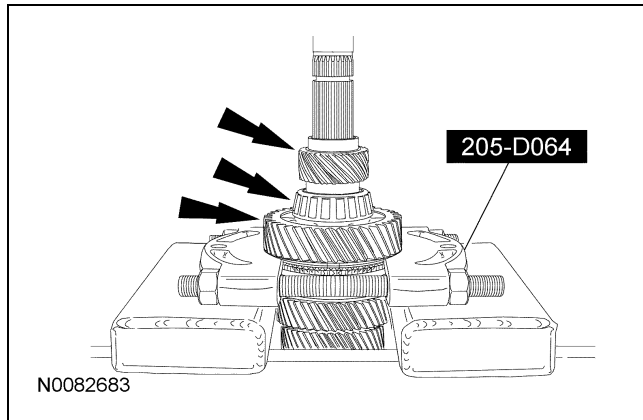

3. Remove the 1st gear needle bearing.
- Inspect the needle bearing for wear or damage. Install a new needle bearing as necessary.
4. Remove the 1st gear synchronizer inner cone, the outer cone and the blocking ring.
- Inspect all components for wear or damage. Install new components as necessary.

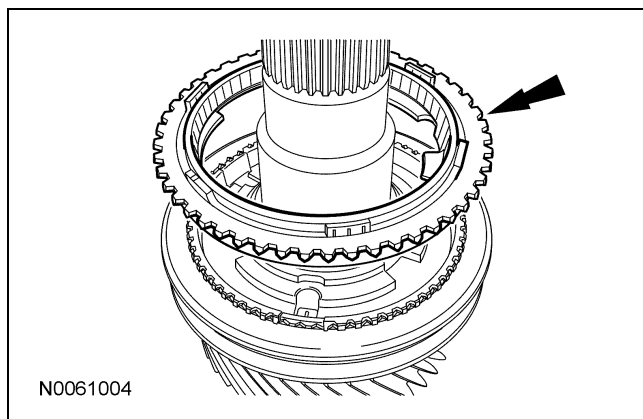

5. Remove the synchronizer sleeve and the 3 synchronizer keys.

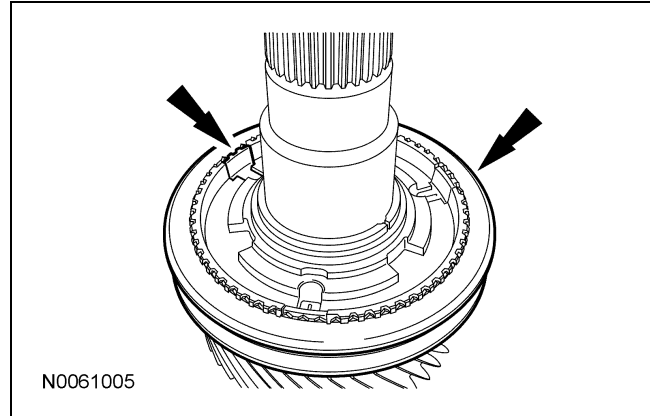

6. Remove the split washer.

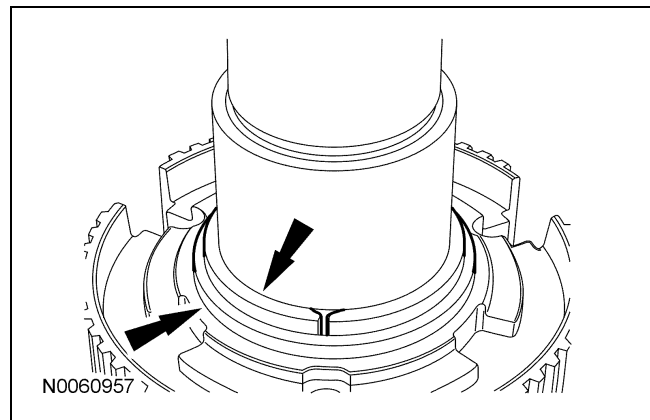

7. Remove the 1st/2nd gear synchronizer hub.
8. Remove the inner cone, the outer cone, the 2nd gear synchronizer blocking ring and the synchronizer hub.
- Inspect all synchronizer components for wear or damage. Install new components as necessary.

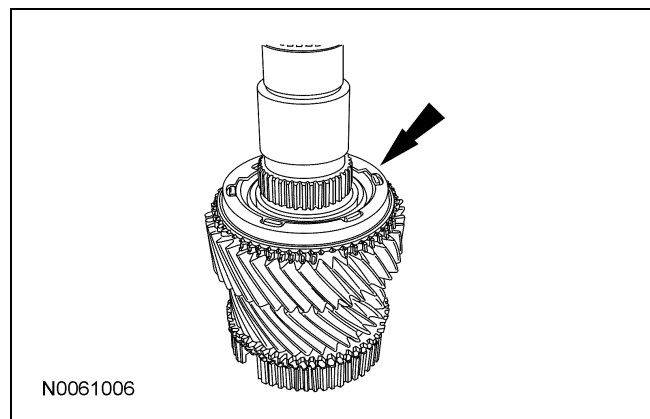

DISASSEMBLY AND ASSEMBLY (Continued)

9. Remove 2nd gear.

- Inspect 2nd gear for wear or damage. Install a new gear as necessary.

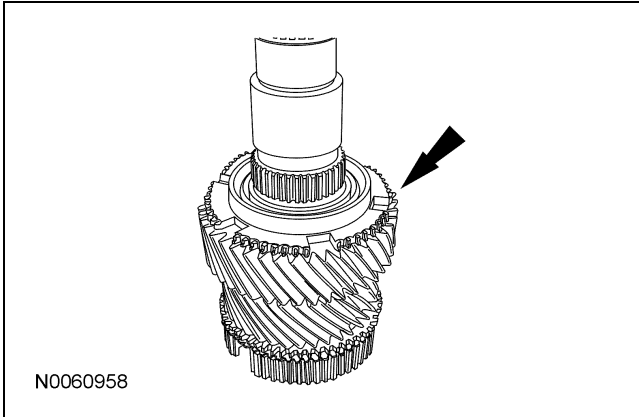

10. Remove the 2nd gear needle bearing and the spacer.

- Inspect the needle bearing for wear or damage. Install a new needle bearing as necessary.

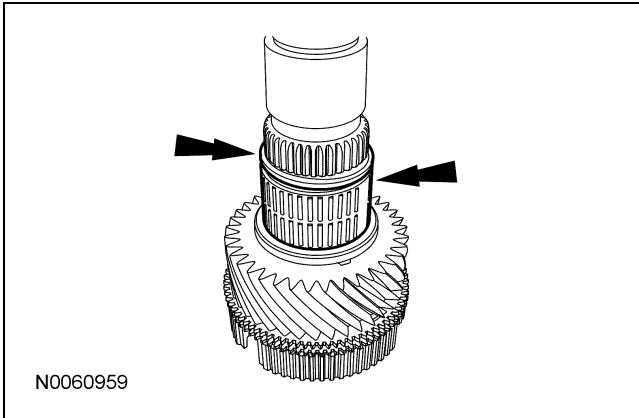
11. **NOTE:** Reposition the output shaft on the press with the input shaft end facing upward.

Remove and discard the snap ring, then using the Bearing Puller, remove the 3rd/4th gear synchronizer assembly, the 3rd gear synchronizer double cone and the 3rd gear.

- Inspect the gear for broken or cracked teeth. Install a new gear as necessary.
- Inspect all synchronizer components for wear or damage. Install new components as necessary.

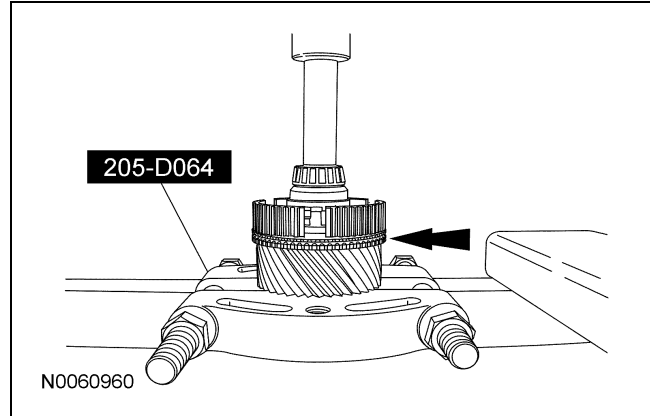

12. Remove the 3rd gear needle bearing and the spacer.

- Inspect the needle bearing for wear or damage. Install a new needle bearing as necessary.

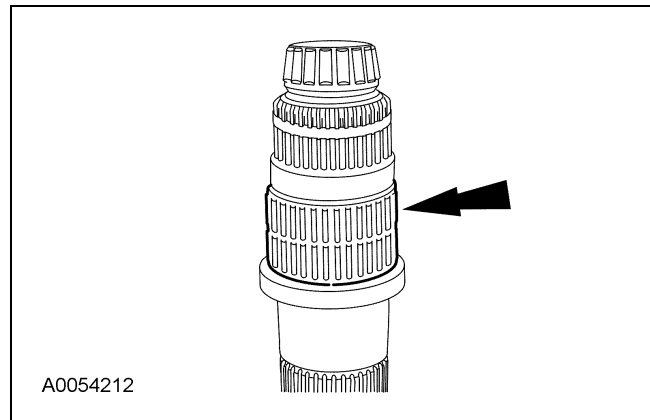
13. **NOTE:** Install the Bearing Puller with the flat side facing the bearing.

Using the Bearing Puller, press the output shaft front bearing from the output shaft. Discard the bearing.

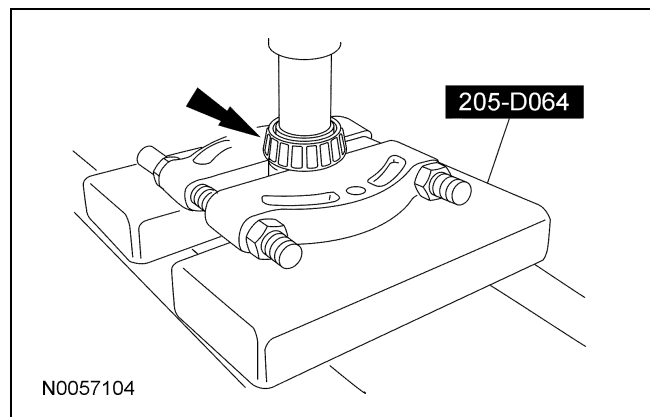

DISASSEMBLY AND ASSEMBLY (Continued)

14. Inspect the synchronizers.
- Check for worn, nicked or broken teeth. Install a new synchronizer as necessary.
 - Check keys for wear or damage. Install a new synchronizer as necessary.
15. Inspect the synchronizer blocking rings.
- Check for wear or damage. Install new synchronizer blocking rings as necessary.
 - Check the clearance between the synchronizer blocking ring and the gear.
 - Position the blocking ring onto the gear. Make sure the correct blocking ring is measured with the correct gear and that the blocking ring is fully seated on the gear.
 - Insert a feeler gauge and measure the clearance, while applying pressure and rotating the blocking ring. The measurement should be the same around the entire circumference. If the clearance is less than 0.38 mm (0.015 in), install new blocking rings.

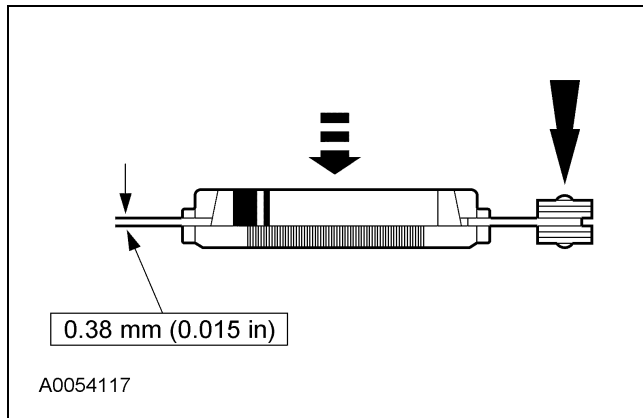

16. Inspect the output shaft for scoring or worn or damaged splines. Install a new output shaft as necessary.

Assembly

1. Lubricate all components with the recommended transmission fluid when reassembling.
2. Using the Bearing Puller and the Output Shaft Rear Bearing Installer with the Adapter, press the new output shaft front bearing on the output shaft.

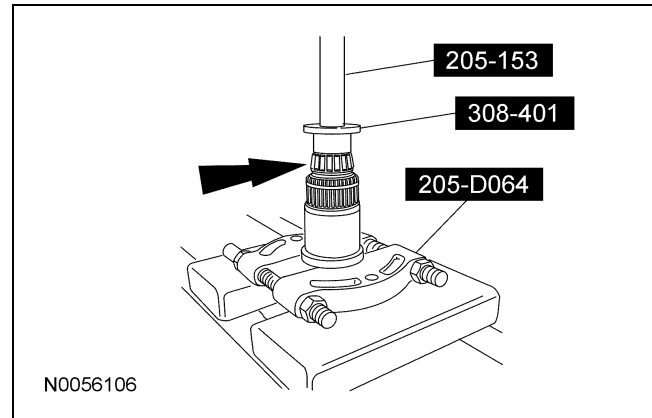

3. Install the 3rd gear bearing and the spacer.
 - Apply petroleum jelly to the bearing.

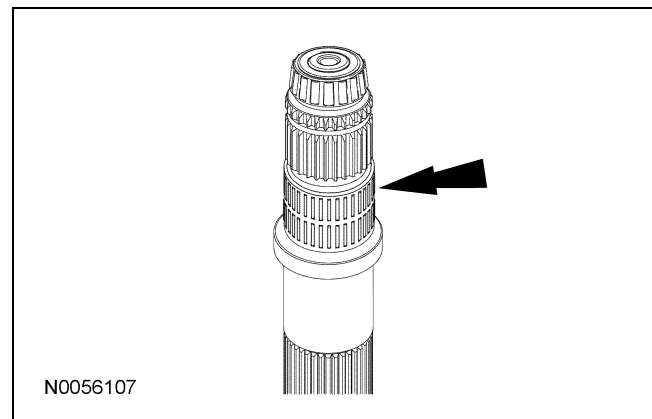

DISASSEMBLY AND ASSEMBLY (Continued)

4. Install 3rd gear, the 3rd gear synchronizer double cones and the 3rd/4th gear synchronizer assembly. Position the output shaft with the output end facing upward. Using the Bearing Puller, press the 3rd/4th gear synchronizer assembly into place.

- Install the synchronizer body with the groove facing 3rd gear.
- Stop press operation before keys engage the blocking ring slots. Lift and rotate the 3rd gear and the blocking ring until the keys are seated in the blocking ring.

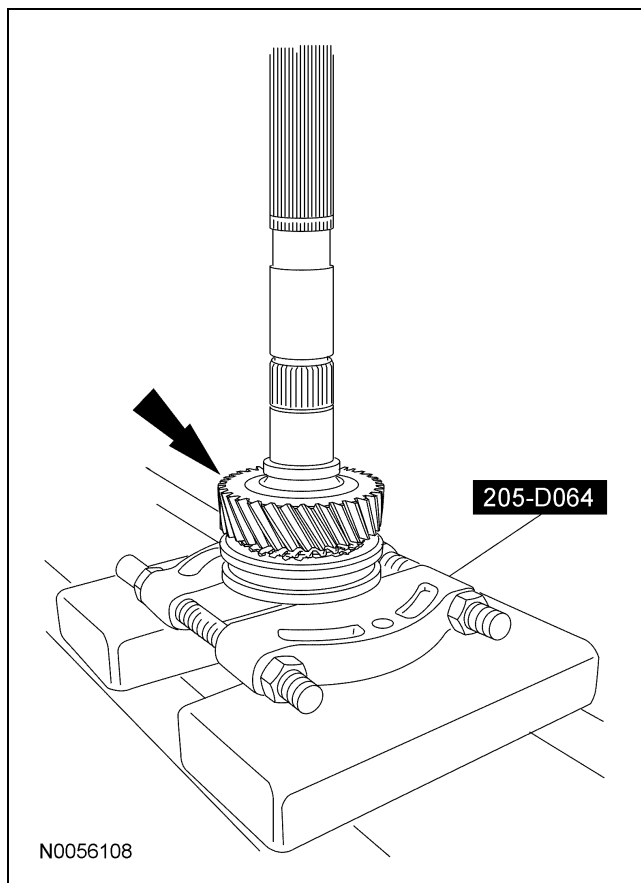

5. Install a new snap ring.
6. Install the 2nd gear needle bearing.
 - Apply petroleum jelly to the bearing.

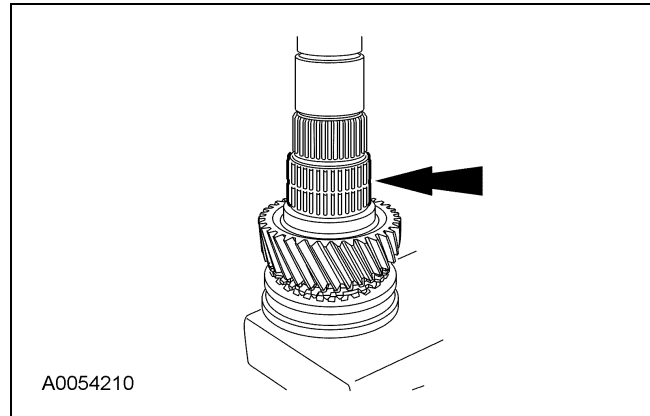

7. Install 2nd gear and the bearing spacer.

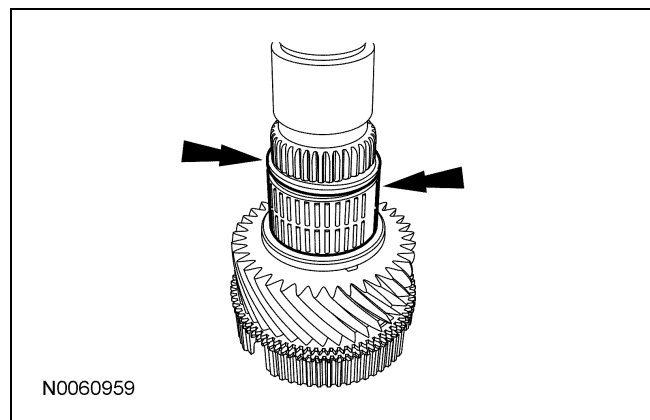

8. Install the 2nd gear, the inner cone, the intermediate cone and the 2nd gear synchronizer blocking ring.

- Align the blocking ring tabs with the 2nd gear slots.

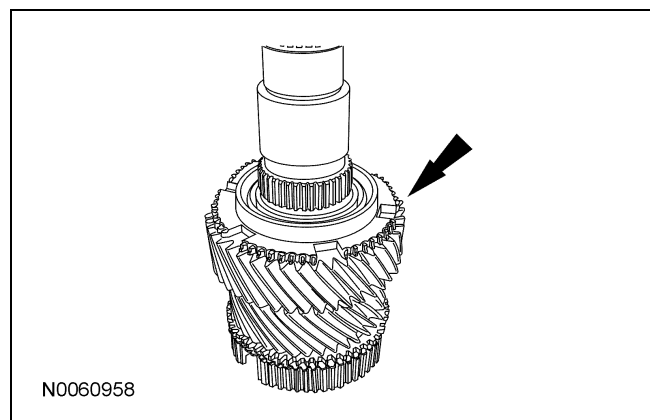

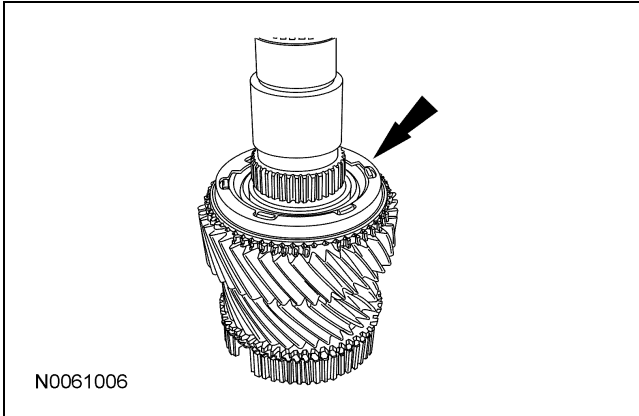
DISASSEMBLY AND ASSEMBLY (Continued)

9. Install the 1st/2nd gear synchronizer hub assembly into place.
 - Install the synchronizer with the groove on the sleeve facing 1st gear.
 - Lift and rotate the 2nd gear and the blocking ring until the keys are seated in the blocking ring.
10. Install the split washer.

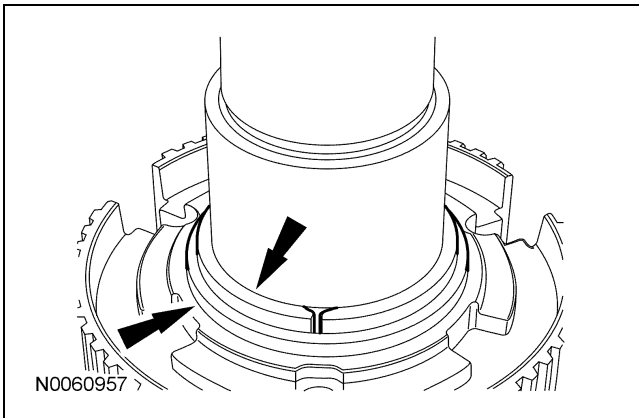

11. Install the 1st gear synchronizer sleeve and 3 synchronizer keys.

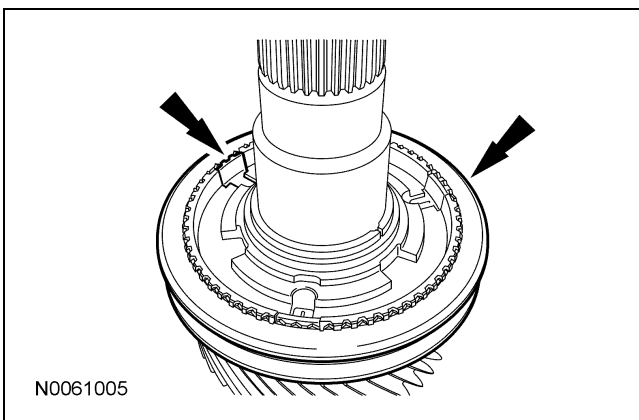

12. Install the 1st gear synchronizer inner cone, the intermediate cone and the 1st gear synchronizer blocking ring.

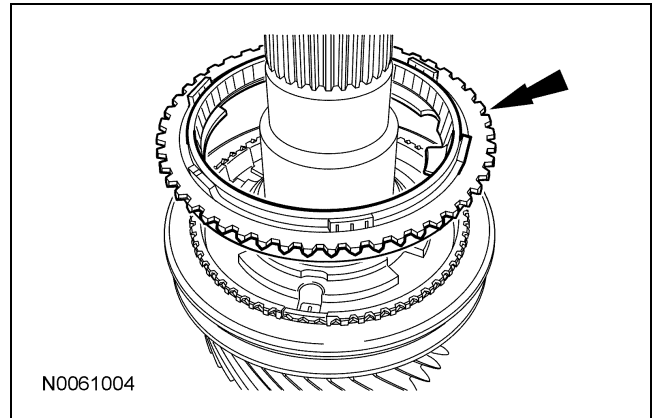

13. Install the 1st gear needle bearing.
 - Apply petroleum jelly to the bearing.

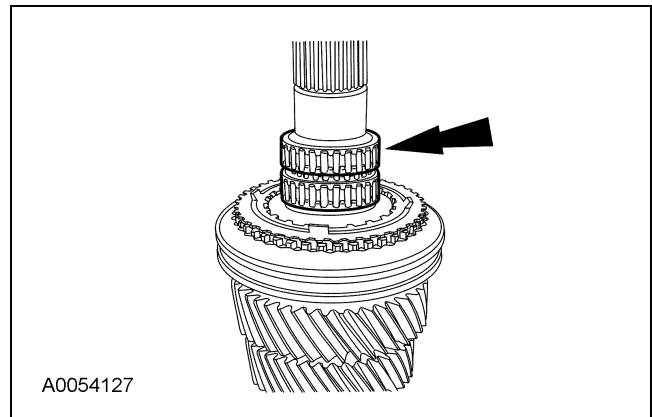

14. Install 1st gear.
 - Rotate the gear to align the gear slots with the intermediate cone tabs.
15. Using the Bearing Tube Remover/Installer, install a new rear output shaft bearing.

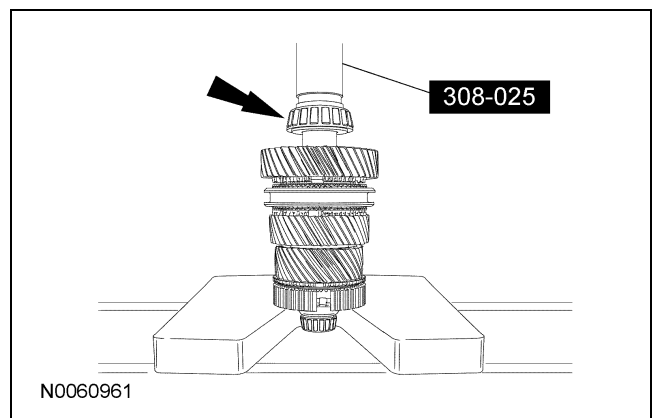

DISASSEMBLY AND ASSEMBLY (Continued)

- 16. Using the Bearing Tube Remover/Installer, install the 5th driven gear.

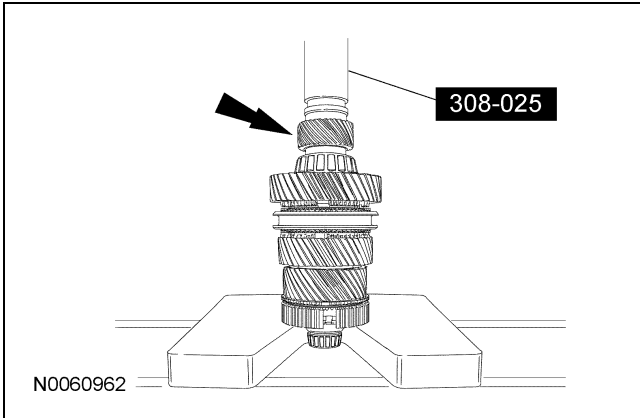

DISASSEMBLY AND ASSEMBLY

Countershaft

Special Tool(s)

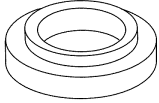
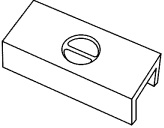
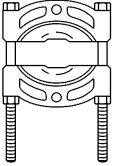
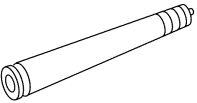
 <p>ST1308-A</p>	<p>Installer, Drive Pinion Bearing Cone 205-004 (T53T-4621-B)</p>
 <p>ST1254-A</p>	<p>Plate, Bearing Oil Seal 205-090 (T75L-1165-B)</p>
 <p>ST1368-A</p>	<p>Puller, Bearing 205-D064 (D84L-1123-A)</p>
 <p>ST1937-A</p>	<p>Remover/Installer, Bearing Tube 308-025 (T75L-7025-C)</p>

DISASSEMBLY AND ASSEMBLY (Continued)

Disassembly and Assembly

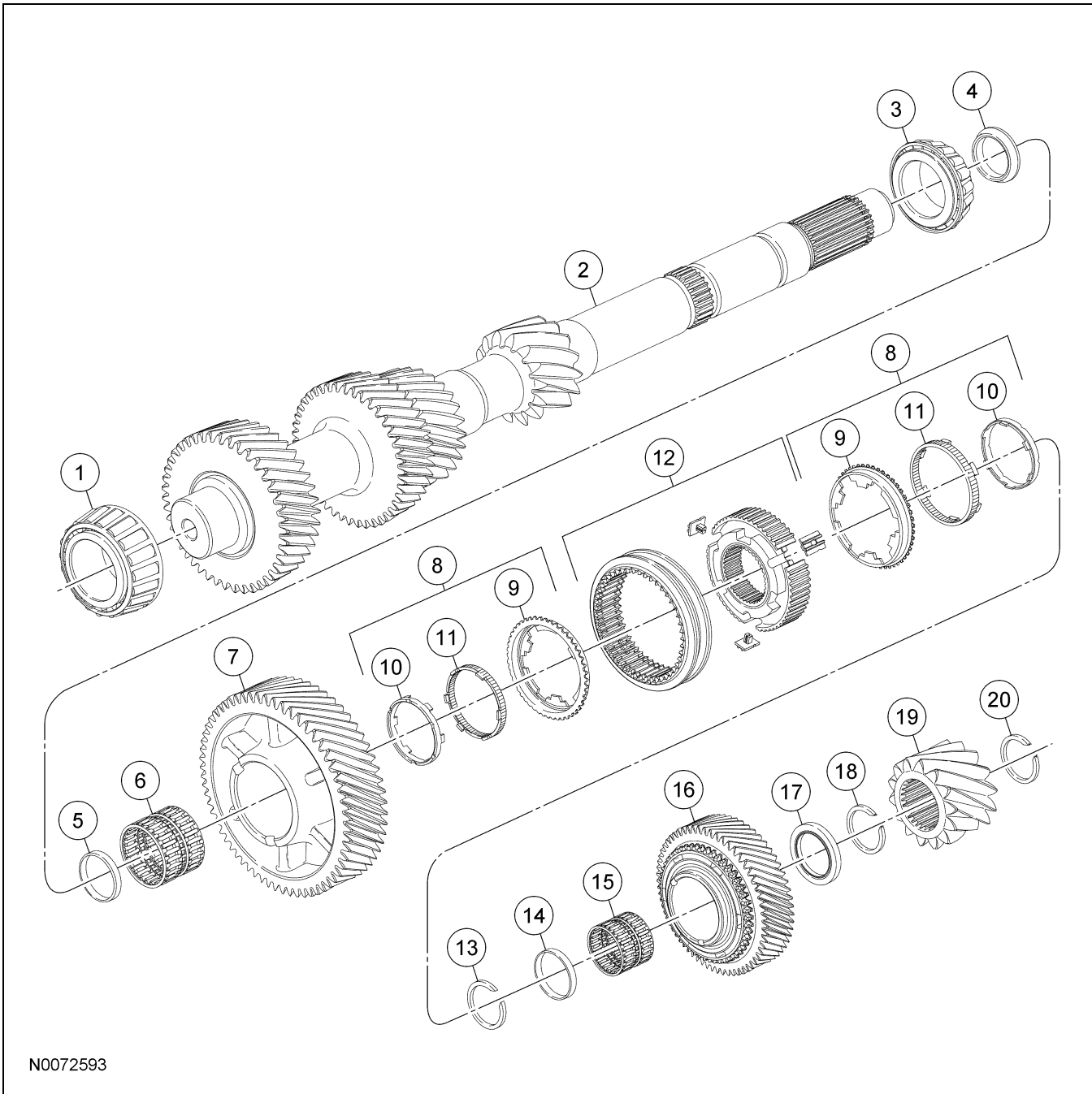

N0072593

Item	Part Number	Description
1	7025	Countershaft front bearing
2	7113	Countershaft
3	7025	Countershaft rear bearing
4	—	Thrust washer
5	7117	Spacer
6	7025	6th gear needle bearing
7	7146	6th gear

(Continued)

Item	Part Number	Description
8	7107	Synchronizer blocking ring assemblies
9	—	Synchronizer blocking rings (part of 7107)
10	—	Synchronizer inner cones (part of 7107)
11	—	Synchronizer outer cones (part of 7107)

(Continued)

DISASSEMBLY AND ASSEMBLY (Continued)

Item	Part Number	Description
12	7124	5th/6th synchronizer assembly
13	7A082	Snap ring
14	7117	Spacer
15	7025	5th gear needle bearing
16	7144	5th gear
17	7025	Thrust washer
18	7A082	Snap ring
19	—	Reverse driver gear
20	7A082	Snap ring

- Using the Bearing Puller and a press, remove the countershaft rear bearing.

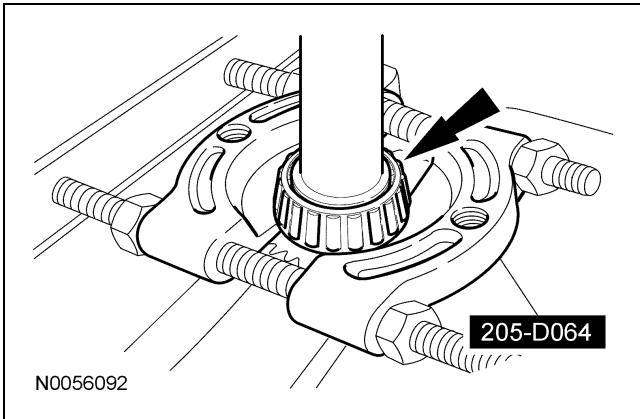

- Using the Bearing Puller and a press, remove the countershaft front bearing.

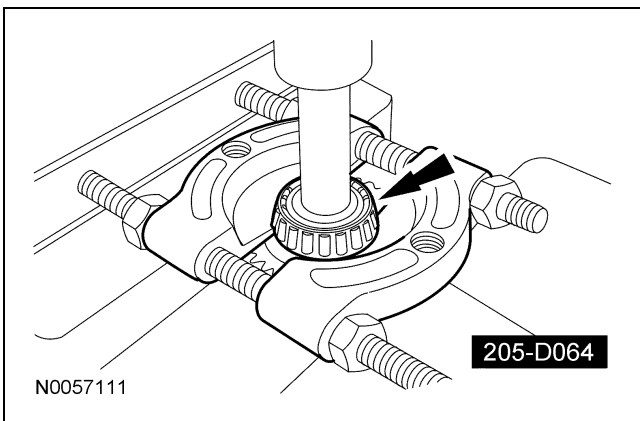

- Inspect the countershaft.
 - Check the shaft surface for wear or damage. Install a new shaft as necessary.
 - Check the gear teeth for wear, pitting, scoring, spalling or fractures. Install new components as necessary.
- Using the Bearing Oil Seal Plate and the Bearing Tube Remover/Installer, install the countershaft rear bearing.

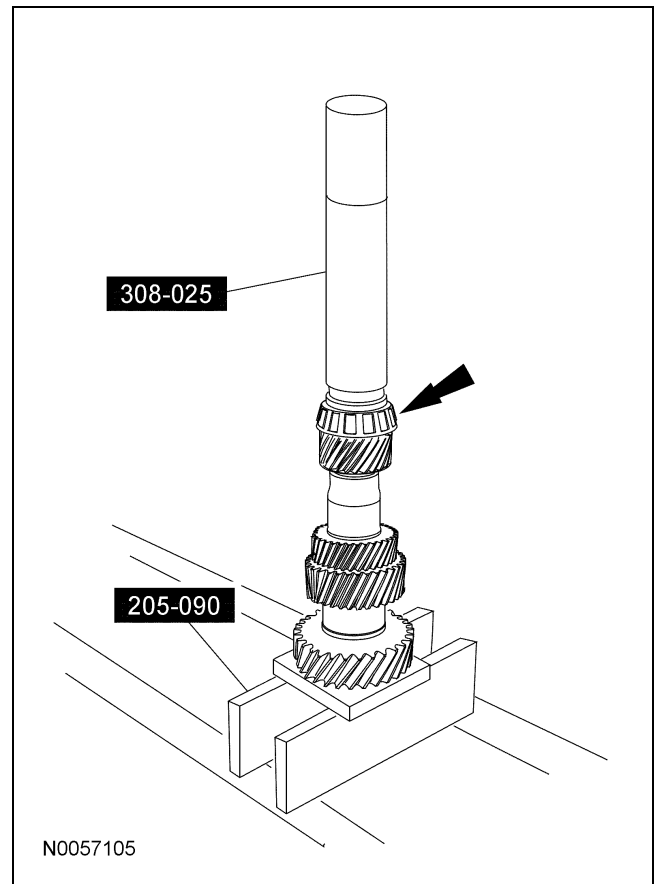

DISASSEMBLY AND ASSEMBLY (Continued)

5. Using the Drive Pinion Bearing Cone Installer and the Bearing Tube Remover/Installer, install the countershaft front bearing.

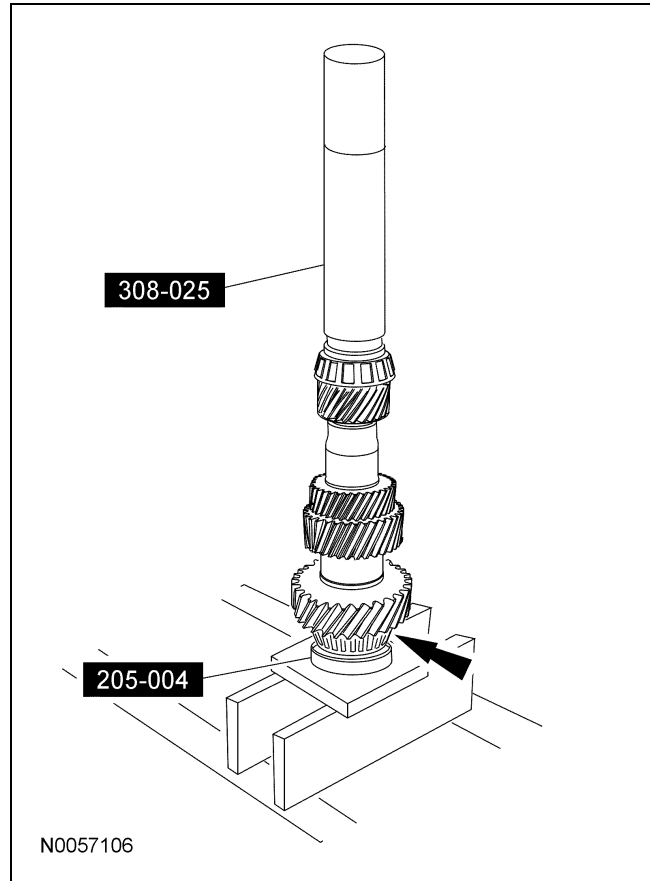

DISASSEMBLY AND ASSEMBLY

Gearshift Rail and Fork

Disassembly and Assembly

1st/2nd and 3rd/4th Shift Rail Assembly

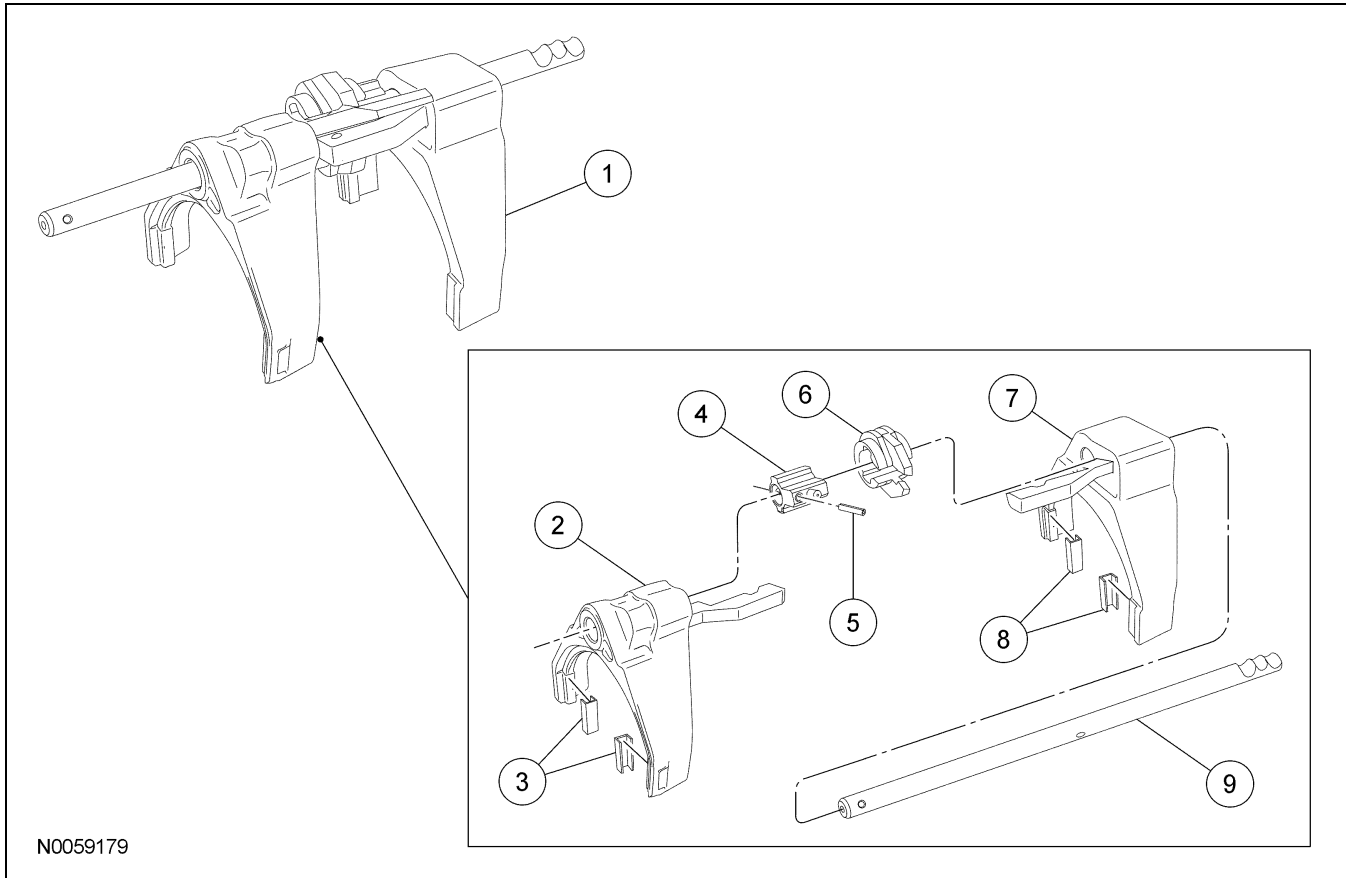

N0059179

Item	Part Number	Description
1	—	1st/2nd and 3rd/4th shift rail assembly
2	7230	1st/2nd shift fork and link
3	7L082	1st/2nd shift fork pads
4	7814	Selector pin
5	7A082	Roll pin

(Continued)

Item	Part Number	Description
6	7K201	Interlock plate
7	7230	3rd/4th shift fork and link
8	7L082	3rd/4th shift fork pads
9	7L267	1st/2nd, 3rd/4th shift rail

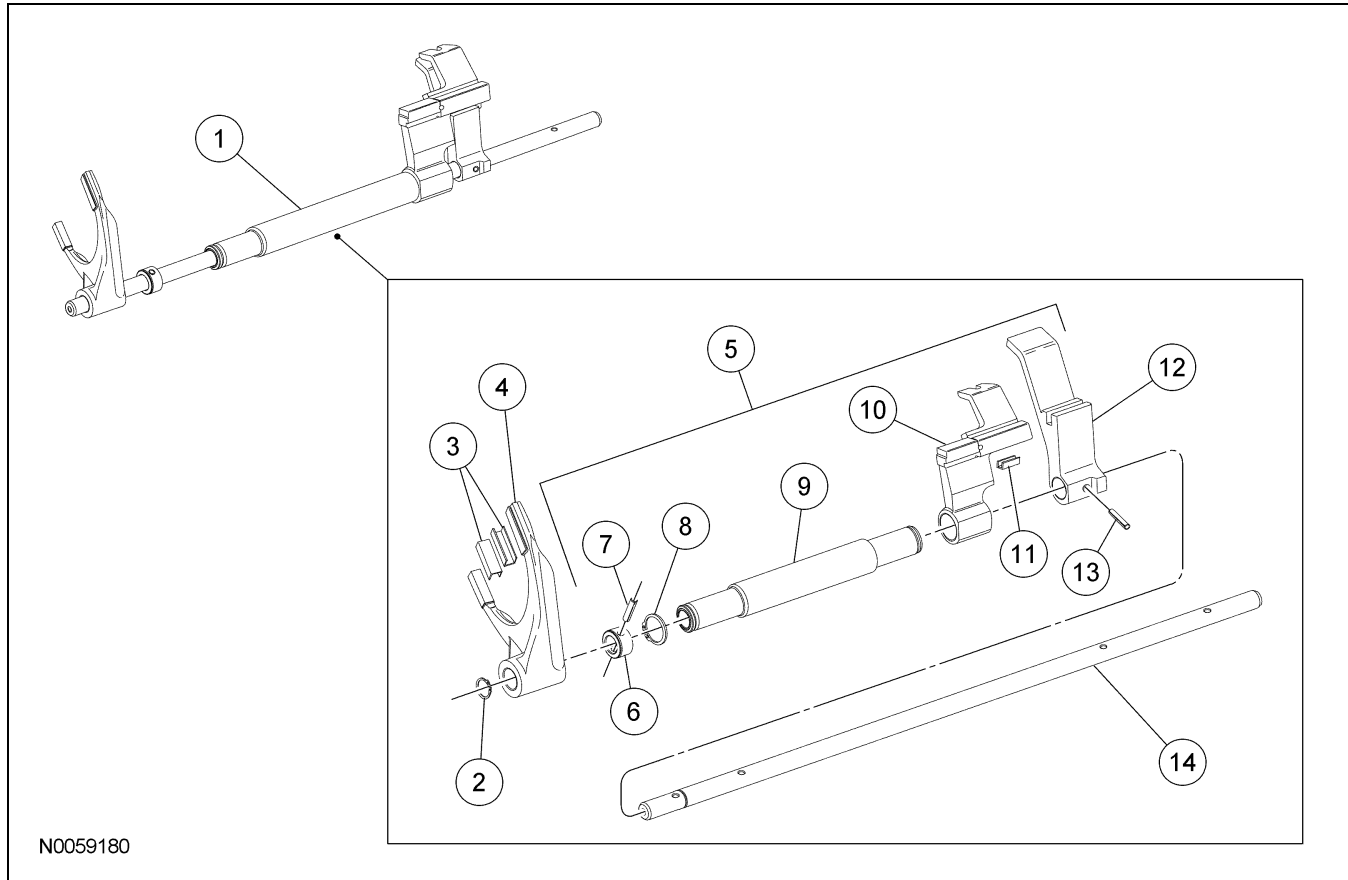
DISASSEMBLY AND ASSEMBLY (Continued)**5th/6th and Reverse Shift Rail Assembly**

Item	Part Number	Description
1	—	5th/6th and reverse shift rail assembly
2	7A082	Snap ring
3	7L082	Reverse shift fork pads
4	7230	Reverse shift fork
5	7241	5th/6th shift rail assembly
6	—	Shift rail collar (part of 7241)
7	—	Roll pin (part of 7241)
8	—	Snap ring (part of 7241)
9	—	5th/6th inner shift rail lever (part of 7241)
10	—	5th/6th outer shift rail lever (part of 7241)
11	—	5th/6th outer shift lever pad (part of 7241)
12	—	Reverse shift rail lever (part of 7241)
13	—	Roll pin (part of 7241)
14	—	5th/6th shift rail (part of 7241)

- Disassemble the 1st/2nd and 3rd/4th shift rail as follows:
 - Rotate the interlock plate until it is opposite of the shift links.
 - Slide off the 3rd/4th shift fork and shift link.
 - Slide off the 1st/2nd shift fork and shift link.
 - Using a 5/32-inch drift and a hammer, remove and discard the roll pin. Remove the interlock plate.
- Disassemble the 5th/6th and reverse shift rail as follows:
 - Using a 5/32-inch drift and a hammer, remove and discard the roll pins. Slide the collar and the reverse shift lever from the shift rail.
 - Remove and discard the snap ring.
 - Slide off the 5th/6th shift lever and shift link.
 - Using a press, separate the 5th/6th outer shift rail lever from the inner shift rail lever.

DISASSEMBLY AND ASSEMBLY (Continued)

3. Inspect the shift rail components.
 - Check the rails, shift forks, shift levers and shift links for wear or damage. Install new components as necessary.
 - Check the shift fork pads for wear. Install new pads as necessary.
4. To assemble, reverse the disassembly procedure.
 - Install new roll pins and snap ring.

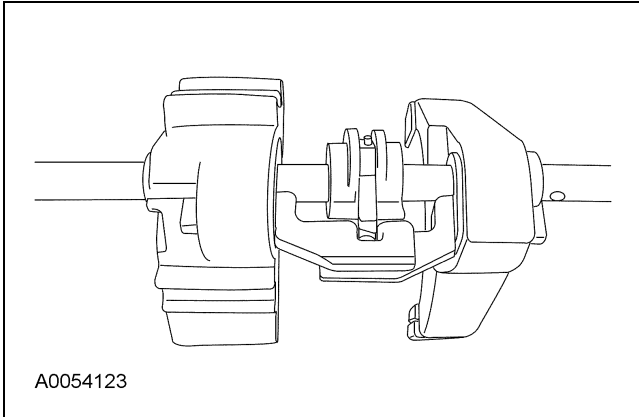
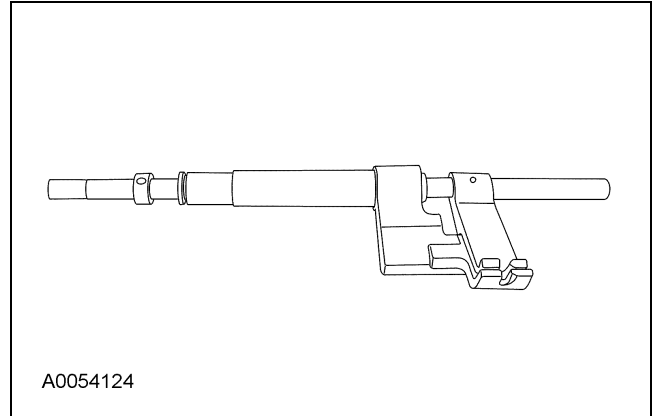

DISASSEMBLY AND ASSEMBLY

Extension Housing

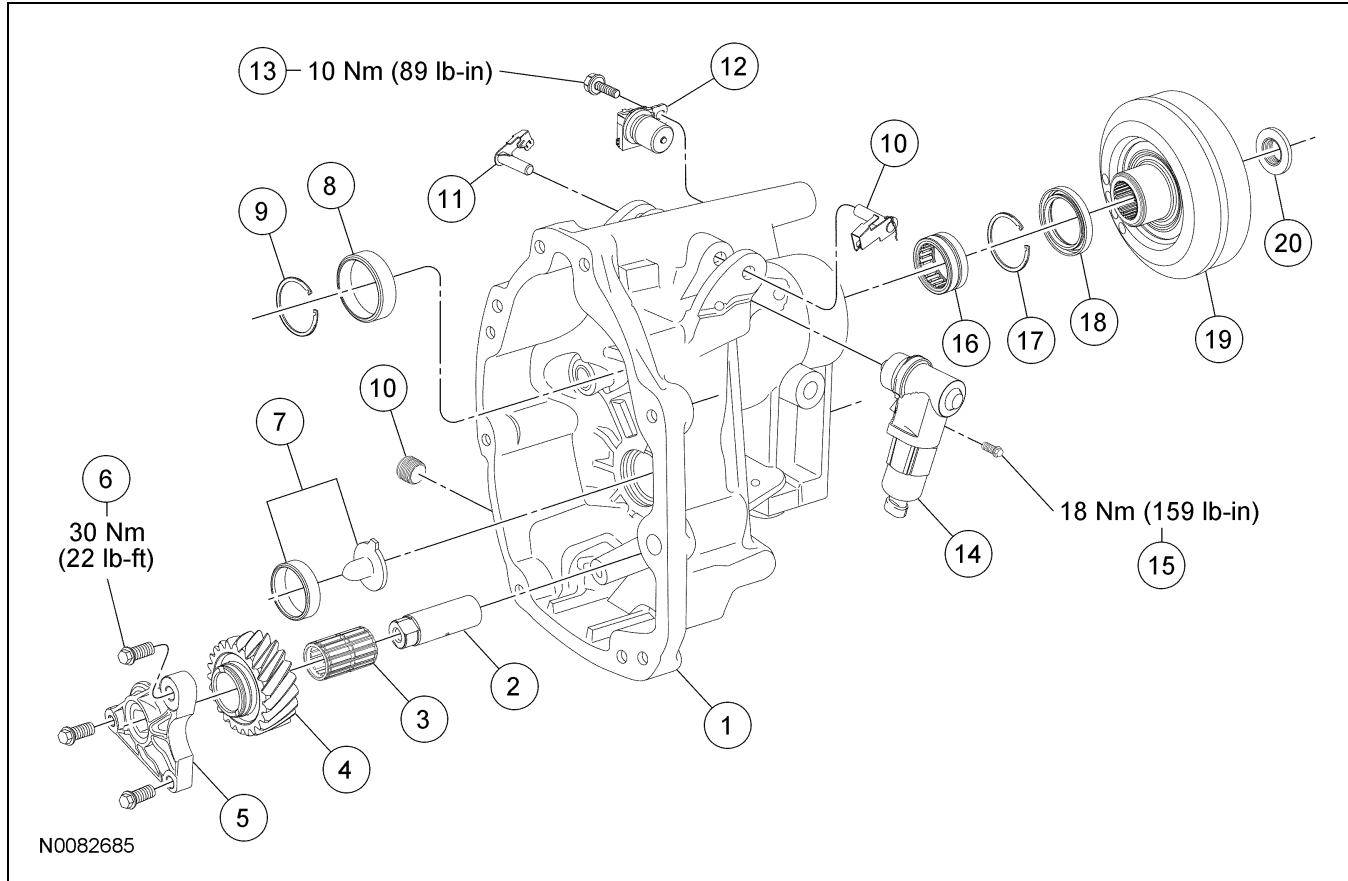

Item	Part Number	Description
1	7A039	Extension housing
2	7140	Reverse idler gear shaft
3	7025	Reverse idler gear needle bearing
4	7141	Reverse idler gear
5	7723	Reverse idler shaft bracket
6	—	Reverse idler shroud bracket bolt
7	—	Countershaft bearing cup and fluid funnel
8	—	Output shaft bearing cup
9	—	Snap ring
10	7A010	Case plugs

Item	Part Number	Description
11	7314	Shift linkage retainer
12	7H103	Output Shaft Speed (OSS) sensor
13	7A443	OSS sensor bolt
14	7374	Reverse lockout solenoid
15	—	Reverse lockout solenoid bolt
16	7025	Output shaft bearing
17	7A082	Output shaft bearing snap ring
18	7052	Extension housing seal
19	7089	Output flange
20	7K440	Output flange nut

(Continued)

DISASSEMBLY AND ASSEMBLY (Continued)

1. Remove the Output Shaft Speed (OSS) bolt and the OSS sensor.
 - To install, tighten to 10 Nm (89 lb-in).

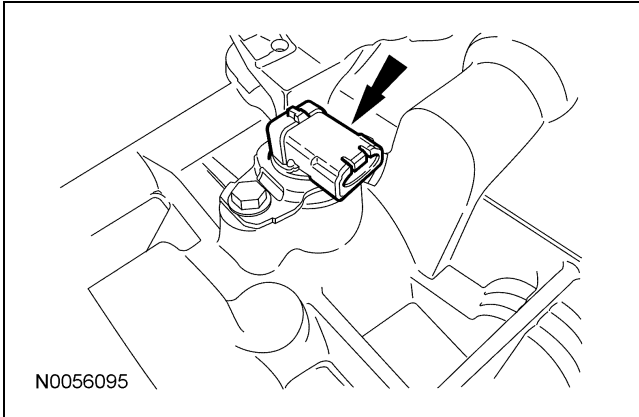

2. Remove the reverse lockout solenoid bolt and the reverse lockout solenoid.
 - To install, tighten to 18 Nm (159 lb-in).

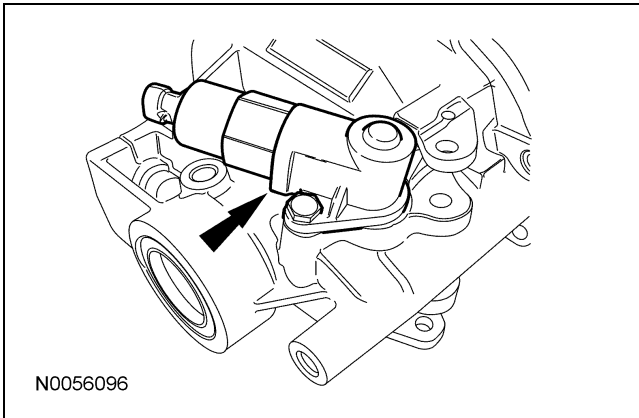

3. Remove the 3 reverse idler shaft bracket bolts and the reverse idler shaft bracket.
 - To install, tighten to 30 Nm (22 lb-ft).

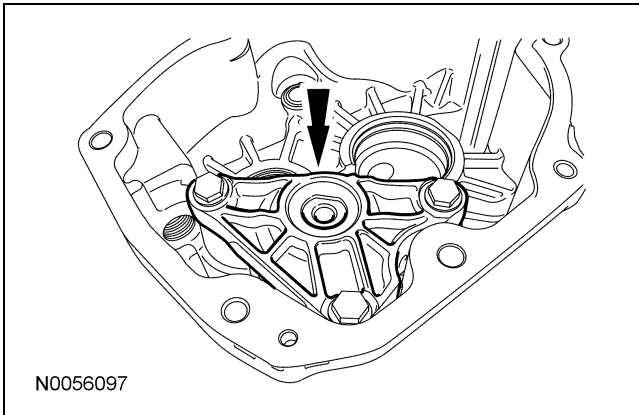

4. Remove the reverse idler gear.

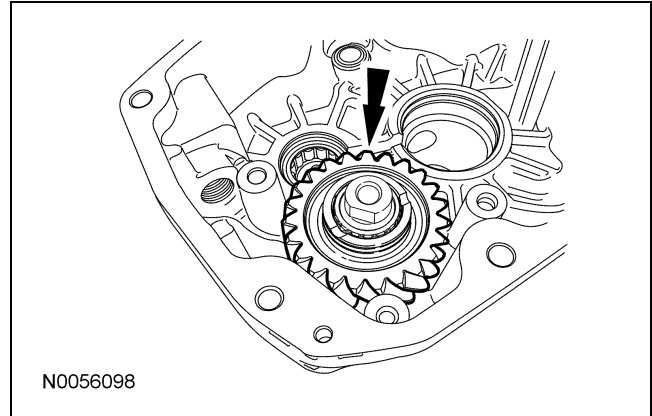

5. Remove the reverse idler gear needle bearing.
 - Inspect the needle bearing for wear or damage. Install a new bearing as necessary.

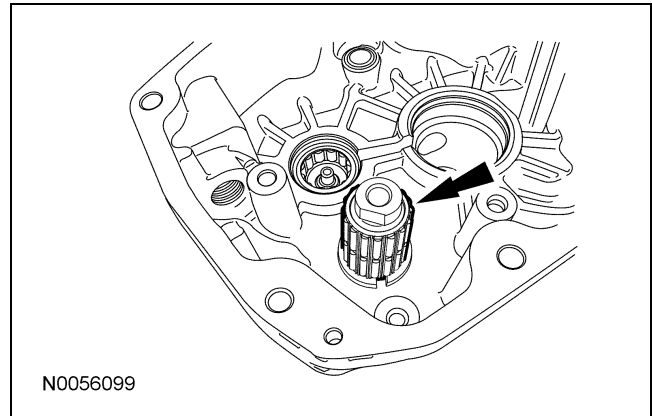

6. Remove the reverse idler gear shaft.

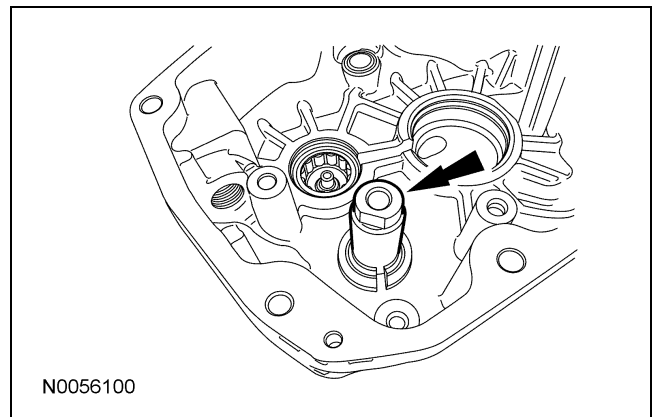

7. If necessary, remove the bearing and fluid funnel assembly.
8. Remove the countershaft bearing cup snap ring and the bearing cup.
 - Discard the snap ring.

DISASSEMBLY AND ASSEMBLY (Continued)

9. Remove and discard the extension housing seal.

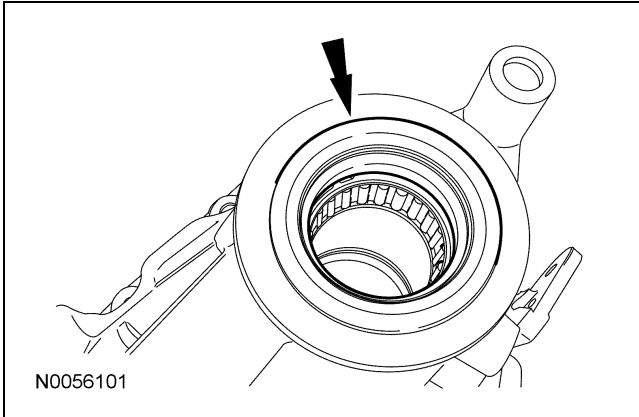

10. Clean the housing with solvent and dry with compressed air. Clean and check the sealing surface for nicks or scratches. Inspect the housing for cracks.

- If the housing is cracked, install a new housing. If the sealing surface has nicks or scratches, use a soft stone or crocus cloth to remove.

11. Remove and discard the snap ring. Position the extension housing with the seal facing downward. Using a brass drift, remove the output shaft bearing.

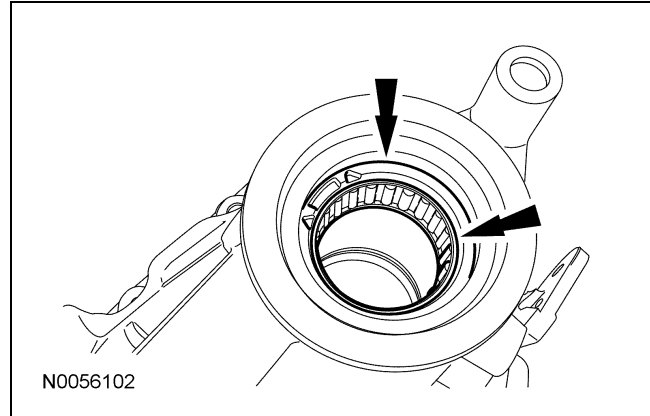

12. To assemble, reverse the disassembly procedure.

- Install new snap rings.

DISASSEMBLY AND ASSEMBLY

Transmission Case

Special Tool(s)

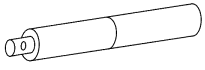
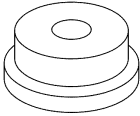
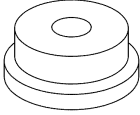
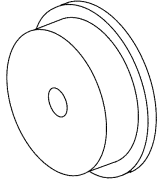
 <p>ST2336-A</p>	<p>Handle 205-D055 (D81L-4000-A)</p>
 <p>ST1555-A</p>	<p>Installer, Bearing Cup 204-039 (T77F-1217-B)</p>
 <p>ST1555-A</p>	<p>Installer, Bearing Cup 204-080 (T83P-1104-AH1)</p>
	<p>Installer, Rear Axle Oil Seal 205-155 (T80T-4000-Y)</p>

DISASSEMBLY AND ASSEMBLY (Continued)

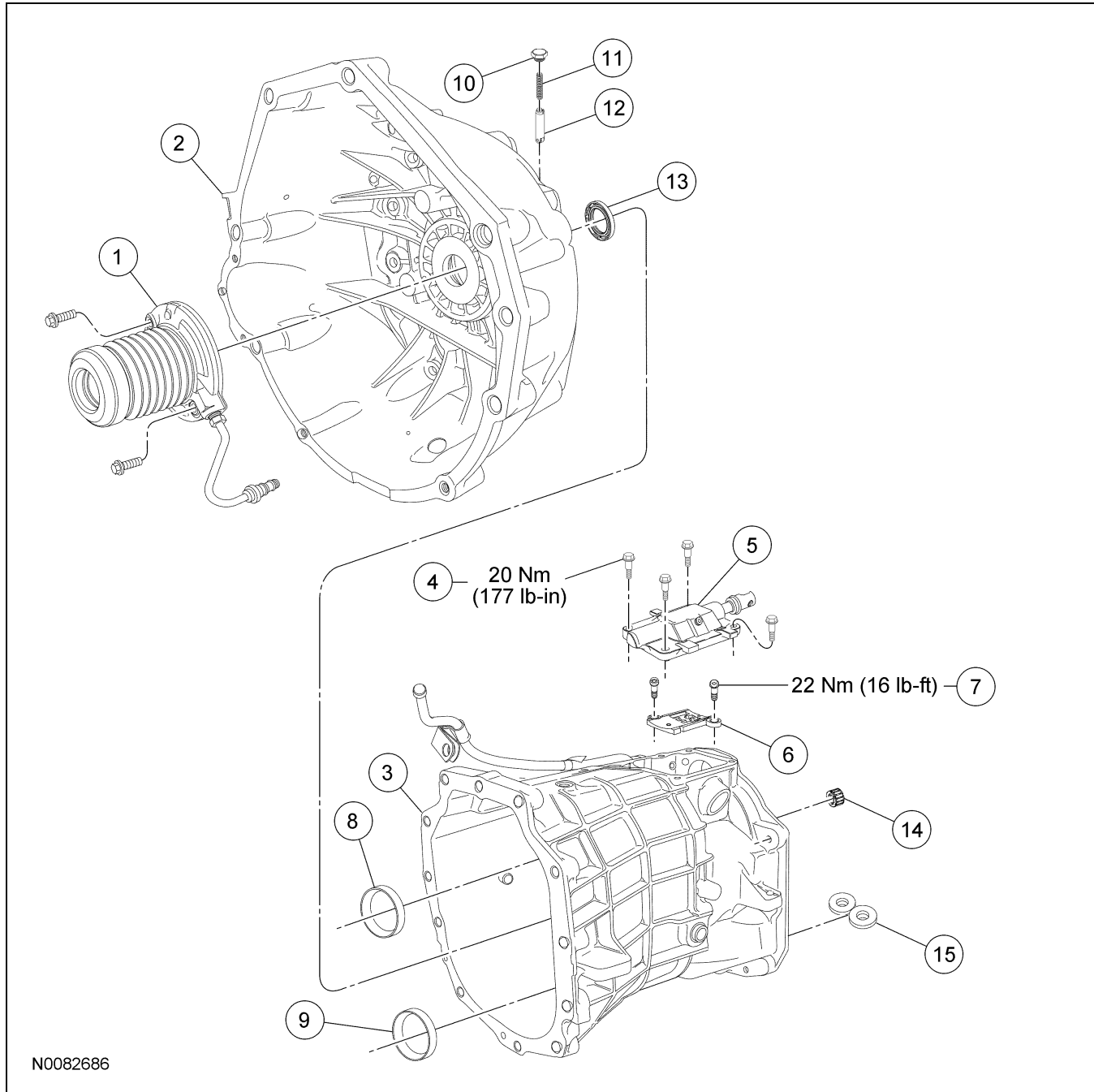

Item	Part Number	Description
1	7A508	Clutch slave cylinder
2	6392	Clutch housing
3	7005	Transmission main case
4	—	Shift cover bolt (4 required)
5	7C453	Shift cover assembly
6	7F476	Shift guide plate
7	—	Shift guide plate bolt (2 required)

Item	Part Number	Description
8	—	Output shaft bearing cup
9	—	Countershaft bearing cup
10	—	Shift detent plug
11	7234	Shift detent spring
12	—	Shift detent
13	7052	Input shaft seal
14	7127	Top shift rail bearing
15	7L027	Magnet

(Continued)

DISASSEMBLY AND ASSEMBLY (Continued)

Disassembly and Assembly

1. Remove the shift detent from the transmission main case.

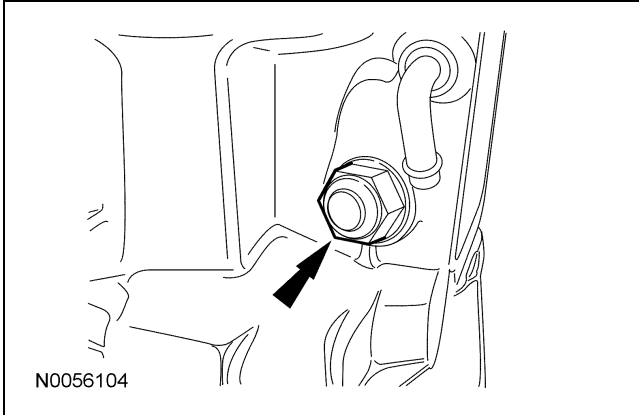

2. Remove the shift detent plug and the spring and shift detent from the clutch housing.
3. Remove the 2 guide plate bolts and the guide plate.
 - Inspect the plate for wear or damage. Install a new plate as necessary.
 - To install, tighten to 22 Nm (16 lb-ft).
4. **NOTE:** Do not remove the magnets. Clean the case magnets.

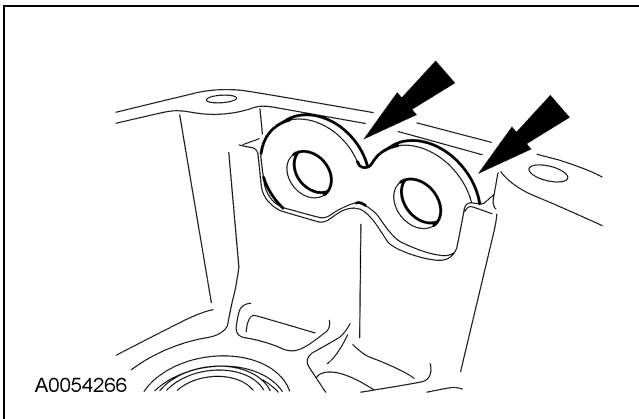

5. Remove the reverse lamp switch.
 - To install, tighten to 27 Nm (20 lb-ft).
6. Inspect the countershaft and mainshaft bearing cups for wear or damage. Install new components as necessary.

7. Using the Bearing Cup Installer with Handle, remove the countershaft bearing cup.

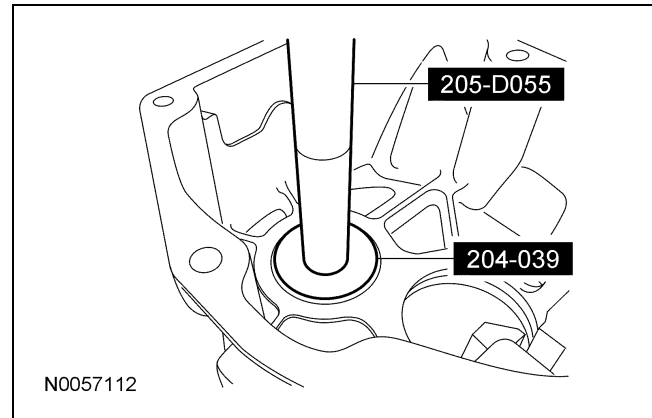

8. Using a suitable tool, remove mainshaft bearing cup.
9. Clean the case with solvent and dry with compressed air. Clean and check the sealing surface for nicks or scratches. Inspect the case for cracks.
 - If the case is cracked, install a new case. If the sealing surface has nicks or scratches, use a soft stone or crocus cloth to remove.
10. **NOTE:** If a new countershaft bearing is being installed, install a new bearing cup. Always install new bearings and cups in a set. Using the Bearing Cup Installer with Handle, install the countershaft bearing cup.

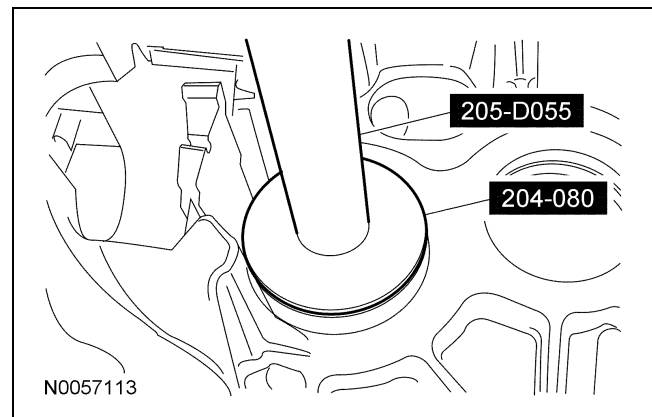

DISASSEMBLY AND ASSEMBLY (Continued)

11. **NOTE:** If a new mainshaft bearing is being installed, install a new bearing cup. Always install new bearings and cups in a set.

Using the Rear Axle Oil Seal Installer with Handle, install the mainshaft bearing cup.

12. To assemble, reverse the disassembly procedure.

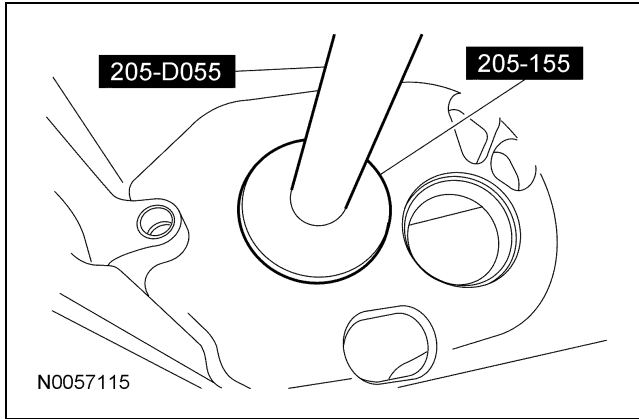

DISASSEMBLY AND ASSEMBLY

Transmission

Special Tool(s)

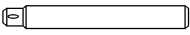
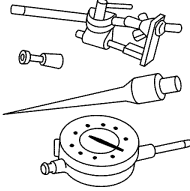
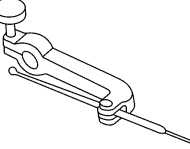
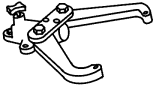
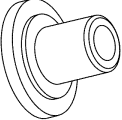
 ST1255-A	Adapter for 303-224 (Handle) 205-153 (T80T-4000-W)
 ST1214-A	Dial Indicator Gauge with Holding Fixture 100-002 (TOOL-4201-C) or equivalent
 ST1348-A	Gauge, Clutch Housing 308-021 (T75L-4201-A)
 ST1186-A	Holding Fixture, Transmission 307-003 (T57L-500-B)
 ST2355-A	Installer, Input Shaft Oil Seal 308-220 (T94P-7025-AH)

Material

Item	Specification
Silicone Gasket and Sealant TA-30	WSE-M4G323-A4
Threadlock and Sealer TA-25	WSK-M2G351-A5

Material

Item	Specification
MERCON® V Automatic Transmission Fluid XT-5-QM (or XT-5-QMC) (US); CXT-5-LM12 (Canada)	MERCON® V
Premium Long-Life Grease XG-1-C or XG-1-K (US); CXG-1-C (Canada)	ESA-M1C75-B

(Continued)

DISASSEMBLY AND ASSEMBLY (Continued)

Transmission Case and Shift Components — Disassembled View

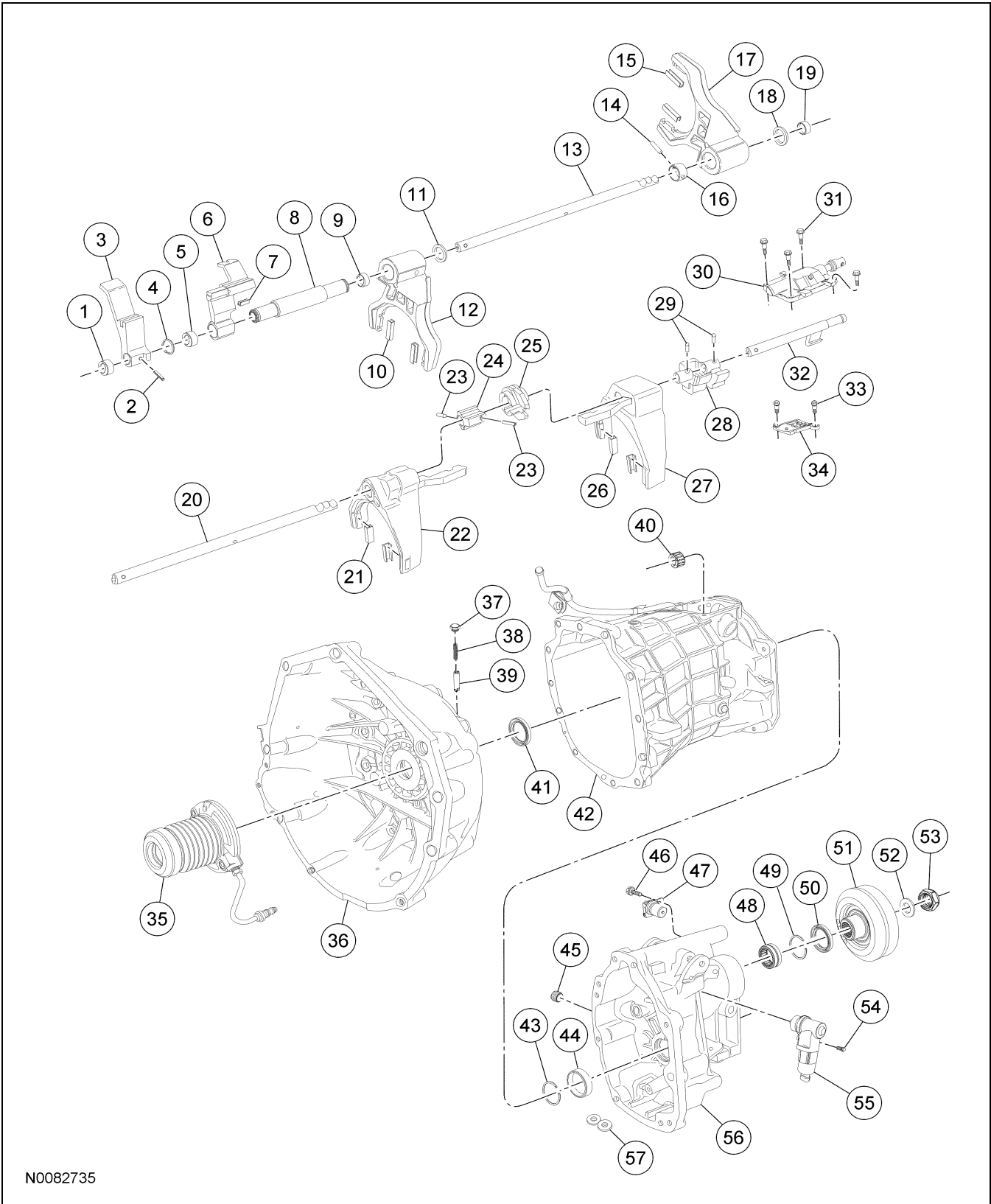

N0082735

DISASSEMBLY AND ASSEMBLY (Continued)

Item	Part Number	Description
1	7W425	Shift rail bushing
2	7A082	Roll pin
3	7241	Reverse shift rail lever
4	7A082	Snap ring
5	7W425	Shift rail bushing
6	7241	5th/6th outer shift rail lever
7	7241	5th/6th outer shift lever pad
8	7241	5th/6th inner shift rail lever
9	7W425	Shift rail bushing
10	7L082	3rd/4th shift fork pad
11	7241	Washer
12	7230B	3rd/4th shift fork
13	7241	5th/6th shift rail
14	7A082	Roll pin
15	7L082	Reverse shift fork pad
16	7241	Shift rail collar
17	7230	Reverse shift fork
18	7241	Washer
19	7W425	Shift rail bushing
20	7L267	1st/2nd, 3rd/4th shift rail
21	7L082	5th shift fork pad
22	7230	5th shift fork
23	7A082	Roll pins
24	7814	Selector pin
25	7K201	Interlock plate
26	7L082	1st/2nd shift fork pad
27	7230	1st/2nd shift fork
28	—	Shift gate
29	7A082	Roll pins
30	7C453	Shift cover assembly

(Continued)

Item	Part Number	Description
31	—	Shift cover bolt (4 required)
32	—	Shift guide rail
33	—	Shift guide plate bolt (2 required)
34	7F476	Shift guide plate
35	7A508	Clutch slave cylinder
36	6392	Clutch housing
37	7234	Shift detent plug
38	7234	Shift detent spring
39	7234	Shift detent
40	7127	Top shift rail bearing
41	7052	Input shaft seal
42	7005	Transmission main case
43	7A082	Snap ring
44	7025	Output shaft bearing cup
45	7A010	Case plug
46	7A443	Output Shaft Speed (OSS) sensor bolt
47	7H103	OSS sensor
48	7025	Output shaft bearing
49	7A082	Output shaft bearing snap ring
50	7052	Extension housing seal
51	7089	Output flange
52	7119	Thrust washer
53	7K440	Output flange nut
54	—	Reverse lockout solenoid bolt
55	7374	Reverse lockout solenoid
56	7A039	Extension housing
57	7L027	Magnet

DISASSEMBLY AND ASSEMBLY (Continued)

Transmission Gear Assemblies — Disassembled View

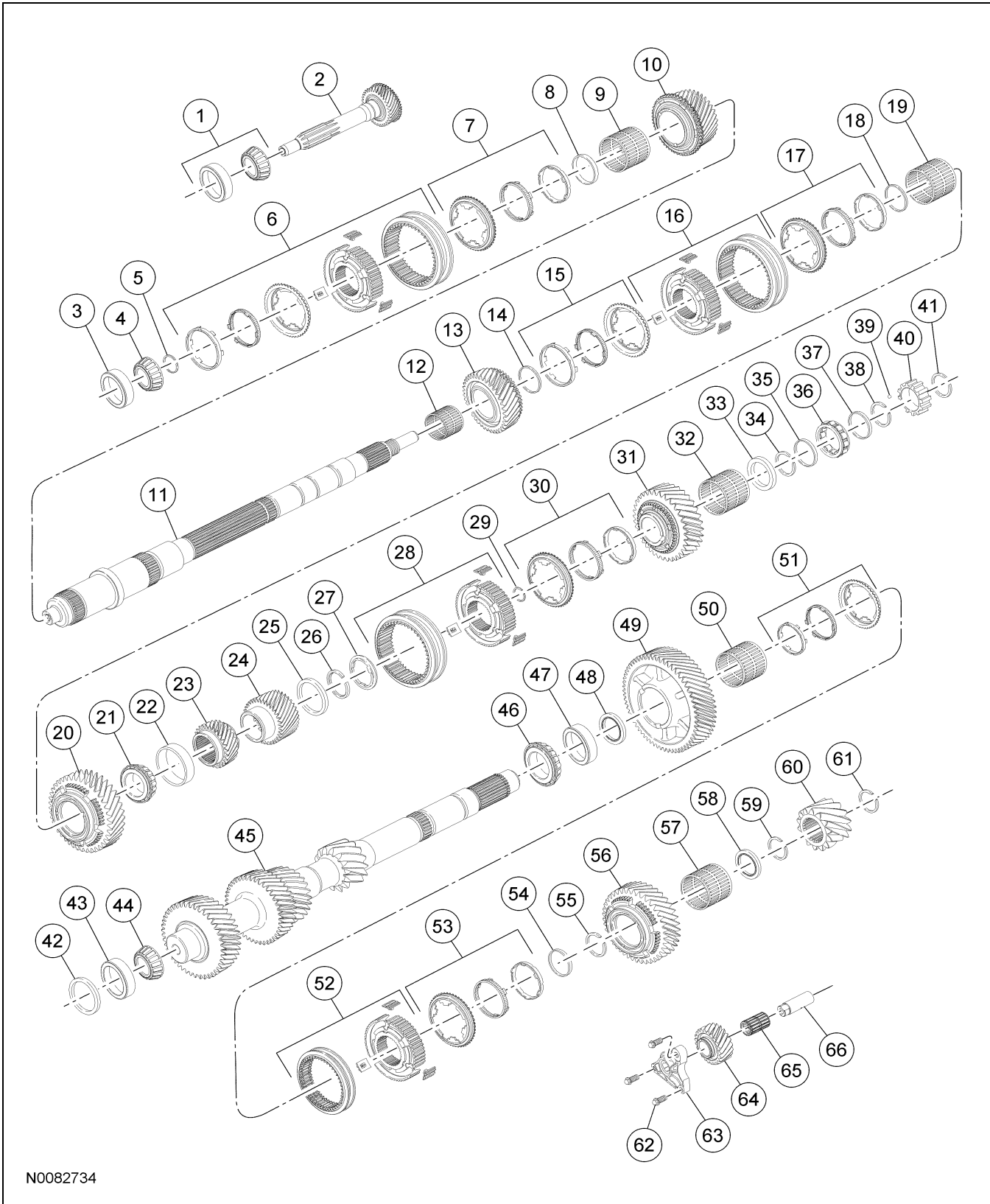

N0082734

DISASSEMBLY AND ASSEMBLY (Continued)

Item	Part Number	Description
1	7025	Input shaft bearing
2	7017	Input shaft
3	—	Output shaft bearing race
4	7025	Output shaft front bearing
5	7A082	Snap ring
6	7124	3rd/4th synchronizer assembly
7	7107	3rd/4th synchronizer blocking ring assembly
8	7117	Spacer
9	7025	3rd gear needle bearing
10	7B340	3rd gear
11	7061	Output shaft
12	7025	2nd gear needle bearing
13	7102	2nd gear
14	7117	Spacer
15	7107	2nd gear synchronizer blocking ring assembly
16	7124	1st/2nd synchronizer assembly
17	7117	1st gear synchronizer blocking ring assembly
18	7050	Spacer
19	7025	1st gear needle bearing
20	7100	1st gear
21	7025	Output shaft rear bearing
22	7025	Output shaft bearing race
23	7L047	6th driven gear
24	7K316	5th driven gear
25	7A082	Thrust washer
26	7A082	Split washer
27	—	Synchronizer cone (part of 7107)
28	7124	Reverse synchronizer assembly
29	7A082	Snap ring
30	7107	Reverse gear synchronizer blocking ring assembly
31	7C238	Reverse gear
32	7N168	Reverse gear needle bearing
33	7A385	Thrust washer
34	7A082	Snap ring

(Continued)

Item	Part Number	Description
35	7A082	Spacer
36	7025	Rear output shaft bearing
37	7A082	Spacer
38	7A082	Snap ring
39	7E172	Check ball
40	7H150	Speedometer rotor
41	7A082	Snap ring
42	7L172	Shim
43	7025	Countershaft front bearing race
44	7025	Countershaft front bearing
45	7113	Countershaft
46	7025	Countershaft rear bearing
47	7025	Countershaft rear bearing race
48	7025	Thrust washer
49	7146	6th gear
50	7025	6th gear needle bearing
51	7107	Synchronizer blocking ring assembly
52	7124	5th/6th synchronizer assembly
53	7107	Synchronizer blocking ring assembly
54	7117	Spacer
55	7A082	Snap ring
56	7144	5th gear
57	7025	5th gear needle bearing
58	7025	Thrust washer
59	7A082	Snap ring
60	—	Reverse driver gear
61	7A082	Snap ring
62	7C211	Reverse idler shroud bracket bolt
63	7723	Reverse idler shaft bracket
64	7141	Reverse idler gear
65	7025	Reverse idler gear needle bearing
66	7140	Reverse idler gear shaft

1. Lubricate all components with transmission fluid during assembly.

DISASSEMBLY AND ASSEMBLY (Continued)

2. Attach the transmission clutch housing to the Transmission Holding Fixture.

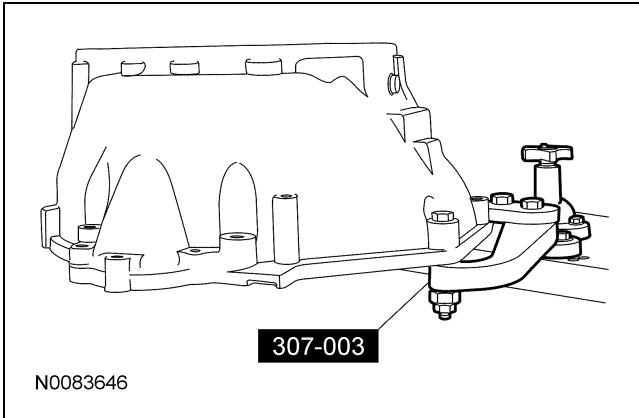

3. **NOTE:** If a new front input shaft bearing or front countershaft bearing was installed, install the new bearing cups.

Install the input shaft bearing cup and the countershaft bearing cup. Do not install the shims at this time.

4. Install the input shaft.
5. Install the output shaft onto the input shaft.
6. Install the countershaft.
 - Lift the output shaft upward, tilt the countershaft and install.

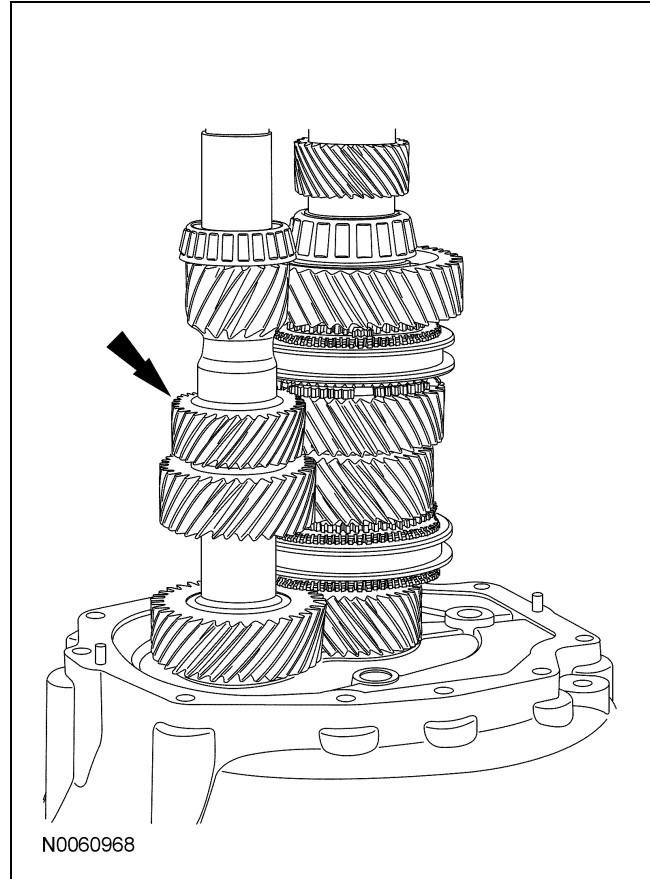

7. Install the transmission main case-to-clutch housing bolts.
 - Tighten to 48 Nm (35 lb-ft).

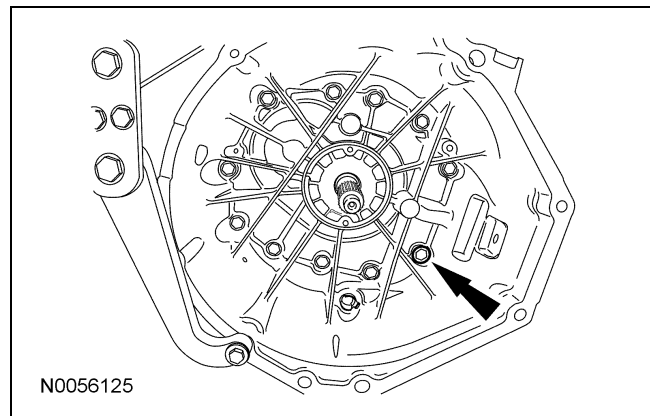

DISASSEMBLY AND ASSEMBLY (Continued)

8. **NOTE:** Rotate the input shaft/output shaft to seat the bearings.

Using the Dial Indicator Gauge with Holding Fixture and the Clutch Housing Gauge, measure the input shaft/output shaft end play by applying an upward load on the input shaft. Record the measurement.

- Input/output shaft preload specification is 0.0127-0.0889 mm (0.0005-0.0035 in).

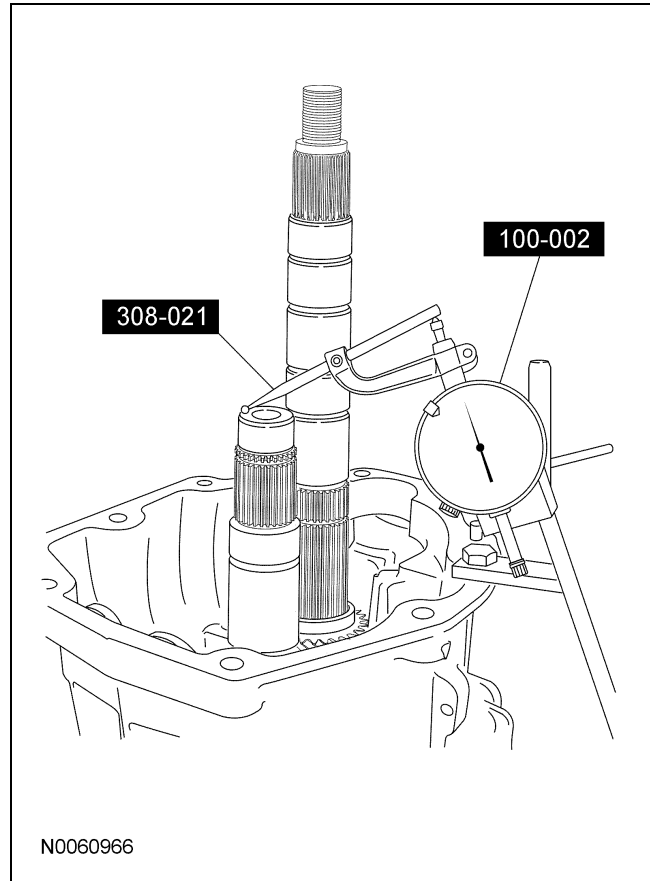
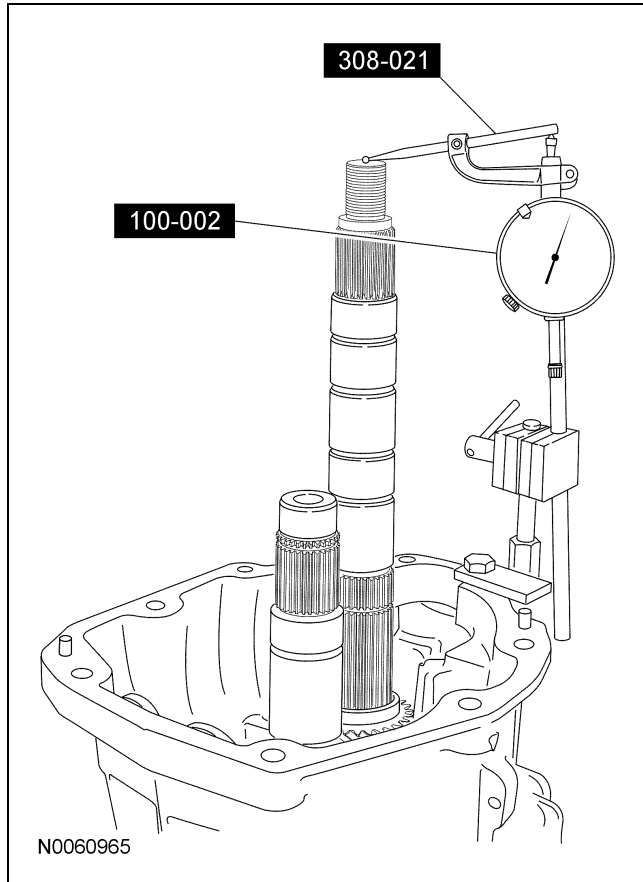

9. Reposition the Dial Indicator Gauge with Holding Fixture and the Clutch Housing Gauge on the countershaft.

10. **NOTE:** Rotate the countershaft to seat the bearings.

Using the Dial Indicator Gauge with Holding Fixture and the Clutch Housing Gauge, measure the countershaft gear end play by pulling upward on the countershaft. Record the measurement.

- Countershaft preload specification is 0.0127-0.0889 mm (0.0005-0.0035 in).

11. Remove the transmission case.
12. Remove the countershaft.
13. Remove the output shaft.
14. Remove the input shaft.
15. Remove the input shaft bearing cup and the countershaft bearing cup.

DISASSEMBLY AND ASSEMBLY (Continued)

16. Using the recorded end play measurements, select and install the appropriate shims to achieve the correct end play. Install the front input shaft bearing cup and the front countershaft bearing cup.

- Lubricate the bearing cups with petroleum jelly.

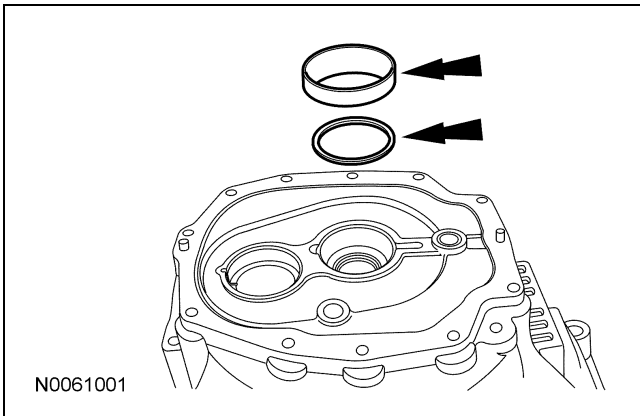
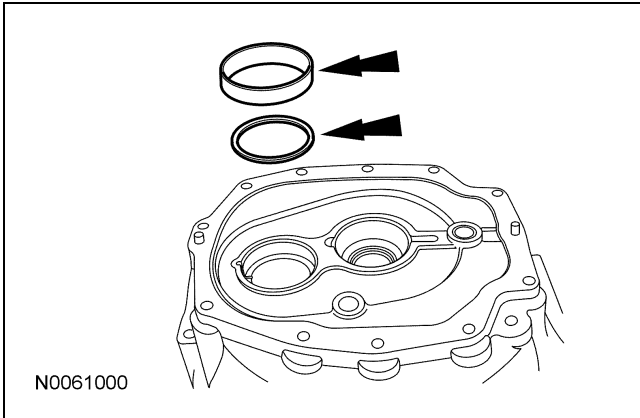

17. Using the Input Shaft Oil Seal Installer with Handle, install the new input shaft seal.

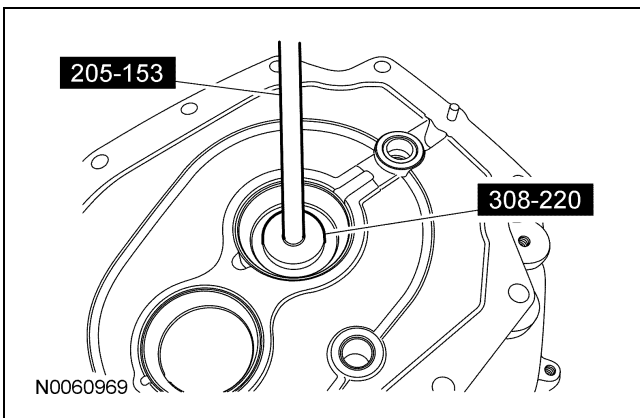

18. Install the input shaft and 4th gear synchronizer blocking ring.

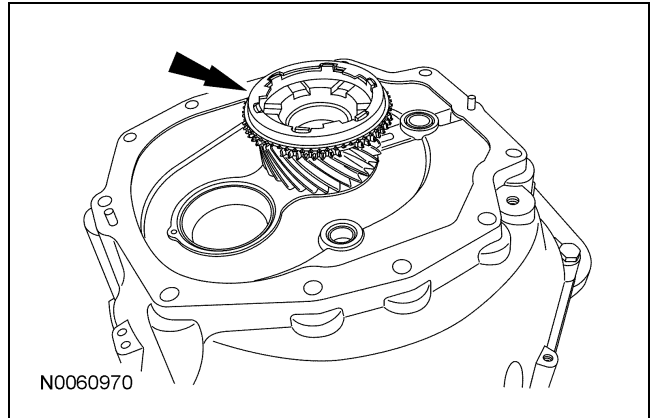

19. Assemble the shift rail assembly to the output shaft, then install the output shaft and shift rail as an assembly.

- Rotate the output shaft to engage the 4th gear synchronizer blocking ring with the synchronizer keys.

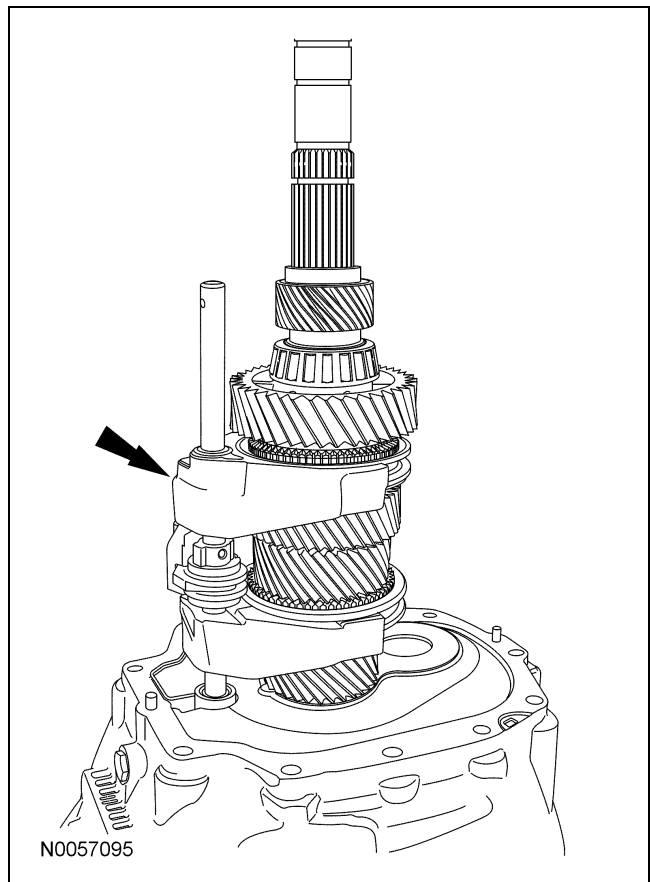

DISASSEMBLY AND ASSEMBLY (Continued)

20. Lift up the output shaft, then install the countershaft.

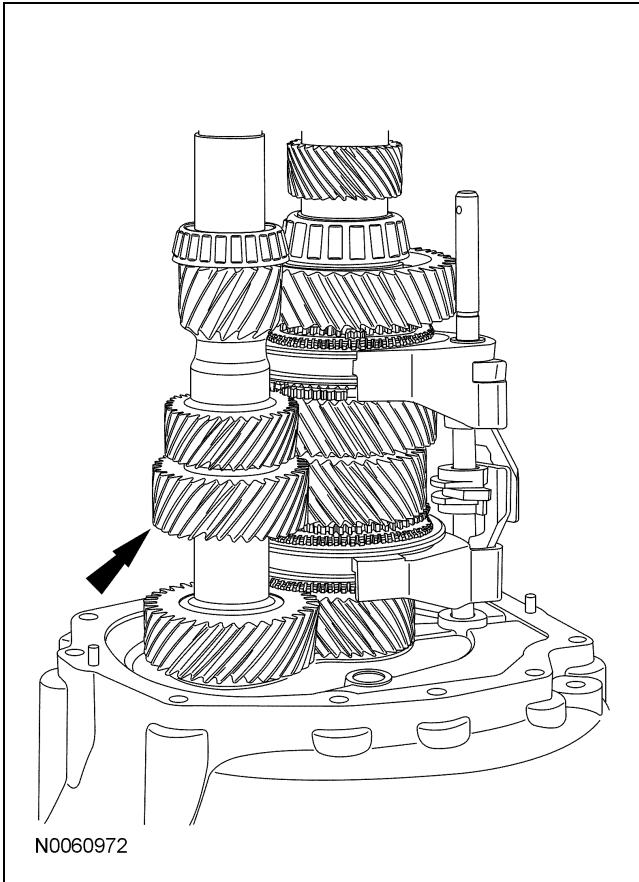

22. Install the 5th/6th and reverse shift rail assembly and align the slots of the shift levers with the shift interlock plate.

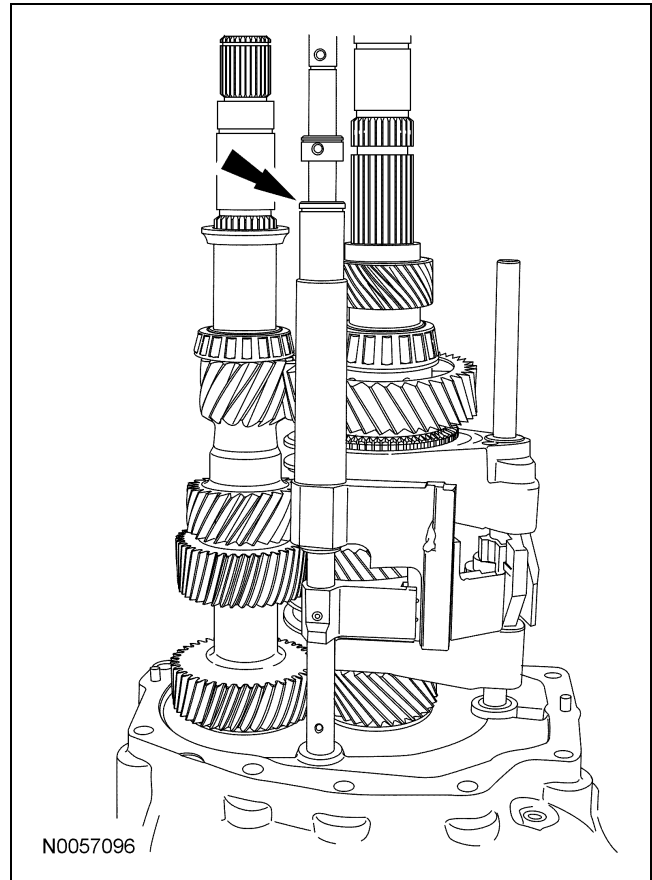

21. Install the 6th gear spacer and thrust washer.

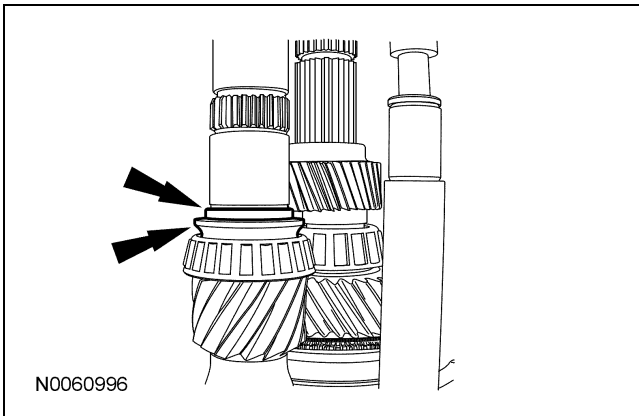

DISASSEMBLY AND ASSEMBLY (Continued)

23. Clean the mating surfaces of the transmission main case and the transmission clutch housing. Apply a bead of silicone rubber to the sealing surface on the transmission clutch housing. Install the transmission main case and the front offset lever.
- Make sure the transmission is in NEUTRAL to keep the 3rd/4th gear shift rail from engaging. Check for correct alignment of roller with top shift rail.
 - Tighten the bolts in a star pattern to 48 Nm (35 lb-ft).

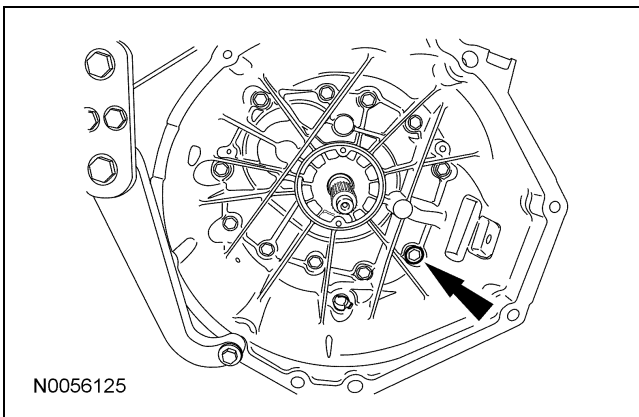
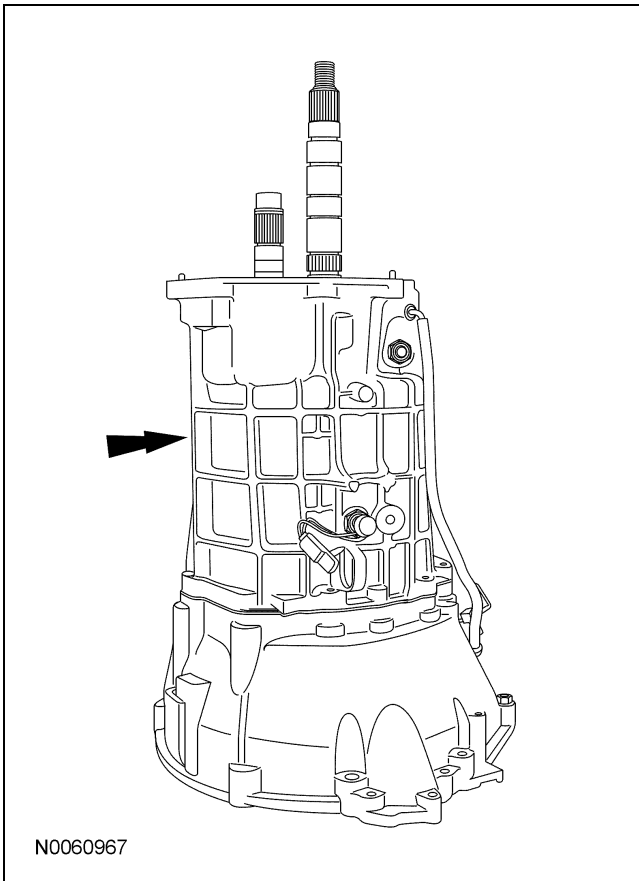

24. Apply threadlock to the threads of the shift lever guide bolts, then install the bolts.
- Tighten to 27 Nm (20 lb-ft).
 - Pull up on the 5th/6th shift rail to align the slot of the interlock plate with the guide bolt hole.

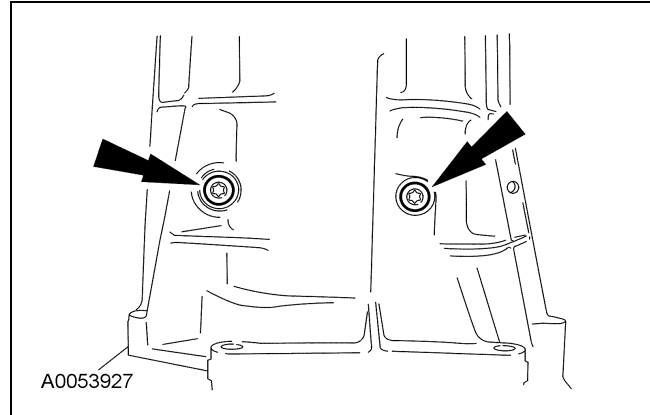

25. Install a new front offset lever roll pin.
- Install the pin until it is flush with the lever.
26. Apply threadlock to the threads of the shift detent, then install the shift detent assembly.
- Tighten to 40 Nm (30 lb-ft).

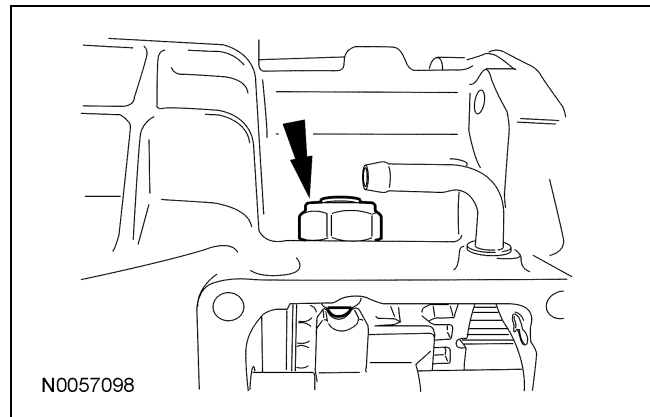

27. Install the 5th/6th gear needle bearing.

DISASSEMBLY AND ASSEMBLY (Continued)

28. Install 5th/6th gear, then install the 5th/6th gear synchronizer double cone and blocking ring as an assembly.

- Before installing the blocking ring, index-mark the blocking ring to the synchronizer hub.

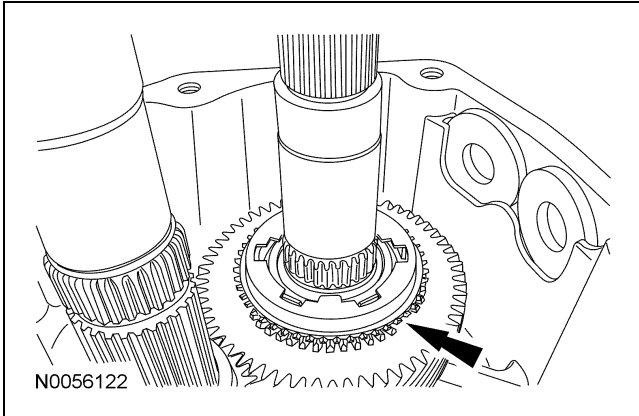

29. Install the 5th/6th gear shift fork and the 5th/6th gear synchronizer as an assembly.

- The synchronizer hub has a tight fit on the shaft, and may need to be installed separately.
- Make sure the synchronizer hub is correctly aligned with the blocking ring.

30. Install the new 5th/6th shift fork snap ring.

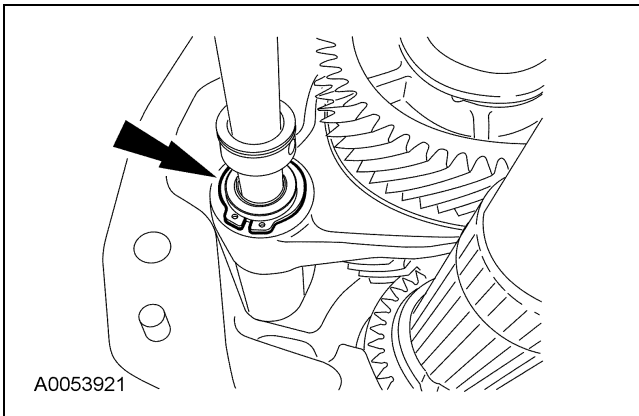

31. Install a new snap ring on the countershaft.

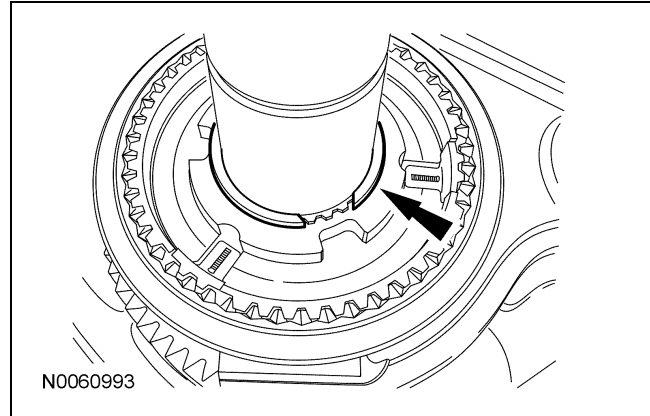

32. Install the 5th/6th gear synchronizer double cone and blocking ring as an assembly.

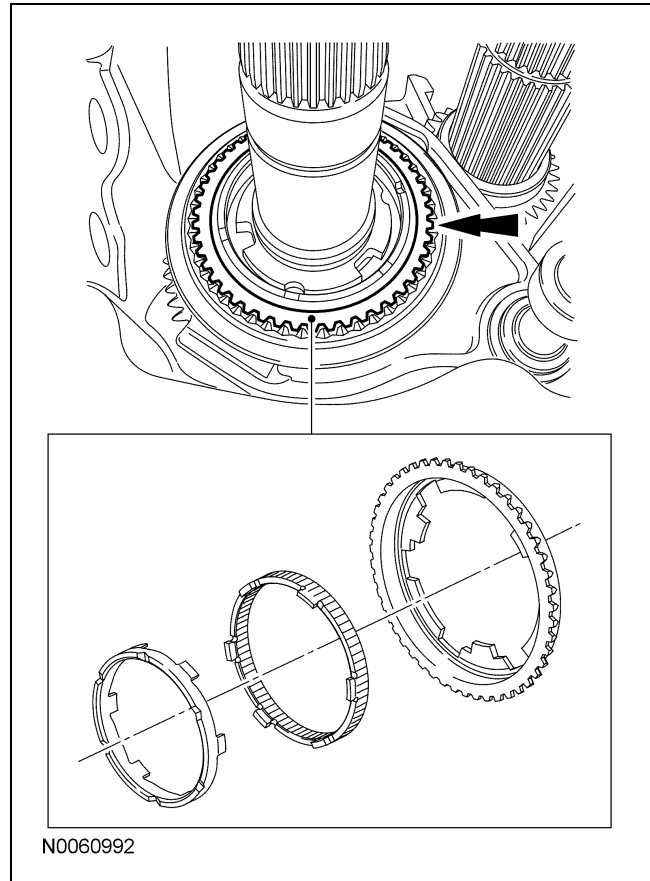

DISASSEMBLY AND ASSEMBLY (Continued)

33. Install the spacer and the 5th drive gear needle bearing.

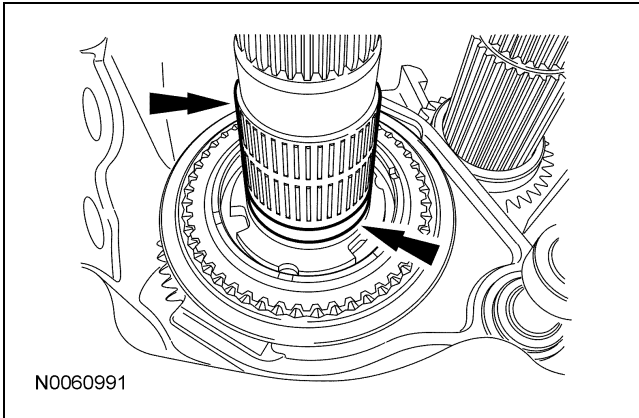

34. Install the following components:

- The 5th drive gear.
- The 5th drive gear thrust washer.
- A new 5th drive gear snap ring.

35. Using a suitable driver, install the reverse drive gear.

36. Install a new reverse drive gear snap ring.

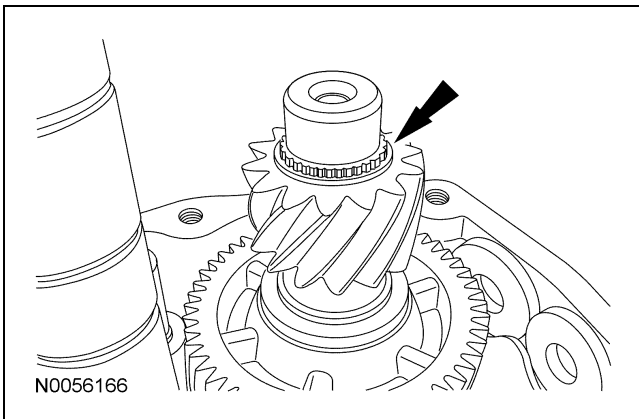

37. Using a suitable tool, press the 5th driven gear.

- Align the splines of the 5th driven gear with the drive gear on the countershaft extension.

38. Install the split ring and retainer.

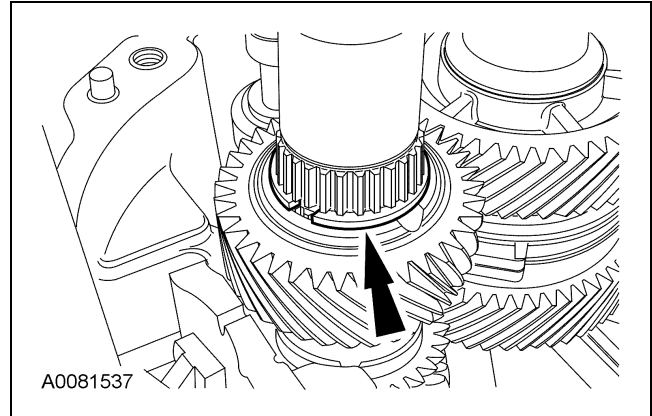

39. Install the reverse shift fork, the reverse synchronizer and the strut retainer as an assembly.

- The synchronizer hub has a tight fit on the shaft and may need to be installed separately.

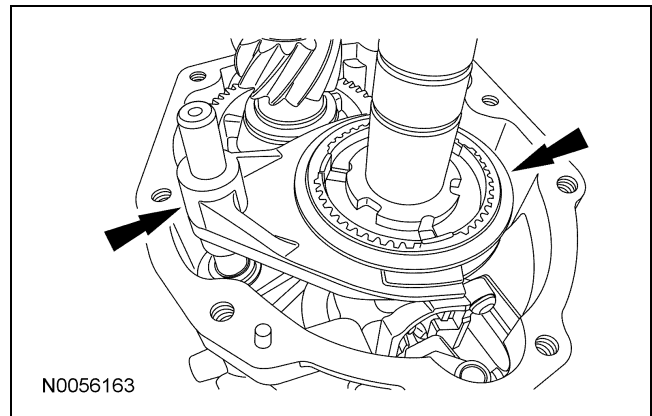

40. Install a new reverse shift fork snap ring.

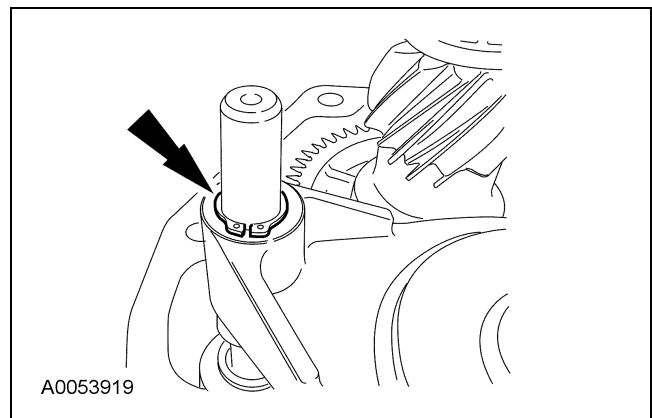

41. Install a new reverse gear synchronizer snap ring.

DISASSEMBLY AND ASSEMBLY (Continued)

42. Install the reverse gear synchronizer blocking rings.

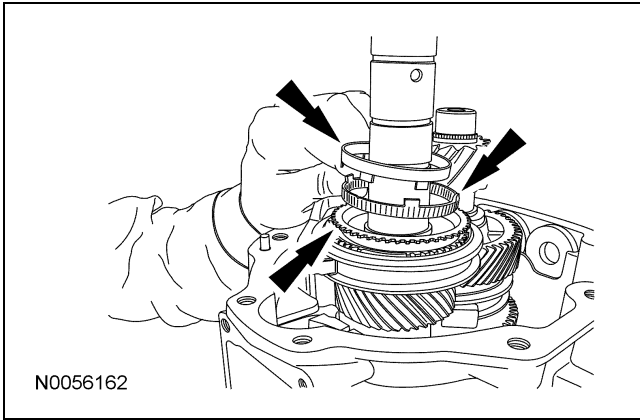

45. Install the reverse gear thrust washer.

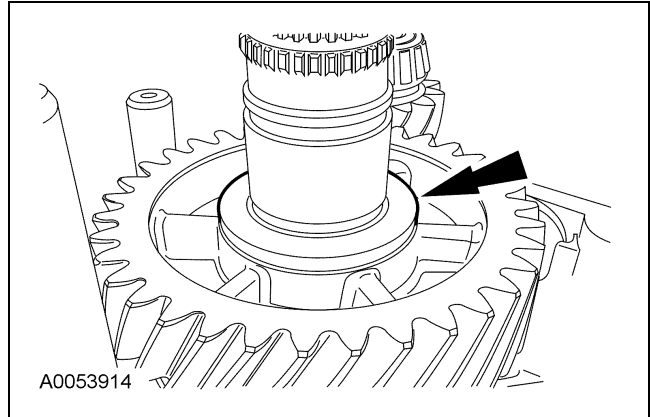

43. Install the reverse gear needle bearing.

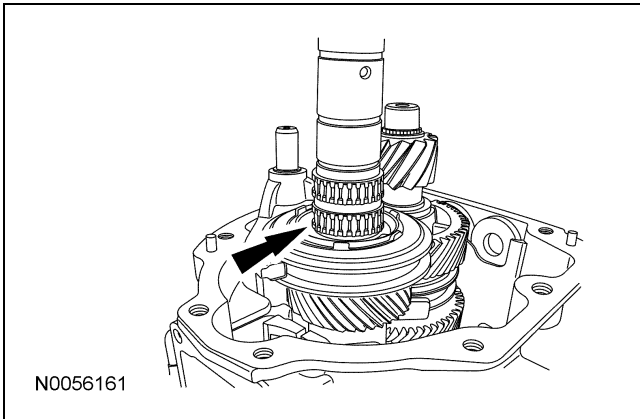

46. Install a new reverse gear snap ring.

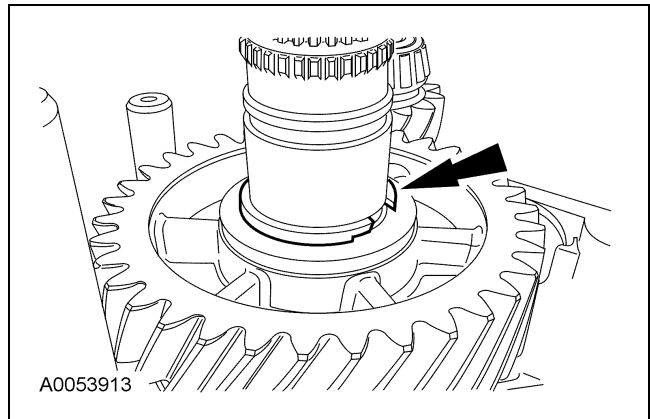

44. Install reverse gear.

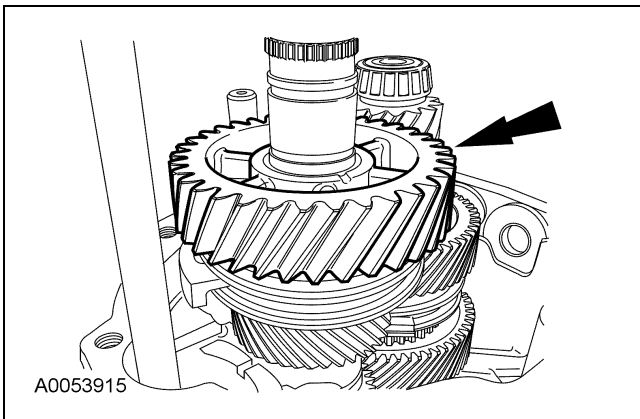

47. Install the lower spacer, the rear output shaft roller bearing and the upper spacer.

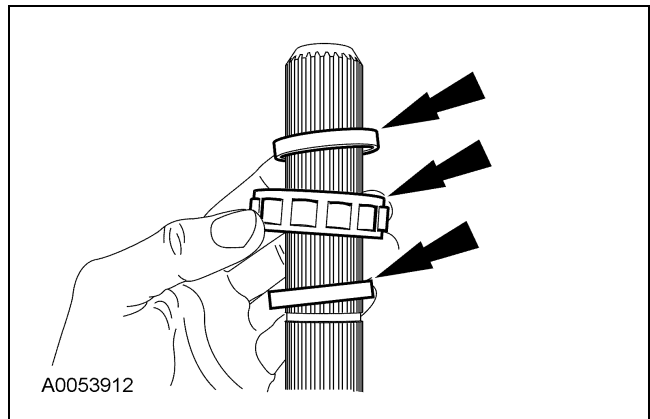

DISASSEMBLY AND ASSEMBLY (Continued)

48. Install a new rear output shaft roller bearing snap ring.

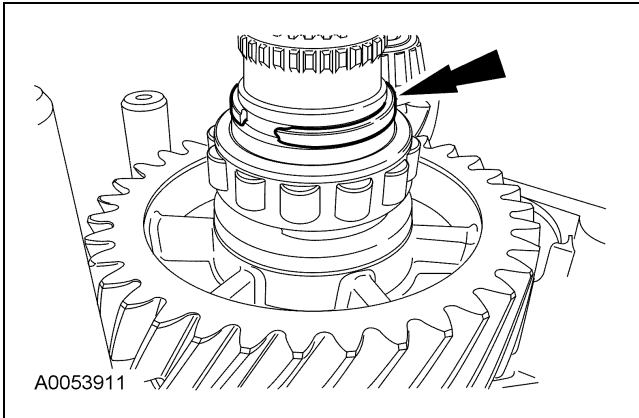

49. Position the check ball on the shaft. Install the Output Shaft Speed (OSS) sensor tone wheel. Install a new OSS sensor tone wheel retaining ring.
50. Install the reverse shift rail, then install a new reverse shift rail roll pin.
- Install the pin until it is flush with the lever.
51. Install the bearing spacer and the race.

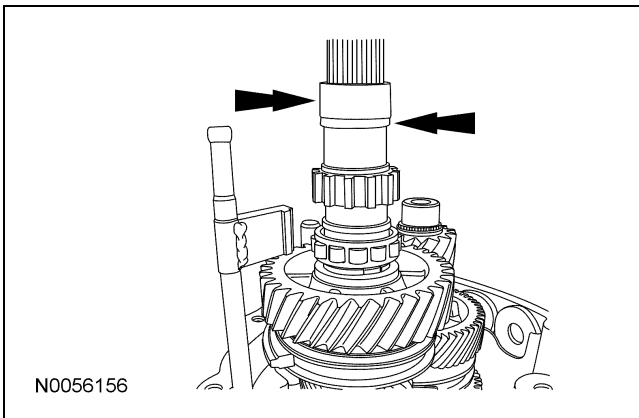

52. Clean the mating surfaces of the transmission main case and the extension housing. Apply a bead of silicone rubber to the sealing surface on the transmission case. Install the extension housing and tighten the bolts.
- Tighten to 48 Nm (25 lb-ft).
53. Install the vent hose.
54. Install the shift detent cover and the 4 shift detent cover bolts.
- Tighten to 20 Nm (177 lb-in).

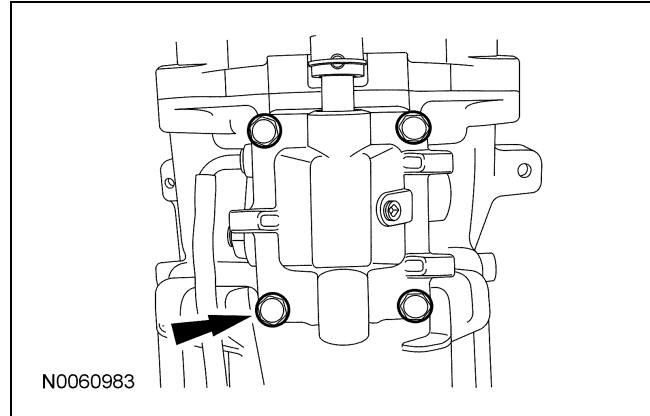

55. Install the output shaft flange.
56. Install the output shaft flange nut as follows:
- Using the old flange nut, tighten to 135 Nm (100 lb-ft).
 - Remove the nut and discard.
 - Install a new flange nut and tighten to 142 Nm (105 lb-ft).

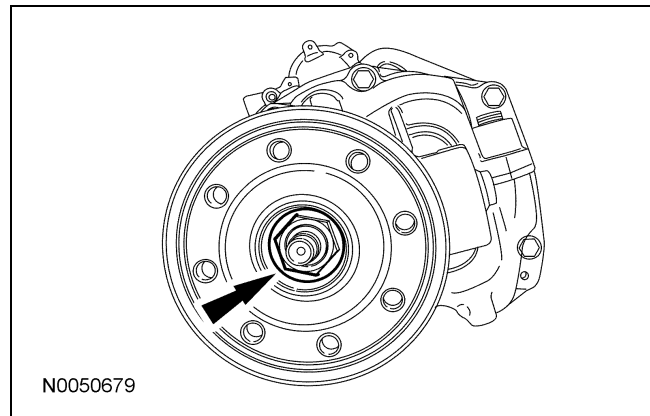

57. Apply thread sealer to the plug threads. Install the drain plug.
- Tighten to 27 Nm (20 lb-ft).

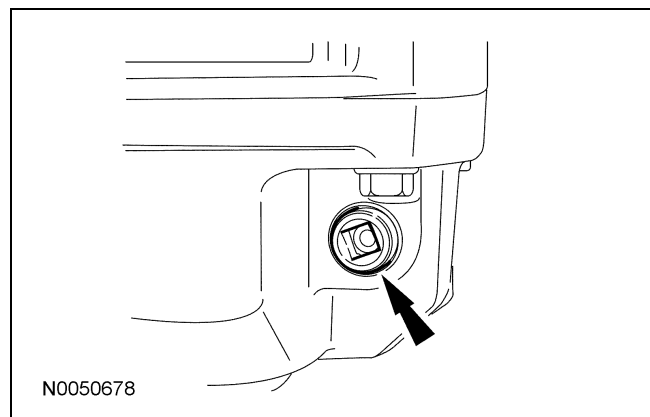

DISASSEMBLY AND ASSEMBLY (Continued)

58. Install the clutch slave cylinder and the 2 clutch slave cylinder bolts.

- Tighten to 12 Nm (106 lb-in).

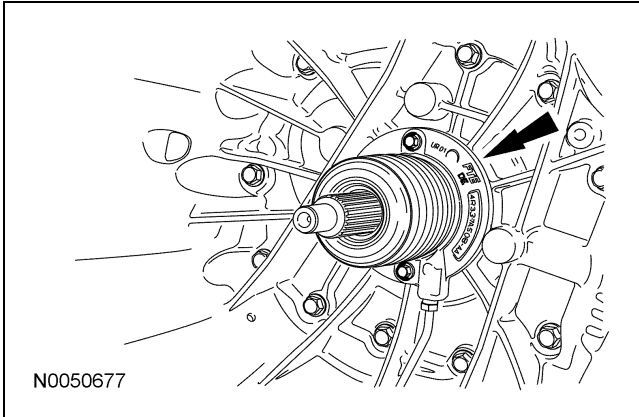

59. Install the clutch hydraulic tube and clip to the connector.

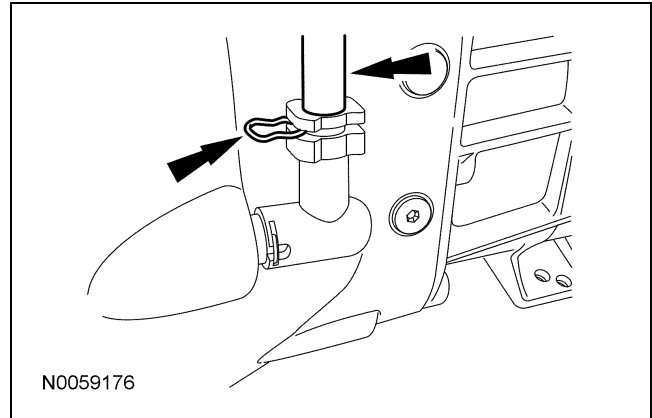

REMOVAL AND INSTALLATION

Transmission

Material

Item	Specification
MERCON® V Automatic Transmission Fluid XT-5-QM (or XT-5-QMC) (US); CXT-5-LM12 (Canada)	MERCON® V
Premium Long-Life Grease XG-1-C or XG-1-K (US); CXG-1-C (Canada)	ESA-M1C75-B
Threadlock and Sealer TA-25	WSK-M2G351-A5

Installation

- If removed, install the gearshift lever assembly.
 - Tighten to 40 Nm (30 lb-ft).
- If removed, install the transmission mount and the rear transmission insulator center bolt.
 - Tighten to 70 Nm (52 lb-ft).
- NOTE:** Before installing the transmission, the input shaft must be cleaned and lightly lubricated with grease.
NOTE: When installing the transmission with the gearshift lever attached, position the gear shifter into NEUTRAL position, so that the shifter will not damage the shift boot.
Install the transmission at a 45-degree angle. With the input shaft in the pilot bearing, rotate the transmission counterclockwise 45 degrees. Align the dowels and install.
- Install the 2 rear gearshift lever nuts.
 - Tighten to 20 Nm (177 lb-in).

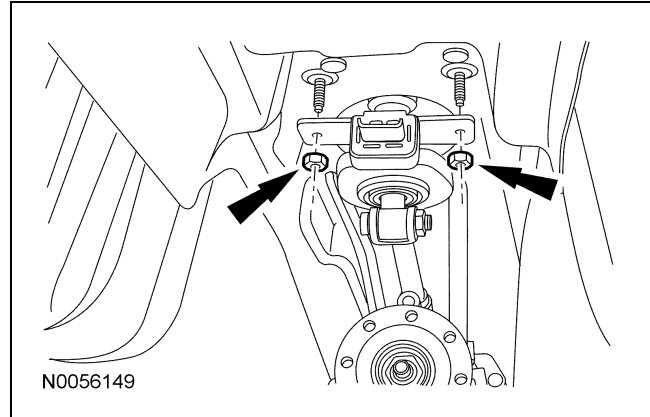

- Raise the transmission.
- NOTE:** Insert the clutch hydraulic tube into the clutch slave cylinder and install the clip before tightening the transmission-to-engine bolts.
Install the 7 transmission-to-engine bolts.
 - Tighten to 45 Nm (33 lb-ft).
- Remove the under hoist stand and the block of wood from the oil pan. Attach the wire harness at the front of the engine oil pan.
- NOTE:** The crossmember hump side goes up.
Install the transmission crossmember. For additional information, refer to Section 502-00.
- Connect the electrical connectors to the RH side of the transmission. Attach the harness to the transmission.
- Connect the electrical connectors to the LH side of the transmission. Attach the harness to the transmission.

REMOVAL AND INSTALLATION (Continued)

11. Install the subframe cross brace and the 4 subframe cross brace bolts.
- Tighten to 48 Nm (35 lb-ft).

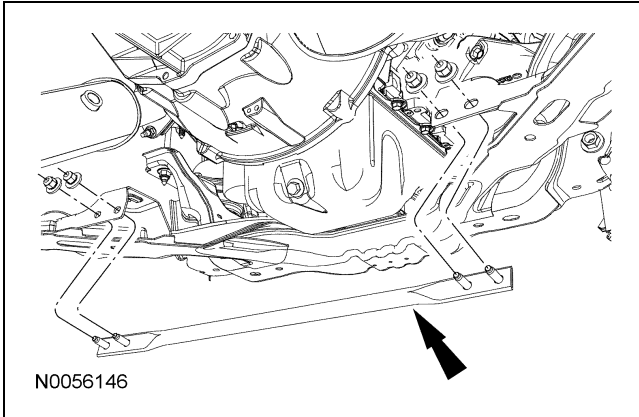

12. **NOTE:** Clean the starter motor mounting flange and mating surface of the starter motor to make sure of proper ground connection.
Install the starter motor. For additional information, refer to Section 303-06.
13. Install the catalytic converter assembly (H-pipe). For additional information, refer to Section 309-00.
14. **NOTE:** Align the index marks on the driveshaft flange and pinion flange, and the driveshaft flange and transmission output shaft flange.
Install the driveshaft. For additional information, refer to Section 205-01.

15. Install the upper gearshift lever and upper gearshift lever bolts.
- Tighten to 35 Nm (26 lb-ft).

16. Install the gearshift lever knob and boot.

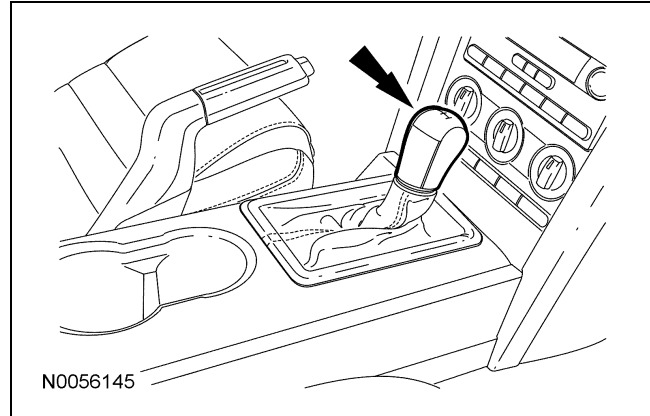

17. Connect the battery ground cable. For additional information, refer to Section 414-01.
18. Check, and as necessary, fill the transmission with transmission fluid. The total fill capacity is 3.46L (3.65 qt). Apply threadlock and sealer to the filler plug threads and install the filler plug.
- Tighten to 25 Nm (18 lb-ft).
19. Fill the brake and clutch reservoir. Bleed the clutch hydraulic system. For additional information, refer to Section 308-00.

SPECIFICATIONS

Material

Item	Specification	Fill Capacity
High Performance DOT 3 Motor Vehicle Brake Fluid PM-1-C (US); CPM-1-C (Canada)	WSS-M6C62-A or WSS-M6C65-A1	—

General Specifications

Item	Specification
Clutch Disc (4.0L)	
Clutch diameter	254 mm (10.0 in)
Color identification	none
Number of springs	5 ^a
Clutch Disc (4.6L)	

General Specifications (Continued)

Item	Specification
Clutch diameter	280 mm (11.0 in)
Color identification	none
Number of springs	4
Clutch Disc (5.4L)	
Clutch diameter	218 mm (8.5 in)
Number of discs	2 ^b
Number of springs	6
Pressure Plate	
Pressure spring	Belleville
Sensor spring	Belleville

a Inner floating damper design.

b Serviced as assembly only.

DESCRIPTION AND OPERATION

Manual Transmission and Clutch

The transmission and clutch system consist of the following:

- Manual transmission
 - T5OD is used with the 4.0L engine.
 - TR3650 is used with the 4.6L engine.
 - TR6060 is used with the 5.4L engine.
- Clutch disc
- Clutch pressure plate
- Clutch release hub and bearing
- Clutch hydraulic system
- Pilot bearing
- Flywheel

Power is delivered from the engine flywheel to the transmission. The power is transmitted through a driver-operated clutch, which allows for engagement and disengagement of the engine to the transmission.

The transmission input shaft receives the power when the clutch is engaged. The transmission then uses a system of gears to change the speed and torque relationship between the engine crankshaft and the transmission output shaft.

The purpose of the clutch is to connect and disconnect a manually operated transmission, and the remainder of the driveline system, from the engine. This allows starting and stopping the vehicle, shifting and changing speeds that correspond to the engine speed through gear reductions.

The clutch with the 4.0L or 4.6L engine is a single-plate, dry-friction disc with a diaphragm-style spring pressure plate. The 5.4L clutch is a dual disc clutch and pressure plate that is serviced as an assembly.

The manual transmission has a tag to identify assemblies for repair purposes. Refer to Section 308-03A, Section 308-03B or Section 308-03C for the transmission tag information.

DIAGNOSIS AND TESTING

Manual Transmission and Clutch

Principles of Operation

The transmission function is to move the vehicle from a rest position to motion. This is done by transferring the engine torque to the vehicle rear wheels. The transmission uses gears to adapt the torque to the demands of load and road conditions. It matches engine power to vehicle needs. This power is delivered from the engine flywheel to the transmission. The power is transmitted through a driver-operated clutch, which allows for engagement and disengagement of the engine to the transmission.

The transmission input shaft receives the power when the clutch is engaged. The transmission then uses a system of mainshaft gears to change the speed and torque relationship between the engine crankshaft and the transmission output shaft.

The clutch master cylinder transmits fluid pressure to the clutch slave cylinder, which in turn moves the clutch release bearing. The clutch hydraulic system uses brake fluid and shares a reservoir with the brake system. The clutch disc has frictional material where it contacts the flywheel and the clutch pressure plate. The clutch pressure plate applies pressure to the clutch disc, holding it tightly against the surface of the flywheel.

In the engaged position, the clutch pressure plate diaphragm spring holds the clutch pressure plate against the clutch disc, so that the engine torque is transmitted to the input shaft. When the clutch is depressed, movement is transmitted through the clutch hydraulic system, which actuates the clutch release bearing. The clutch release bearing pushes on the spring center toward the flywheel. The diaphragm spring pivots at the fulcrum, relieving the load on the clutch pressure plate. Steel spring straps riveted in the clutch pressure plate cover pull the clutch pressure plate from the clutch disc, disengaging the engine torque from the transmission.

Inspection and Verification

NOTICE: If transmission noise is reported, first check the fluid level. The vehicle should not be driven if the fluid level is low. A low fluid level will damage the transmission.

NOTE: Before attempting to rectify any concerns, road test the vehicle to ascertain in which system the concern falls.

NOTE: If an obvious cause for an observed or reported concern is found, correct the cause (if possible) before proceeding.

A gear driven unit will produce a certain amount of noise. Some noise is acceptable and audible at certain speeds or under various driving conditions. Certain conditions, such as road and weather, will amplify normal vehicle noise.

The following overview is a guide to diagnose a transmission/clutch concern:

- Verify and document the customer concern.
 - During the customer interview, if a leak was noticed or if a leak is the concern, check the transmission fluid. The vehicle should not be driven if the fluid level is low.
- Check fluid level and condition.
- Evaluate the clutch hydraulic system.
- Evaluate the clutch.
- Inspect gearshift mechanism.
- Evaluate the transmission.
- Find the cause of the problem and correct it.

Verify Customer Concern

1. Verify and document the customer concern.
 - 1 When was it first noticed?
 - 2 Did it appear suddenly or gradually?
 - 3 Did anything unusual occur that would coincide with it or precede it?
 - 4 Identify when the condition occurs:
 - Hot or cold vehicle operating conditions.
 - Type of terrain.
 - City/highway driving.
 - Driving at a particular speed.
 - coasting.
 - hard acceleration.

DIAGNOSIS AND TESTING (Continued)

- Shifting.
 - upshifts.
 - downshifts.
 - in a particular gear.
 - in all gears.
 - Hot or cold ambient temperatures.
- 5 Has the transmission/clutch been repaired before or components installed?
- Check the vehicle service record. Note any repairs.

Check Fluid Level and Condition

NOTICE: The vehicle should not be driven if the fluid level is low or damage may occur.

NOTICE: Excessive temperatures may break down the transmission lubricant. If there is reason to believe that the transmission has been subjected to temperatures exceeding 135°C (275°F), change the lubricant immediately.

An incorrect level may affect the transmission operation and can result in transmission damage. To correctly check and add fluid to the transmission, refer to Specifications in this section.

A low fluid level can result in poor transmission shifting, engagement or damage. It can also indicate a leak in one of the transmission seals or gaskets.

1. Check the fluid condition.
 - Observe the color and the odor of the fluid. Allow the fluid to drip onto a white cloth and examine the stain. Check the fluid for contamination or metal particles.
 - Fluid should appear reddish in color.

Evaluate Clutch Hydraulic System

1. Verify that the clutch hydraulic fluid reservoir is filled to the correct level.
 - If the fluid level is correct, proceed to clutch check.
 - If the fluid level is low, add fluid as necessary. Check the clutch hydraulic system for leaks and repair as necessary.

Evaluate the Clutch

1. Depress and release the clutch pedal slowly to check if the pedal is binding. Make sure the clutch pedal can be fully depressed and is not restricted by the floor mat.

2. Measure the clutch reserve. [GO to Pinpoint Test C.](#)
3. With the engine idling, the parking brake on and the clutch pedal up, gently move the gearshift lever forward into and out of REVERSE gear, until gear clash can be heard. Depress the clutch pedal slowly.
 - If the gears cease to clash (full disengage at 25.4-38.1 mm [1-5 in] from the floor), then hold the pedal at the point of disengagement and increase engine to 4,000 rpm. If the clutch remains disengaged, the clutch is OK.
 - Any concerns indicate a worn or damaged clutch. Repair as necessary.
4. With the engine idling, move the gearshift lever into 4th gear. Increase the rpm to 2,000 and slowly release the clutch pedal.
 - If the engine stalls, clutch is OK.
 - If the engine does not stall, clutch slipping. Repair as necessary.
5. Compare the clutch evaluation results with the following table. The following list of conditions are typical faults into which clutch concerns will fall.

Symptom Chart

Conditions/Sources	Action
<ul style="list-style-type: none"> • Clutch Slippage <ul style="list-style-type: none"> — Clutch pedal reserve — Diaphragm springs — Clutch pressure plate — Clutch disc facing — Hardened or oiled clutch disc facing surface — Flywheel 	<ul style="list-style-type: none"> • GO to Pinpoint Test A.
<ul style="list-style-type: none"> • Clutch Chatter or Shudder <ul style="list-style-type: none"> — Engine mounts — Oil on clutch disc facing — Diaphragm springs — Clutch pressure plate — Clutch disc facing — Flywheel — Clutch disc 	<ul style="list-style-type: none"> • GO to Pinpoint Test B.

DIAGNOSIS AND TESTING (Continued)**Symptom Chart (Continued)**

Conditions/Sources	Action
<ul style="list-style-type: none"> • Clutch Pedal Feels Spongy or Has Excessive Travel. Clutch Will Not Disengage <ul style="list-style-type: none"> — Insufficient clutch fluid — Air in hydraulic system — Clutch pedal reserve — Diaphragm springs — Clutch disc — Clutch disc splines — Oil on facing 	<ul style="list-style-type: none"> • GO to Pinpoint Test C.
<ul style="list-style-type: none"> • Clutch Drag, Also Hard to Shift <ul style="list-style-type: none"> — Insufficient clutch fluid — Air in hydraulic system — Clutch pedal reserve — Diaphragm springs — Clutch disc — Transmission concern 	<ul style="list-style-type: none"> • GO to Pinpoint Test D.
<ul style="list-style-type: none"> • Clutch Pedal Pulsation <ul style="list-style-type: none"> — Clutch and brake pedal pivot shaft not correctly lubricated — Flywheel — Worn springs in pressure plate 	<ul style="list-style-type: none"> • GO to Pinpoint Test E.
<ul style="list-style-type: none"> • Clutch-Related Vibrations <ul style="list-style-type: none"> — Engine component grounding against frame — Accessory drive belt — Flywheel bolts — Flywheel — Imbalanced clutch pressure plate 	<ul style="list-style-type: none"> • GO to Pinpoint Test F.
<ul style="list-style-type: none"> • Excessive Noise <ul style="list-style-type: none"> — Clutch pedal reserve — Clutch slave cylinder — Pilot bearing — Excessive crankshaft end play 	<ul style="list-style-type: none"> • GO to Pinpoint Test G.

Symptom Chart (Continued)

Conditions/Sources	Action
<ul style="list-style-type: none"> • Clutch System Leakage <ul style="list-style-type: none"> — Clutch master cylinder — Clutch slave cylinder — Clutch hydraulic tubes 	<ul style="list-style-type: none"> • GO to Pinpoint Test C.
<p>If the clutch was the concern, REPAIR the clutch system. TEST the system for normal operation.</p>	

Inspect the Gearshift Mechanism

1. Inspect the gearshift mechanism for:
 - signs of damage.
 - missing or loose fasteners.
 - binding.
2. Repair any concerns as necessary.

Evaluate the Transmission

1. During the road test, use the following driving methods to diagnose the concern.
 - Start the engine.
 - Evaluate the noise in NEUTRAL while the vehicle is parked.
 - Check whether the noise is present with the clutch fully disengaged (pedal fully depressed). Check to see if the pedal pulsates abnormally (for clutch diaphragm finger runout).
 - Check whether the noise is present with the gearshift in the NEUTRAL position and the clutch fully engaged (foot off pedal). With the parking brake engaged, move the gearshift towards the 1st gear position. Apply very slight pressure and note if the gear noise level is reduced. (for gear rollover noise).
 - With the clutch fully engaged (foot off pedal) check whether the noise is present as the engine speed is raised. If the noise reduces, note the engine speed at which this occurs.
 - Listen for any change in noise while depressing and releasing the clutch pedal.
 - Listen for any change in noise while changing the engine rpm.

DIAGNOSIS AND TESTING (Continued)

- Drive the vehicle and shift through all of the gear ranges, including REVERSE. Listen for any change in noise in a particular gear.
 - Drive the vehicle in the gear in which the noise is most noticeable. Depress the clutch pedal and leave the gear engaged. Listen for any change in noise.
 - Drive the vehicle in the gear in which the noise is most noticeable. Depress the clutch pedal and shift the transmission into NEUTRAL. Release the clutch pedal and allow the vehicle to coast.
- Compare the noise to another vehicle. Make sure the transmissions are the same.
2. Compare the road test results with the following symptom charts. Included is a list of conditions that are typical faults into which the transmission will fall:
GO to [Symptom Chart — Transmission Operation](#) or GO to [Symptom Chart — NVH](#) in this section.

Symptom Chart — Transmission Operation**Symptom Chart — Transmission Operation**

Condition	Possible Sources	Action
<ul style="list-style-type: none"> • Transmission difficult to shift 	<ul style="list-style-type: none"> • Lubricant • Internal shift mechanism • Sliding gears, synchronizers • Housings, shaft • Loose pressure plate to flywheel bolts 	<ul style="list-style-type: none"> • ADD or DRAIN and FILL with specified lubricant. • CHECK the internal shift mechanism for smooth operation. REPAIR or INSTALL a new mechanism as necessary. • CHECK for free movement of gears and synchronizers. REPAIR or INSTALL new components as necessary. • CHECK for binding condition between the input shaft and the engine crankshaft pilot bearing or bushing. REPAIR or INSTALL new components as necessary. Refer to the appropriate section in Group 308 for the procedure. • CHECK for loose bolts at the pressure plate. INSTALL new components as necessary. REFER to Section 308-01.
<ul style="list-style-type: none"> • Transmission will not shift — gearshift lever moves 	<ul style="list-style-type: none"> • Gearshift lever damaged • Damaged or worn offset lever, shift plate or selector arm. Loose shift rail bushings 	<ul style="list-style-type: none"> • INSTALL a new gearshift lever. • CHECK the internal shift components. INSTALL new component as necessary.

DIAGNOSIS AND TESTING (Continued)**Symptom Chart — Transmission Operation (Continued)**

Condition	Possible Sources	Action
<ul style="list-style-type: none"> Gears clash when shifting from one forward gear to another 	<ul style="list-style-type: none"> Pilot bearing Gear teeth and/or synchronizer Damaged shift forks or worn shift fork inserts 	<ul style="list-style-type: none"> CHECK for a binding condition between the input shaft and the engine crankshaft pilot bearing. INSTALL new components as necessary. REFER to Section 308-01. REPAIR or INSTALL new components as necessary. Refer to the appropriate section in Group 308 for the procedure. INSPECT for wear or damage. INSTALL new components as necessary. Refer to the appropriate section in Group 308 for the procedure.
<ul style="list-style-type: none"> Transmission jumps out of gear 	<ul style="list-style-type: none"> Transmission range selector lever boot Transmission-to-engine mounting bolts Crankshaft pilot bearing Internal damage Gear teeth 	<ul style="list-style-type: none"> INSTALL a new boot if exceptionally stiff. Refer to the appropriate section in Group 308 for the procedure. TIGHTEN the bolts to specification. INSTALL a new bearing. INSPECT the synchronizer sleeves for free movement on their hubs. INSPECT the synchronizer blocking rings for widened index slots, rounded clutch teeth and smooth internal surface. CHECK countershaft cluster gear for excessive end play. CHECK shift forks for worn or loose mounting on shift rails. INSPECT the synchronizer sliding sleeve and the gear clutch teeth for wear or damage. REPAIR or INSTALL a new component as necessary. If worn or damaged, INSTALL new gears. Refer to the appropriate section in Group 308 for the procedure.

DIAGNOSIS AND TESTING (Continued)**Symptom Chart — Transmission Operation (Continued)**

Condition	Possible Sources	Action
<ul style="list-style-type: none"> Transmission will not shift into one gear — all others OK 	<ul style="list-style-type: none"> Manual shift linkage Backup switch ball Internal components 	<ul style="list-style-type: none"> REPAIR or INSTALL new components as necessary. If REVERSE is the problem, CHECK reverse lamp switch for ball frozen in extended position. INSPECT the shift rail and fork system, synchronizer system and the gear clutch teeth for restricted travel. REPAIR or INSTALL new components as necessary.
<ul style="list-style-type: none"> Transmission is locked in one gear and cannot be shifted out of that gear 	<ul style="list-style-type: none"> Internal components Fork on rail, offset lever or shift rail 	<ul style="list-style-type: none"> INSPECT the problem gears, shift rails, forks and the synchronizer for wear or damage. REPAIR as necessary. Refer to the appropriate section in Group 308 for the procedure. CHECK the shift rail interlock system. REPAIR as necessary. Refer to the appropriate section in Group 308 for the procedure.
<ul style="list-style-type: none"> Transmission leaks 	<ul style="list-style-type: none"> Lubricant Other component leaking False report Internal components Fill and drain plugs 	<ul style="list-style-type: none"> CHECK the level and type. IDENTIFY leaking fluid as engine, power steering or transmission fluid. REPAIR as necessary. REMOVE all traces of lube on the exposed transmission surfaces. CHECK the vent for free breathing. OPERATE the transmission and INSPECT for new leakage. REPAIR as necessary. Refer to the appropriate section in Group 308 for the procedure. INSPECT for leaks at the input shaft bearing retainer seal and the shift rail expansion plug. Refer to the appropriate section in Group 308 for the procedure. INSPECT for leaks at the top cover gasket. INSPECT the case for sand holes or cracks. REPAIR or INSTALL a new case as necessary. Refer to the appropriate section in Group 308 for the procedure. CHECK fill and drain plugs and bore threads. REPAIR as necessary. TIGHTEN plugs to specified torque value. Refer to the appropriate section in Group 308 for the procedure.

DIAGNOSIS AND TESTING (Continued)**Symptom Chart — Transmission Operation (Continued)**

Condition	Possible Sources	Action
<ul style="list-style-type: none"> • Bearing failure 	<ul style="list-style-type: none"> • Other part failure • Raceways or rollers • Lubricant • Towing vehicle further than 80 km (50 mi) with driveshaft installed. Mainshaft tapered bearings and needle caged bearings are especially susceptible to damage • Vibration break-up of retainer and brinelling of races • Bearing(s) • Shafts or bore • Overloading of vehicle • Incorrect preload • Input shaft oil dam • Oil baffle in the input bearing shim pack 	<ul style="list-style-type: none"> • REMOVE, DISASSEMBLE and CLEAN the transmission. Inspect for damaged parts and install new components as necessary. (Note: RESET the bearing preload if any new tapered bearings are installed.) Refer to the appropriate section in Group 308 for the procedure. • DETERMINE the cause of vibration and CORRECT. Otherwise, PROCEED as above. • INSTALL new components as necessary and VERIFY the oil dam installation is correct. Refer to the appropriate section in Group 308 for the procedure. CHECK for correct installation of the snap ring on the mainshaft next to the oil dam. • INSTALL a new oil baffle, making sure it is not damaged during assembly. Refer to the appropriate section in Group 308 for the procedure.

DIAGNOSIS AND TESTING (Continued)**Symptom Chart — NVH****Symptom Chart — NVH**

NOTE: NVH symptoms should be identified using the diagnostic tools that are available. For a list of these tools, an explanation of their uses and a glossary of common terms, refer to Section 100-04. Since it is possible any one of multiple systems may be the cause of a symptom, it may be necessary to use a process of elimination type of diagnostic approach to pinpoint the responsible system. If this is not the causal system for the symptom, refer back to Section 100-04 for the next likely system and continue diagnosis.

Condition	Possible Sources	Action
<ul style="list-style-type: none"> Excessive noise 	<ul style="list-style-type: none"> Clutch disc damper damaged Transmission input shaft pilot bearing worn or damaged Crankshaft end play excessive Release bearing worn or damaged 	<ul style="list-style-type: none"> REMOVE the clutch disc and pressure plate. REFER to Section 308-01. INSPECT the clutch disc for damage. INSPECT the transmission input shaft pilot bearing for wear and damage. REFER to Pilot Bearing Check in this section. CHECK the crankshaft end play. Refer to the appropriate section in Group 303 for the procedure. CHECK the clutch release hub and bearing, and guide tube for wear and damage. REPAIR all components as necessary. TEST the system for normal operation.
<ul style="list-style-type: none"> Clutch rattling noise — occurs with clutch engaged, noise changes/disappears with clutch pedal depressed 	<ul style="list-style-type: none"> Flywheel bolts, clutch housing bolts or clutch pressure plate bolts loose 	<ul style="list-style-type: none"> TIGHTEN the bolts to specifications. CHECK the bolts for damage. REFER to Section 308-01.
<ul style="list-style-type: none"> Clutch squeaking noise — noise is heard when the clutch is operated. Vehicle moves slowly or creeps when the clutch is disengaged. Can also be difficult to shift into 1st and REVERSE gears 	<ul style="list-style-type: none"> Pilot bearing seized or damaged 	<ul style="list-style-type: none"> INSTALL a new pilot bearing. REFER to Section 308-01.
<ul style="list-style-type: none"> Clutch squeaking noise — occurs with clutch pedal depressed/released 	<ul style="list-style-type: none"> Worn clutch pedal shaft or bushings 	<ul style="list-style-type: none"> INSPECT the clutch pedal for wear or damage. REPAIR as necessary. REFER to Section 308-02.
<ul style="list-style-type: none"> Clutch whirring/rattle noise — occurs when clutch pedal is depressed 	<ul style="list-style-type: none"> Worn, damaged or misaligned clutch release bearing 	<ul style="list-style-type: none"> INSTALL a new clutch release bearing. REFER to Section 308-01.
<ul style="list-style-type: none"> Clutch grating/grinding noise — occurs when clutch pedal is depressed 	<ul style="list-style-type: none"> Clutch pressure plate fingers bent or worn Contact surface of clutch release bearing worn or damaged 	<ul style="list-style-type: none"> INSPECT the clutch pressure plate release fingers. INSTALL a new pressure plate as necessary. REFER to Section 308-01. INSTALL a new clutch release bearing. REFER to Section 308-01.

DIAGNOSIS AND TESTING (Continued)**Symptom Chart — NVH (Continued)**

Condition	Possible Sources	Action
<ul style="list-style-type: none"> Clutch chatter — a small amount of noise when clutch pedal is released at initial take-off 	<ul style="list-style-type: none"> Clutch engagement 	<ul style="list-style-type: none"> Acceptable operating condition.
<ul style="list-style-type: none"> Clutch chatter/grabs — in some cases a shudder is felt. Occurs with clutch pedal depressed/released 	<ul style="list-style-type: none"> Damaged or worn powertrain/driveline mounts Binding or dragging plunger of the clutch master cylinder or slave cylinder Grease or oil on the clutch disc facing Clutch disc surface glazed or damaged Damaged or worn clutch pressure plate Flywheel surface damaged or glazed 	<ul style="list-style-type: none"> INSPECT the powertrain/drivetrain mounts. INSTALL new mounts as necessary. Refer to the appropriate section in Group 303 for the procedure. CHECK the master and slave cylinder operation. INSPECT the components for damage or wear. INSTALL a new master or slave cylinder as necessary. REFER to Section 308-02. CHECK the input shaft seal and rear main oil seal. REPAIR as necessary. INSTALL a new clutch disc. REFER to Section 308-01. INSPECT the clutch disc surface for a glazed, hardened or damage condition. CARRY OUT a disc check. INSTALL a new clutch disc as necessary. REFER to Section 308-01. INSPECT the clutch pressure plate for wear or damage. INSTALL a new clutch pressure plate as necessary. REFER to Section 308-01. INSPECT the flywheel for damage or wear. CARRY OUT a flywheel runout check. INSTALL a new flywheel as necessary. Refer to the appropriate section in Group 303 for the procedure.
<ul style="list-style-type: none"> Clutch chatter noise — noise when clutch pedal is released at initial take-off. Clutch is hard to engage and disengage 	<ul style="list-style-type: none"> Pilot bearing worn, damaged or not correctly aligned in bore 	<ul style="list-style-type: none"> INSPECT the clutch pressure plate release fingers for uneven wear, clutch components burnt or a seized pilot bearing. INSTALL a new pilot bearing as necessary. REFER to Section 308-01.
<ul style="list-style-type: none"> Clutch chatter — a small amount of noise when the clutch is released at initial take-off. Occurs in 1st and/or REVERSE gear with the transmission at operating temperature (5.4L engines only) 	<ul style="list-style-type: none"> Clutch engagement 	<ul style="list-style-type: none"> Acceptable operating condition. Noise caused by the material used in the clutch disc.

DIAGNOSIS AND TESTING (Continued)**Symptom Chart — NVH (Continued)**

Condition	Possible Sources	Action
<ul style="list-style-type: none"> Clutch hiss — a small amount of noise during initial engagement of the clutch in 1st or REVERSE gear (5.4L engines only) 	<ul style="list-style-type: none"> Clutch engagement 	<ul style="list-style-type: none"> Acceptable operating condition. Noise caused by the clutch disc contacting the pressure plate and flywheel surfaces.
<ul style="list-style-type: none"> Transmission rattle noise — noise occurs at 1st and 2nd gear on light acceleration (5.4L engines only) 	<ul style="list-style-type: none"> Gear engagement 	<ul style="list-style-type: none"> Acceptable operating condition. Caused by the contact pattern of these gears.
<ul style="list-style-type: none"> Transmission rattling/clattering noise — occurs in NEUTRAL or in gear, at idle 	<ul style="list-style-type: none"> Incorrect fluid level or fluid quality 	<ul style="list-style-type: none"> CHECK that the transmission is filled to the correct level and with the specified fluid. REFER to Section 307-01 for the fluid type.
<ul style="list-style-type: none"> Transmission rattling/clattering noise — noise at idle in NEUTRAL 	<ul style="list-style-type: none"> Worn or rough reverse idler gear Excessive backlash in gears Worn countershaft gears 	<ul style="list-style-type: none"> CHECK the reverse idler gear. REPAIR as necessary. Refer to the appropriate section in Group 308 for the procedure. CHECK the gear backlash. ADJUST as necessary. Refer to the appropriate section in Group 308 for the procedure. REPAIR as necessary. Refer to the appropriate section in Group 308 for the procedure.
<ul style="list-style-type: none"> Transmission whine — a mild whine at extreme speeds or high rpm 	<ul style="list-style-type: none"> Rotating gears/geartrain 	<ul style="list-style-type: none"> Acceptable noise.
<ul style="list-style-type: none"> Transmission whine — a high pitched whine, also described as a squeal 	<ul style="list-style-type: none"> Transmission gears are worn (high mileage vehicle) Mismatched gear sets Damaged or worn transmission bearing 	<ul style="list-style-type: none"> Result of normal gear wear. REPAIR as necessary. Refer to the appropriate section in Group 308 for the procedure. INSPECT the gear sets for an uneven wear pattern on the face of the gear teeth. REPAIR as necessary. Refer to the appropriate section in Group 308 for the procedure. INSPECT the transmission bearings. INSTALL new bearings as necessary. Refer to the appropriate section in Group 308 for the procedure.
<ul style="list-style-type: none"> Transmission growling/humming — noise occurs in the forward gears. The noise is more prominent when the gear is loaded. The problem gear can be located as the noise occurs in a specific gear position 	<ul style="list-style-type: none"> Gear is cracked, chipped or rough 	<ul style="list-style-type: none"> INSPECT the transmission gears for damage or wear. INSTALL new gears as necessary. Refer to the appropriate section in Group 308 for the procedure.

DIAGNOSIS AND TESTING (Continued)**Symptom Chart — NVH (Continued)**

Condition	Possible Sources	Action
<ul style="list-style-type: none"> Transmission hissing — noise in NEUTRAL or in forward gears. As bearings wear or break up, the noise changes to a thumping noise 	<ul style="list-style-type: none"> Damaged or worn bearings 	<ul style="list-style-type: none"> INSPECT the transmission bearings. INSTALL new bearings as necessary. Refer to the appropriate section in Group 308 for the procedure.
<ul style="list-style-type: none"> Transmission knocking/thudding — noise at low speeds in forward gears 	<ul style="list-style-type: none"> Bearings with damaged balls or rollers or with pitted and spalled races 	<ul style="list-style-type: none"> INSPECT the transmission bearings. INSTALL new bearings as necessary. Refer to the appropriate section in Group 308 for the procedure.
<ul style="list-style-type: none"> Transmission rumble/growl — noise at higher speeds in forward gears, more pronounced in a coast/deceleration condition 	<ul style="list-style-type: none"> Incorrect driveline angle Driveshaft out of balance or damaged 	<ul style="list-style-type: none"> CHECK the driveline angle. REPAIR as necessary. REFER to Section 205-00. Refer to the appropriate section in Group 308 for the procedure. CHECK the driveshaft for damage, missing balance weights or undercoating. REFER to the driveshaft runout and balance test in Section 205-00.
<ul style="list-style-type: none"> Transmission rumble/growl — noise at all speeds in forward gears, more pronounced in a heavy acceleration condition 	<ul style="list-style-type: none"> Damaged or worn transmission bearing or gears (high mileage vehicles) 	<ul style="list-style-type: none"> CHECK transmission fluid for excessive metal particles. REPAIR as necessary.

Pinpoint Tests**Pinpoint Test A: Clutch Slippage****Normal Operation**

The clutch is designed to transfer the power from the engine to the transmission, which may be either stationary (starting) or rotating at a different speed (upshifting or downshifting). The clutch is functioning correctly when both the engine and transmission are rotating at the same speed with the clutch engaged. Clutch pedal movement is transmitted by fluid pressure, which actuates the clutch release hub and bearing. The clutch release hub and bearing pushes on the spring center towards the flywheel. The diaphragm spring pivots at the fulcrum, relieving the load on the clutch pressure plate. Steel spring straps riveted in the clutch pressure plate cover pull the clutch pressure plate from the clutch disc, disengaging the engine torque from the transmission.

This pinpoint test is intended to diagnose the following:

- Clutch pedal
- Clutch hydraulic system
- Clutch disc
- Clutch pressure plate

DIAGNOSIS AND TESTING (Continued)**PINPOINT TEST A: CLUTCH SLIPPAGE**

Test Step		Result / Action to Take
A1	INSPECT THE CLUTCH PEDAL	Yes GO to A2 . No INSPECT the clutch pedal. REFER to Section 308-02.
	<ul style="list-style-type: none"> Ignition OFF. Block the wheels and apply the parking brake. Depress and slowly release the clutch pedal. Does the clutch pedal release without binding? 	
A2	CHECK THE HYDRAULIC SYSTEM	Yes INSTALL a new clutch master cylinder. REFER to Section 308-02. No GO to A3 .
	<ul style="list-style-type: none"> Ignition OFF. Depress and release the clutch pedal. Is there residual hydraulic pressure at the bleed screw? 	
A3	CARRY OUT A STALL TEST	Yes The clutch is not slipping. VERIFY the customer concern. No INSPECT the clutch components for damage.
	<ul style="list-style-type: none"> Start the engine. Block the wheels and apply the parking brake. Place the transmission in 4th gear. Increase the engine speed to 2,000 rpm and slowly release the clutch pedal. Does the engine stall within 5 seconds? 	

Pinpoint Test B: Clutch Chatter or Shudder**Normal Operation**

The clutch is designed to transfer the power from the engine to the transmission, which may be either stationary (starting) or rotating at a different speed (upshifting or downshifting). The clutch is functioning correctly when both the engine and transmission are rotating at the same speed with the clutch engaged. Clutch pedal movement is transmitted by fluid pressure, which actuates the clutch release hub and bearing. The clutch release hub and bearing pushes on the spring center towards the flywheel. The diaphragm spring pivots at the fulcrum, relieving the load on the clutch pressure plate. Steel spring straps riveted in the clutch pressure plate cover pull the clutch pressure plate from the clutch disc, disengaging the engine torque from the transmission.

This pinpoint test is intended to diagnose the following:

- Engine or transmission mounts
- Clutch disc
- Clutch pressure plate
- Flywheel
- Pilot bearing
- Input shaft

PINPOINT TEST B: CLUTCH CHATTER OR SHUDDER

Test Step		Result / Action to Take
B1	CHECK THE ENGINE OR TRANSMISSION MOUNTS	Yes TIGHTEN or INSTALL new engine mounts or transmission mounts as necessary. TEST the system for normal operation. No GO to B2 .
	<ul style="list-style-type: none"> Inspect all the engine and transmission mounts for loose fasteners or damage. Are any of the engine or transmission mounts loose or damaged? 	

(Continued)

DIAGNOSIS AND TESTING (Continued)**PINPOINT TEST B: CLUTCH CHATTER OR SHUDDER (Continued)**

Test Step		Result / Action to Take
B2	INSPECT THE PRESSURE PLATE BOLTS	<p>Yes TIGHTEN or INSTALL new bolts as necessary. REFER to Section 308-01. TEST the system for normal operation.</p> <p>No GO to B3.</p>
	<ul style="list-style-type: none"> Inspect the pressure plate-to-flywheel bolts. Are any of the pressure plate-to-flywheel bolts loose? 	
B3	INSPECT THE PRESSURE PLATE	<p>Yes INSTALL a new clutch pressure plate. REFER to Section 308-01. TEST the system for normal operation.</p> <p>No GO to B4.</p>
	<ul style="list-style-type: none"> Remove the clutch pressure plate. Refer to Section 308-01. Inspect the clutch pressure plate. Refer to Clutch Pressure Plate Check in this section. Are any signs of damage present on the clutch pressure plate? 	
B4	CHECK THE CLUTCH DISC	<p>Yes GO to B5.</p> <p>No INSTALL a new clutch disc. REFER to Section 308-01. TEST the system for normal operation.</p>
	<ul style="list-style-type: none"> Carry out the clutch disc inspection procedure. Refer to Clutch Disc Check in this section. Is the clutch disc OK? 	
B5	INSPECT THE FLYWHEEL	<p>Yes GO to B6.</p> <p>No REPAIR or INSTALL a new flywheel as necessary. Refer to the appropriate section in Group 303 for the procedure. TEST the system for normal operation.</p>
	<ul style="list-style-type: none"> Inspect the flywheel for damage and runout. Refer to Flywheel Runout Check in this section. Is the flywheel OK? 	
B6	INSPECT THE PILOT BEARING	<p>Yes INSTALL a new pilot bearing. REFER to Section 308-01.</p> <p>No GO to B7.</p>
	<ul style="list-style-type: none"> Inspect the pilot bearing for wear or damage. Are there signs of wear or damage? 	
B7	INSPECT THE INPUT SHAFT	<p>Yes INSTALL a new input shaft. Refer to the appropriate section in Group 308 for the procedure.</p> <p>No VERIFY the customer concerns. GO to Symptom Chart if necessary.</p>
	<ul style="list-style-type: none"> Inspect the input shaft for signs of wear or damage. Are any signs of wear or damage present on the input shaft? 	

DIAGNOSIS AND TESTING (Continued)

Pinpoint Test C: Clutch Pedal Feels Spongy or Has Excessive Travel/Clutch Will Not Disengage

Normal Operation

The clutch is designed to transfer the power from the engine to the transmission, which may be either stationary (starting) or rotating at a different speed (upshifting or downshifting). The clutch is functioning correctly when both the engine and transmission are rotating at the same speed with the clutch engaged. Clutch pedal movement is transmitted by fluid pressure, which actuates the clutch release hub and bearing. The clutch release hub and bearing pushes on the spring center towards the flywheel. The diaphragm spring pivots at the fulcrum, relieving the load on the clutch pressure plate. Steel spring straps riveted in the clutch pressure plate cover pull the clutch pressure plate from the clutch disc, disengaging the engine torque from the transmission.

This pinpoint test is intended to diagnose the following:

- Internal operation
- Clutch pedal reserve
- Clutch slave cylinder travel
- Clutch disc
- Clutch pressure plate
- Clutch pedal free play

PINPOINT TEST C: CLUTCH PEDAL FEELS SPONGY OR HAS EXCESSIVE TRAVEL/CLUTCH WILL NOT DISENGAGE

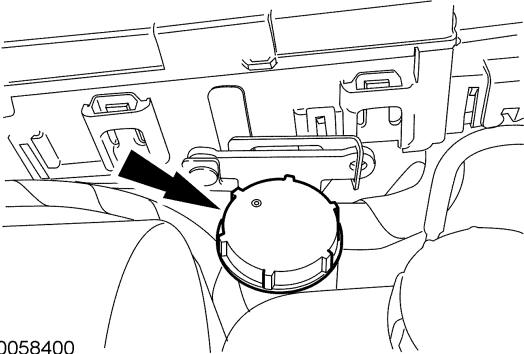
Test Step		Result / Action to Take
C1	<p>CHECK THE FLUID LEVEL</p> <ul style="list-style-type: none"> • NOTE: Do not check the hydraulic system after the road test. Allow the vehicle to cool down before carrying out the clutch hydraulic system check. Remove the brake and clutch reservoir cap.  <p>A0058400</p> <ul style="list-style-type: none"> • Check the fluid level of the brake and clutch reservoir. • Is the fluid level at or above the step mark? 	<p>Yes INSTALL the reservoir cap. GO to C2.</p> <p>No ADD brake fluid to the specified level. GO to C2.</p>
C2	<p>INSPECT THE HYDRAULIC SYSTEM FOR LEAKAGE</p> <ul style="list-style-type: none"> • Check the reservoir and reservoir tubes for leakage. • Check the master cylinder and hydraulic tube for leakage. • Check the clutch slave cylinder and the hydraulic tube connection for leakage. • Are there any signs of leakage? 	<p>Yes INSTALL new components as necessary. TEST the system for normal operation.</p> <p>No GO to C3.</p>
C3	<p>CHECK INTERNAL OPERATION</p> <ul style="list-style-type: none"> • Remove the reservoir cap. • Have an assistant slowly depress and release the clutch pedal. • On the down stroke, the fluid level should not increase by more than 1 mm (0.039 in). • Does the fluid level increase more than 1 mm (0.039 in)? 	<p>Yes INSTALL a new cylinder master cylinder assembly.</p> <p>No GO to C4.</p>

(Continued)

DIAGNOSIS AND TESTING (Continued)

PINPOINT TEST C: CLUTCH PEDAL FEELS SPONGY OR HAS EXCESSIVE TRAVEL/CLUTCH WILL NOT DISENGAGE (Continued)

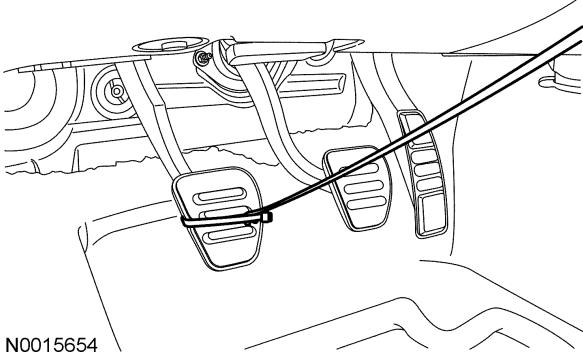
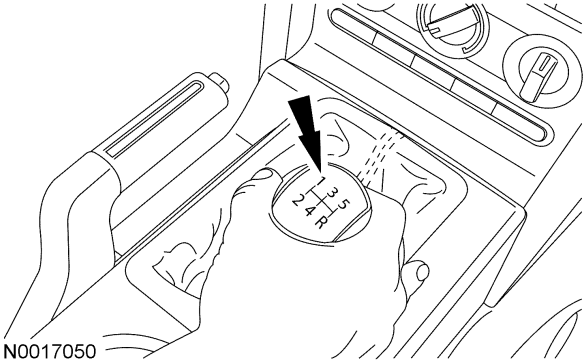
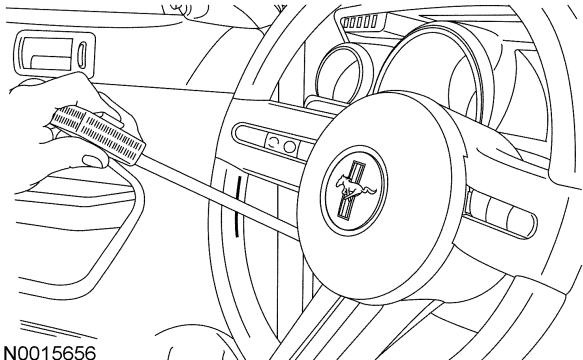
Test Step		Result / Action to Take
C4	CHECK THE CLUTCH PEDAL RESERVE	
	<p>NOTE: The clutch reserve is the distance between the clutch pedal when fully depressed and the position when the vehicle starts to move forward.</p> <ul style="list-style-type: none"> • Park the vehicle on a level surface. • Check for obstructions behind clutch pedal. • Attach a cable tie to the lower clutch pedal.  <p>N0015654</p> <ul style="list-style-type: none"> • Attach a tape measure to the cable tie. • Depress the clutch fully and start the vehicle. • Shift the transmission into 1st gear.  <p>N0017050</p> <ul style="list-style-type: none"> • Use the seam on the steering wheel as a reference point.  <p>N0015656</p>	

(Continued)

DIAGNOSIS AND TESTING (Continued)**PINPOINT TEST C: CLUTCH PEDAL FEELS SPONGY OR HAS EXCESSIVE TRAVEL/CLUTCH WILL NOT DISENGAGE (Continued)**

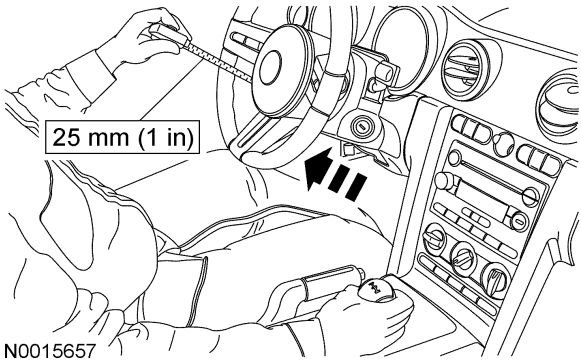
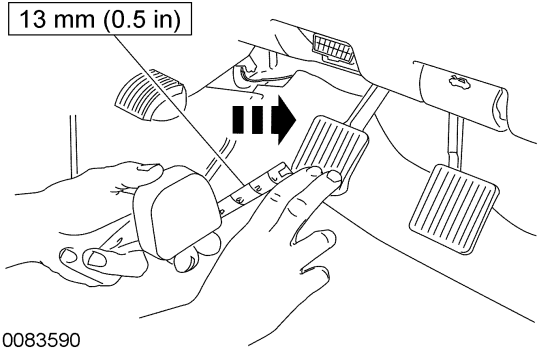
Test Step		Result / Action to Take
C4	CHECK THE CLUTCH PEDAL RESERVE (Continued)	
	<ul style="list-style-type: none"> While observing the tape measure, slowly engage the clutch, noting when the vehicle starts to move forward.  <p>N0015657</p> <ul style="list-style-type: none"> Is the clutch pedal reserve greater than or equal to 25 mm (1 in)? 	<p>Yes The clutch hydraulic system is OK. TEST the system for normal operation.</p> <p>No GO to C5.</p>
C5	CHECK THE CLUTCH PRESSURE PLATE	
	<ul style="list-style-type: none"> Remove the clutch pressure plate. Refer to Section 308-01. Inspect the clutch pressure plate for wear or runout. Refer to Clutch Pressure Plate Check in this section. Are there any signs of excessive wear or runout to the clutch pressure plate? 	<p>Yes INSTALL a new clutch pressure plate. REFER to Section 308-01.</p> <p>No GO to C6.</p>
C6	INSPECT THE CLUTCH DISC	
	<p>NOTE: Vehicles equipped with a 4.0L engine use an inner floating damper design disc. When inspecting the disc, a rattle type noise can be heard. This is a normal condition.</p> <ul style="list-style-type: none"> Carry out the clutch disc inspection procedure in this section. Is the clutch disc OK? 	<p>Yes GO to C7.</p> <p>No INSTALL a new clutch disc. REFER to Section 308-01. TEST the system for normal operation.</p>
C7	CHECK CLUTCH PEDAL FREE PLAY	
	<p>NOTE: The clutch pedal free play is the distance between the clutch pedal when fully released and the position when slight resistance is felt on downward motion.</p> <ul style="list-style-type: none"> Engine OFF. Attach a tape measure to the cable tie. While observing the tape measure, slowly push downward on the clutch pedal until a slight resistance is felt.  <p>N0083590</p> <ul style="list-style-type: none"> Is the clutch pedal free play less than 13 mm (0.5 in)? 	<p>Yes The clutch hydraulic system is OK. TEST the system for normal operation.</p> <p>No BLEED the clutch hydraulic system. REFER to Clutch System Bleeding in this section. TEST the system for normal operation.</p>

DIAGNOSIS AND TESTING (Continued)**Pinpoint Test D: Clutch Drag, Also Hard to Shift****Normal Operation**

The clutch is designed to transfer the power from the engine to the transmission, which may be either stationary (starting) or rotating at a different speed (upshifting or downshifting). The clutch is functioning correctly when both the engine and transmission are rotating at the same speed with the clutch engaged. Clutch pedal movement is transmitted by fluid pressure, which actuates the clutch release hub and bearing. The clutch release hub and bearing pushes on the spring center towards the flywheel. The diaphragm spring pivots at the fulcrum, relieving the load on the clutch pressure plate. Steel spring straps riveted in the clutch pressure plate cover pull the clutch pressure plate from the clutch disc, disengaging the engine torque from the transmission.

This pinpoint test is intended to diagnose the following:

- Internal operation
- Clutch pedal reserve
- Clutch slave cylinder travel
- Clutch disc
- Clutch pressure plate
- Clutch pedal free play

PINPOINT TEST D: CLUTCH DRAG, ALSO HARD TO SHIFT

Test Step		Result / Action to Take
D1	CHECK FLUID LEVEL	Yes INSTALL the reservoir cap. GO to D2 . No ADD brake fluid. GO to D2 and CHECK for leaks. TEST the system for normal operation.
	<ul style="list-style-type: none"> • Ignition OFF. • Remove the reservoir cap. • Inspect the fluid level in the brake and clutch reservoir. • Is the fluid level at or above the step mark? 	
D2	INSPECT THE CLUTCH HYDRAULIC SYSTEM FOR LEAKAGE	Yes INSTALL new components as necessary. TEST the system for normal operation. No GO to D3 .
	<ul style="list-style-type: none"> • Inspect the clutch master cylinder and the hydraulic tubes for leakage. • Inspect the reservoir and reservoir tube for leakage. • Inspect the clutch slave cylinder and the hydraulic tube connection for leakage. • Are there any signs of leakage? 	
D3	CHECK INTERNAL OPERATION	Yes INSTALL a new cylinder master cylinder assembly. No GO to D4 .
	<ul style="list-style-type: none"> • Remove the reservoir cap. • Have an assistant slowly depress and release the clutch pedal. • On the down stroke, the fluid level should not increase by more than 1 mm (0.039 in). • Does the fluid level increase more than 1 mm (0.039 in)? 	
D4	CHECK THE CLUTCH PEDAL RESERVE	
	NOTE: The clutch reserve is the distance between the clutch pedal when fully depressed and the position when the vehicle starts to move forward. <ul style="list-style-type: none"> • Park the vehicle on a level surface. • Check for obstructions behind the clutch pedal. Check the carpet for correct installation. Remove the floor mat. 	

(Continued)

DIAGNOSIS AND TESTING (Continued)

PINPOINT TEST D: CLUTCH DRAG, ALSO HARD TO SHIFT (Continued)

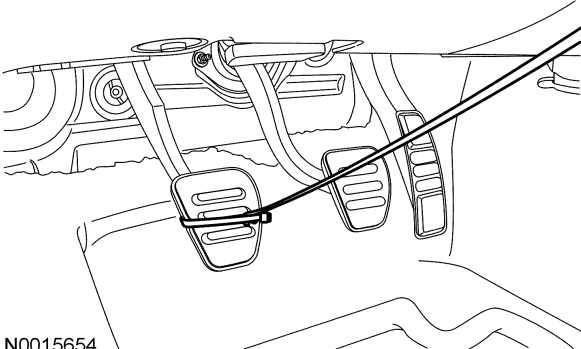
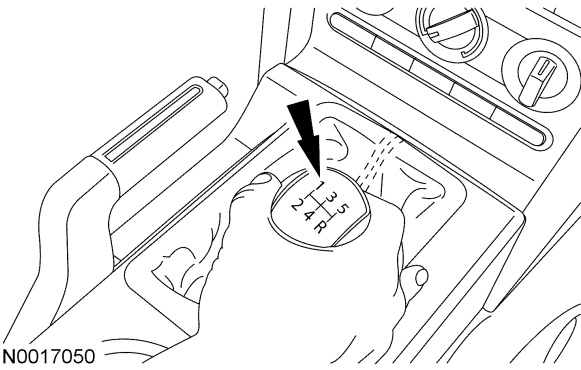
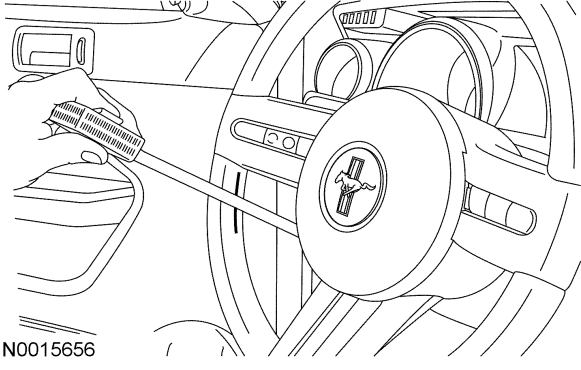
	Test Step	Result / Action to Take
D4	CHECK THE CLUTCH PEDAL RESERVE (Continued)	
<ul style="list-style-type: none"> • Attach a cable tie to the lower clutch pedal.  <p>N0015654</p>		
<ul style="list-style-type: none"> • Attach a tape measure to the cable tie. • Depress the clutch fully and start the vehicle. • Shift the transmission into 1st gear.  <p>N0017050</p>		
<ul style="list-style-type: none"> • Use the seam on the steering wheel as a reference point.  <p>N0015656</p>		

(Continued)

DIAGNOSIS AND TESTING (Continued)

PINPOINT TEST D: CLUTCH DRAG, ALSO HARD TO SHIFT (Continued)

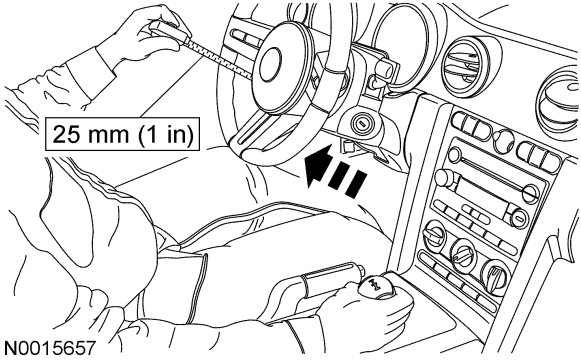
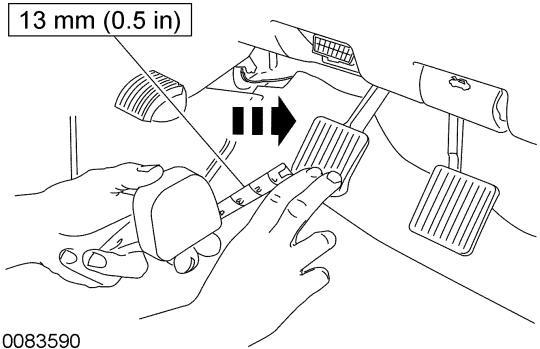
	Test Step	Result / Action to Take
D4	<p>CHECK THE CLUTCH PEDAL RESERVE (Continued)</p> <ul style="list-style-type: none"> While observing the tape measure, slowly engage the clutch, noting when the vehicle starts to move forward.  <p>N0015657</p> <ul style="list-style-type: none"> Is the clutch pedal reserve greater than or equal to 25 mm (1 in)? 	<p>Yes The clutch hydraulic system is OK. TEST the system for normal operation.</p> <p>No GO to D5.</p>
D5	<p>CHECK THE CLUTCH PEDAL FREE PLAY</p> <p>NOTE: The clutch pedal free play is the distance between the clutch pedal when fully released and the position when slight resistance is felt on downward motion.</p> <ul style="list-style-type: none"> Engine OFF. Attach a tape measure to the cable tie. While observing the tape measure, slowly push downward on the clutch pedal until a slight resistance is felt.  <p>N0083590</p> <ul style="list-style-type: none"> Is the clutch pedal free play less than 13 mm (0.5 in)? 	<p>Yes The clutch hydraulic system is OK. TEST the system for normal operation.</p> <p>No GO to D6.</p>
D6	<p>CHECK THE CLUTCH PRESSURE PLATE</p> <ul style="list-style-type: none"> Remove the clutch pressure plate. Refer to Section 308-01. Inspect the clutch pressure plate for wear or runout. Refer to Clutch Pressure Plate Check in this section. Are there any signs of excessive wear or runout to the clutch pressure plate? 	<p>Yes INSTALL a new clutch pressure plate. REFER to Section 308-01.</p> <p>No GO to D7.</p>
D7	<p>INSPECT THE CLUTCH DISC</p> <p>NOTE: Vehicles equipped with a 4.0L engine use an inner floating damper design disc. When inspecting the disc, a rattle type noise can be heard. This is a normal operation.</p> <ul style="list-style-type: none"> Carry out the clutch disc inspection procedure in this section. Is the clutch disc OK? 	<p>Yes GO to D8.</p> <p>No INSTALL a new clutch disc. REFER to Section 308-01. TEST the system for normal operation.</p>
D8	<p>INSPECT THE TRANSMISSION</p> <ul style="list-style-type: none"> Remove the transmission. Disassemble the transmission. Refer to the appropriate section in Group 308 for the procedure. 	

(Continued)

DIAGNOSIS AND TESTING (Continued)**PINPOINT TEST D: CLUTCH DRAG, ALSO HARD TO SHIFT (Continued)**

Test Step		Result / Action to Take
D8	INSPECT THE TRANSMISSION (Continued)	
	<ul style="list-style-type: none"> • Carry out the following: <ul style="list-style-type: none"> — Inspect all the shift rails for excessive scuffing or wear. — Check the interlock pins on the shift rail. — Make sure the interlock bolts are tightened to specifications. Refer to the appropriate section in Group 308 for the procedure. — Inspect the shift pads for wear or cracking. — Inspect the shift forks for wear or damage. — Check the synchronizer rings of the affected gear for wear or damage. — Check the synchronizer hubs of the affected gear for wear or damage. — Inspect the clutching teeth of the affected gear. • Are there any internal components worn or damaged? 	<p>Yes INSTALL new components or REPAIR as necessary. TEST the system for normal operation.</p> <p>No ASSEMBLE and INSTALL the transmission. TEST the system for normal operation.</p>

Pinpoint Test E: Clutch Pedal Pulsation**Normal Operation**

The clutch is designed to transfer the power from the engine to the transmission, which may be either stationary (starting) or rotating at a different speed (upshifting or downshifting). The clutch is functioning correctly when both the engine and transmission are rotating at the same speed with the clutch engaged. Clutch pedal movement is transmitted by fluid pressure, which actuates the clutch release hub and bearing. The clutch release hub and bearing pushes on the spring center towards the flywheel. The diaphragm spring pivots at the fulcrum, relieving the load on the clutch pressure plate. Steel spring straps riveted in the clutch pressure plate cover pull the clutch pressure plate from the clutch disc, disengaging the engine torque from the transmission.

This pinpoint test is intended to diagnose the following:

- Clutch disc
- Clutch pressure plate
- Flywheel

PINPOINT TEST E: CLUTCH PEDAL PULSATION

Test Step		Result / Action to Take
E1	CHECK THE CLUTCH PEDAL PULSATION	
	<ul style="list-style-type: none"> • Start the engine. • With the transmission in NEUTRAL, slowly press the clutch pedal. • Does the clutch pedal pulsate while being pressed? 	<p>Yes GO to E2.</p> <p>No VERIFY customer concern. GO to Symptom Chart if necessary.</p>
E2	INSPECT THE PRESSURE PLATE BOLTS	
	<ul style="list-style-type: none"> • Inspect the pressure plate-to-flywheel bolts. • Are any of the pressure plate-to-flywheel bolts loose? 	<p>Yes TIGHTEN or INSTALL new bolts. REFER to Section 308-01. TEST the system for normal operation.</p> <p>No GO to E3.</p>

(Continued)

DIAGNOSIS AND TESTING (Continued)**PINPOINT TEST E: CLUTCH PEDAL PULSATION (Continued)**

Test Step		Result / Action to Take
E3	INSPECT THE CLUTCH PRESSURE PLATE	Yes INSTALL a new clutch pressure plate. REFER to Section 308-01. TEST the system for normal operation. No GO to E4 .
	<ul style="list-style-type: none"> Remove the clutch pressure plate. Refer to Section 308-01. Inspect the clutch pressure plate for damage. Refer to Clutch Pressure Plate Check in this section. Are there any signs of damage present on the clutch pressure plate? 	
E4	INSPECT THE CLUTCH DISC	
	<ul style="list-style-type: none"> Carry out the clutch disc inspection procedure. Refer to Clutch Disc Check in this section. Is the clutch disc OK? 	Yes GO to E5 . No INSTALL a new clutch disc. REFER to Section 308-01. TEST the system for normal operation.
E5	INSPECT THE FLYWHEEL	Yes VERIFY customer concern. GO to Symptom Chart if necessary. No TIGHTEN or INSTALL a new flywheel as necessary. Refer to the appropriate section in Group 303 for the procedure. TEST the system for normal operation.
	<ul style="list-style-type: none"> Inspect the flywheel for damage and runout. Refer to Flywheel Runout Check in this section. Is flywheel OK? 	

Pinpoint Test F: Clutch-Related Vibrations**Normal Operation**

The clutch is designed to transfer the power from the engine to the transmission, which may be either stationary (starting) or rotating at a different speed (upshifting or downshifting). The clutch is functioning correctly when both the engine and transmission are rotating at the same speed with the clutch engaged. Clutch pedal movement is transmitted by fluid pressure, which actuates the clutch release hub and bearing. The clutch release hub and bearing pushes on the spring center towards the flywheel. The diaphragm spring pivots at the fulcrum, relieving the load on the clutch pressure plate. Steel spring straps riveted in the clutch pressure plate cover pull the clutch pressure plate from the clutch disc, disengaging the engine torque from the transmission.

This pinpoint test is intended to diagnose the following:

- Engine components
- Accessory drive belts
- Release bearing
- Flywheel

PINPOINT TEST F: CLUTCH-RELATED VIBRATIONS

Test Step		Result / Action to Take
F1	CHECK FOR ENGINE COMPONENT GROUNDING	Yes REPAIR the components as necessary. TEST the system for normal operation. No GO to F2 .
	<ul style="list-style-type: none"> With the vehicle in NEUTRAL, position it on a hoist. Refer to Section 100-02. Check the engine and transmission mounts for grounding. Check for exhaust manifolds or other engine component grounding on the body or frame. Is there evidence of grounding on the body or frame? 	

(Continued)

DIAGNOSIS AND TESTING (Continued)**PINPOINT TEST F: CLUTCH-RELATED VIBRATIONS (Continued)**

Test Step		Result / Action to Take
F2	CHECK FOR ACCESSORY DRIVE VIBRATIONS	Yes REFER to Section 303-05 to diagnose the accessory drive belt components. No STOP the engine and INSTALL the drive belt. GO to F3 .
	<ul style="list-style-type: none"> Start the engine. Remove the accessory drive belt. Does the vibration stop when the accessory drive belt is removed from the engine? 	
F3	CHECK FOR CLUTCH RELEASE BEARING NOISE	Yes INSTALL a new clutch release bearing. REFER to Section 308-01. No GO to F4 .
	NOTE: With the transmission in NEUTRAL, transmission rollover noise can be heard. Make sure to distinguish between rollover noise and clutch release bearing noise. <ul style="list-style-type: none"> Start the engine. Depress and hold the clutch pedal. Is a whirring, grating or grinding noise present only when pedal is pushed? 	
F4	INSPECT THE FLYWHEEL	Yes VERIFY customer concern. GO to Symptom Chart if necessary. No TIGHTEN or INSTALL a new flywheel. Refer to the appropriate section in Group 303 for the procedure. TEST the system for normal operation.
	<ul style="list-style-type: none"> Ignition OFF. Remove the transmission. Refer to the appropriate section in Group 308 for the procedure. Carry out a flywheel check. Refer to Flywheel Runout Check in this section. Is the flywheel OK? 	

Pinpoint Test G: Excessive Noise**Normal Operation**

The clutch is designed to transfer the power from the engine to the transmission, which may be either stationary (starting) or rotating at a different speed (upshifting or downshifting). The clutch is functioning correctly when both the engine and transmission are rotating at the same speed with the clutch engaged. Clutch pedal movement is transmitted by fluid pressure, which actuates the clutch release hub and bearing. The clutch release hub and bearing pushes on the spring center towards the flywheel. The diaphragm spring pivots at the fulcrum, relieving the load on the clutch pressure plate. Steel spring straps riveted in the clutch pressure plate cover pull the clutch pressure plate from the clutch disc, disengaging the engine torque from the transmission.

This pinpoint test is intended to diagnose the following:

- Transmission
- Clutch slave cylinder
- Pilot bearing

PINPOINT TEST G: EXCESSIVE NOISE

Test Step		Result / Action to Take
G1	TRANSMISSION NEUTRAL GEAR ROLLOVER TEST	Yes INSPECT the clutch components for damage. REFER to General Procedures in this section. No GO to G2 .
	<ul style="list-style-type: none"> Start the engine and let it idle with the transmission in NEUTRAL and the clutch engaged (pedal up). If noise is excessive, depress the clutch pedal to stop the transmission input shaft from rotating. Does the noise stop when the clutch pedal is depressed? 	

(Continued)

DIAGNOSIS AND TESTING (Continued)**PINPOINT TEST G: EXCESSIVE NOISE (Continued)**

Test Step		Result / Action to Take
G2	CHECK THE CLUTCH SYSTEM	Yes GO to G3 . No The clutch system is OK. VERIFY customer concern.
	<ul style="list-style-type: none"> • Engine OFF. • Using slow, medium, then fast strokes, depress and release the clutch pedal. • Is there a squeak? 	
G3	CHECK THE STARTER INTERLOCK SWITCH	Yes REINSTALL the starter interlock switch. GO to G4 . No INSTALL a new starter interlock switch. REFER to Section 308-02.
	<ul style="list-style-type: none"> • Remove the starter interlock switch. Using slow, medium, then fast strokes, depress and release the clutch pedal. • Is there a squeak? 	
G4	CHECK THE CLUTCH SLAVE CYLINDER	Yes INSTALL a new clutch slave cylinder. REFER to Section 308-01. No GO to G5 .
	<ul style="list-style-type: none"> • Remove the transmission. Refer to the appropriate section in Group 308 for the procedure. • Inspect the clutch slave cylinder for wear or loss of lubrication. Refer to Section 308-01. • Are there any signs of wear or loss of lubrication? 	
G5	CHECK THE PILOT BEARING	Yes GO to G6 . No INSTALL a new pilot bearing. REFER to Section 308-01.
	<ul style="list-style-type: none"> • Inspect the pilot bearing for wear or damage. • Is the pilot bearing OK? 	
G6	CHECK THE TORSION SPRINGS	Yes INSTALL a new clutch disc. REFER to Section 308-01. TEST the system for normal operation. No INSPECT the crankshaft end play.
	<ul style="list-style-type: none"> • Inspect the torsion springs for fatigue or breakage. • Are there any signs of fatigue or breakage? 	

GENERAL PROCEDURES

Clutch System Bleeding

Special Tool(s)

 <p>ST1176-A</p>	<p>Vacuum Pump Kit 416-D002 (D95L-7559-A) or equivalent</p>
---	---

Material

Item	Specification
High Performance DOT 3 Motor Vehicle Brake Fluid PM-1-C (US); CPM-1-C (Canada)	WSS-M6C62-A or WSS-M6C65-A1

⚠ WARNING: Carefully read cautionary information on product label. For **EMERGENCY MEDICAL INFORMATION** seek medical advice. In the USA or Canada on Ford/Motorcraft products call: 1-800-959-3673. For additional information, consult the product Material Safety Data Sheet (MSDS) if available. Failure to follow these instructions may result in serious personal injury.

NOTICE: Do not spill brake fluid on painted or plastic surfaces or damage to the surface may occur. If brake fluid is spilled onto a painted or plastic surface, immediately wash the surface with water.

1. Make sure all hydraulic tubes are correctly seated.
2. Make sure the clutch pedal is in the most upward position.
3. Check the fluid level of the brake/clutch reservoir. Fill the reservoir with the specified fluid to the MAX mark.
4. Using a suitable bleeder kit and a vacuum pump, install the rubber stopper in the reservoir opening. Make sure the rubber stopper has a tight fit.
 - Alternate method: use a 50 mm (1.96 in) rubber stopper with an 8 mm (0.31 in) pipe inserted through the rubber stopper.
5. Holding the rubber stopper in place, operate the vacuum pump to 15-20 inches of vacuum. Hold the vacuum for one minute, then quickly relieve the vacuum. Remove the special tools.
6. Check the fluid level of the reservoir. Fill the reservoir with the specified fluid to the MAX mark. Install the reservoir cap.
7. Depress and release the clutch pedal 10 to 12 times or until clutch pedal effort is consistent and positive at top of clutch pedal travel.
8. Repeat Steps 4 through 6 two additional times or until clutch pedal effort is consistent and positive at top of clutch pedal travel.
9. Install the reservoir cap.
10. Check the clutch pedal reserve. Test the clutch system for normal operation.

GENERAL PROCEDURES

Clutch Disc Check

Special Tool(s)

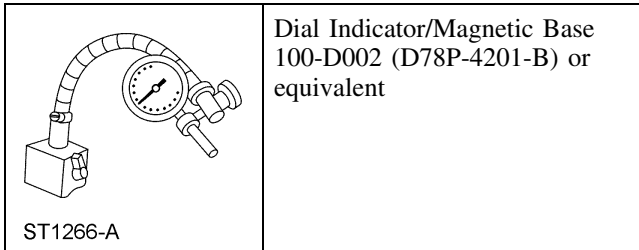

NOTE: The 5.4L application is an assembly of discs and plates. It is serviced as an assembly only.

1. Check the clutch disc for the following conditions. Install a new clutch disc as necessary.
 - Lining surface for hardening
 - Presence of oil
 - Loose clutch disc lining rivet
 - Cracking, scoring or other surface marks
 - Use an emery cloth to remove minor imperfections in the clutch disc lining surface
 - Discoloration

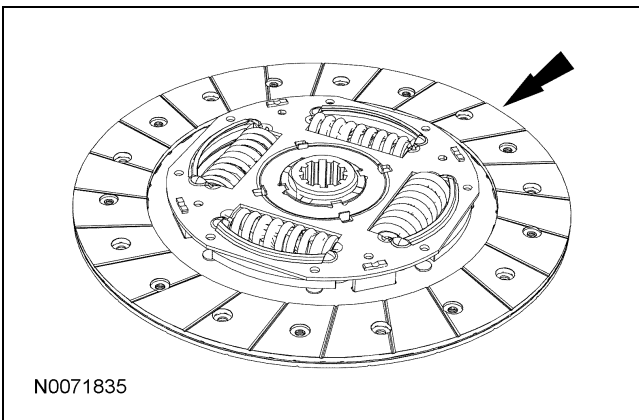

2. Check for a worn clutch disc lining. Measure the minimum allowable depth to the rivet heads with a slide caliper. Install a new clutch disc as necessary.

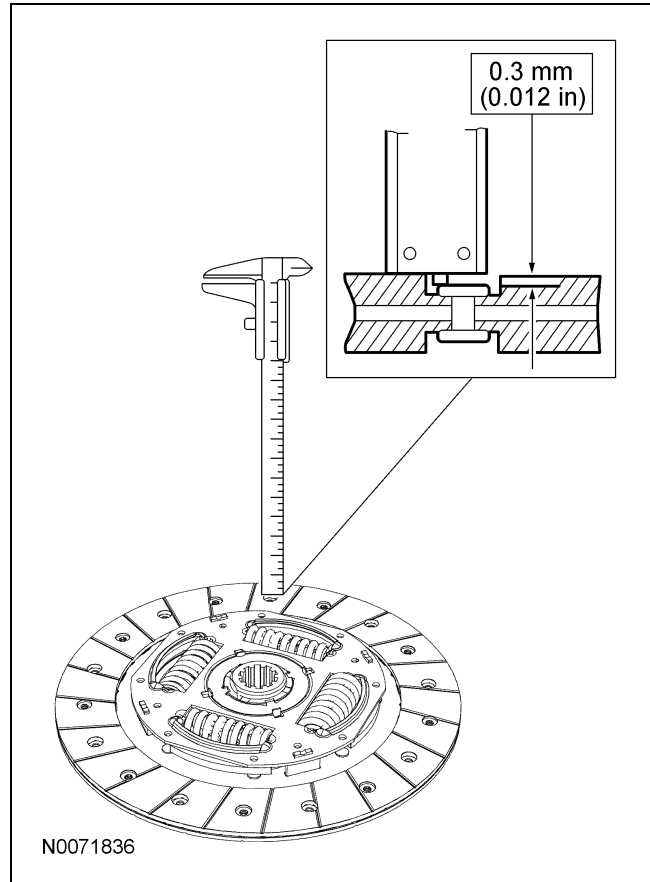

3. Using a suitable lathe and a Dial Indicator/Magnetic Base, check the maximum allowable runout of the clutch disc. Install a new clutch disc as necessary.

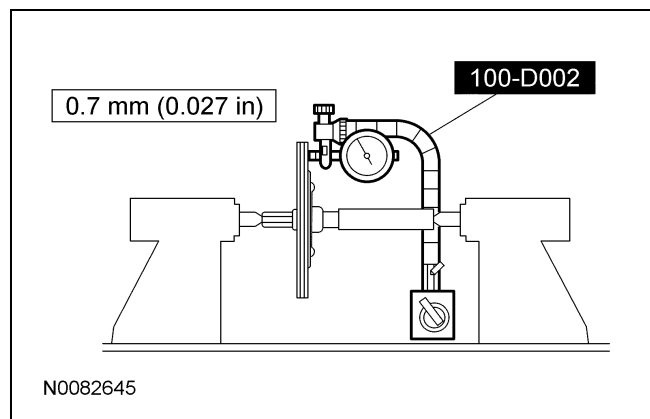

GENERAL PROCEDURES

Clutch Pressure Plate Check

NOTE: The 5.4L application is an assembly of discs and plates. It is serviced as an assembly only.

1. Check the clutch pressure plate surface for the following conditions. Install a new clutch pressure plate as necessary.
 - Cracking, scoring or other surface marks
 - Use an emery cloth to remove minor imperfections in the clutch pressure plate surface
 - Discoloration
2. Check the diaphragm spring fingers for the following conditions. Install a new clutch pressure plate as necessary.
 - Scoring, bent or broken segments
 - Spring ends that are higher or lower than the rest.
 - Discoloration
3. Measure the flatness of the clutch pressure plate surface with a straightedge and a feeler gauge.

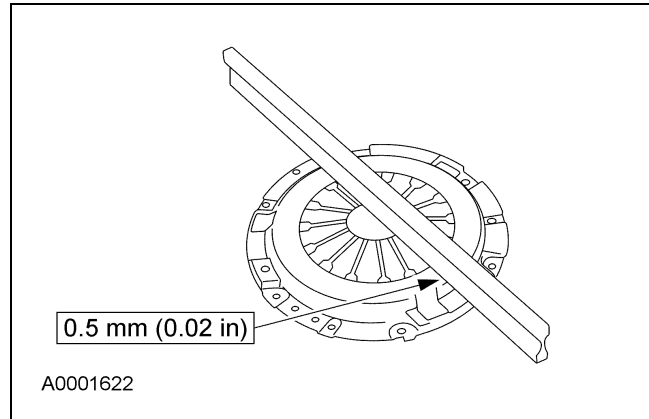

4. Measure the wear of the diaphragm spring fingers.

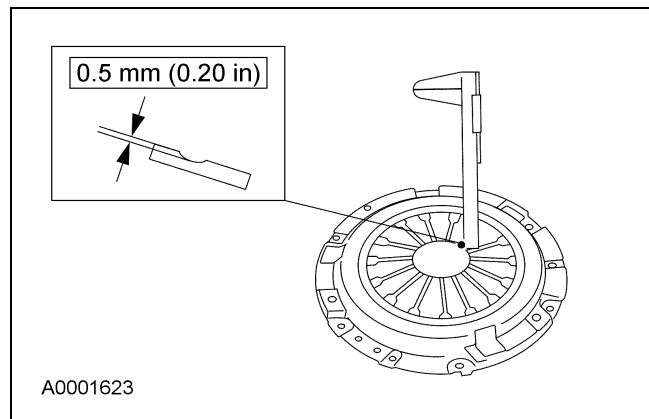

GENERAL PROCEDURES

Flywheel Runout Check

Special Tool(s)

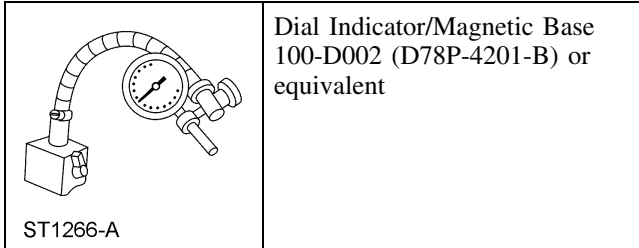

NOTE: Do not reface the flywheel surface. Install a new flywheel as necessary.

- NOTICE:** Do not use petroleum-based cleaning solutions. They will contaminate the clutch disc.

NOTE: Always inspect the flywheel whenever the clutch is removed or installed new.

Using a suitable cleaning solution, clean the flywheel clutch surface.

- Inspect the flywheel for the following conditions:
 - Surface cracks
 - Heat check
 - Glazing
 - Scoring
 - Scratches or grooves

■ For minor damage, finish the flywheel surface with coarse emery cloth or with a fine grade (400 grit) sandpaper.

- Inspect the ring gear for worn, chopped or broken teeth.
- Mount the Dial Indicator/Magnetic Base so that the indicator contact point rides on the clutch disc contact surface.
- Rotate the flywheel and measure the runout. If the runout exceeds the maximum allowance, install a new flywheel. Refer to the appropriate section in Group 303 for the procedure.

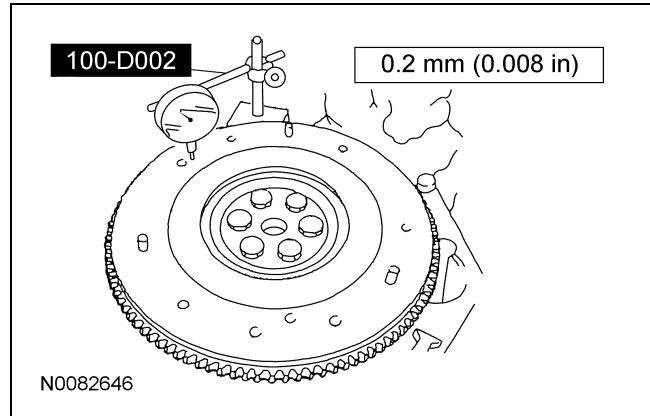

GENERAL PROCEDURES

Pilot Bearing Check

1. **NOTICE:** The pilot bearing is a sealed bearing and must not be immersed in any type of cleaning fluid or damage may occur.

Inspect the pilot bearing for the following conditions. Install a new pilot bearing as necessary. For additional information, refer to Section 308-01.

- Needle rollers for scoring, worn or broken rollers, cracked roller cage
- Inadequate grease
- Discoloration
- Seal leakage
- Misalignment and looseness in the crankshaft

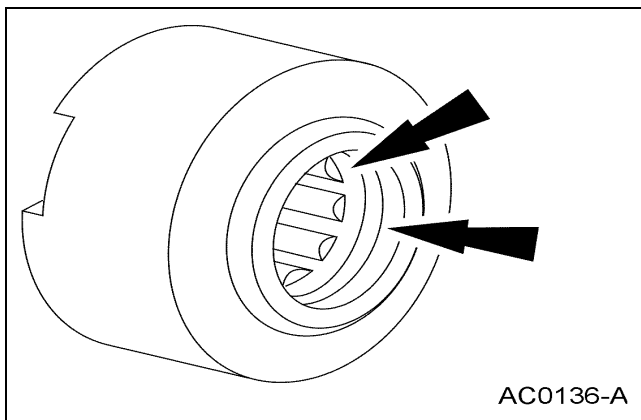

SPECIFICATIONS

Material

Item	Specification	Fill Capacity
Premium Long-Life Grease XG-1-C or XG-1-K (US); CXG-1-C (Canada)	ESA-M1C75-B	—
PTFE Lubricant XG-8	ESB-M1C111-B	—

General Specifications

Item	Specification
Clutch Disc	
4.0L	No. of springs: 4 springs Inner floating damper design
4.6L	No. of springs: 4 plain Color identification: no paint daub

General Specifications (Continued)

Item	Specification
5.4L	No. of springs: 6 springs
Pressure Plate	
Pressure plate diameter (4.0L)	254 mm (10.0 in)
Pressure plate diameter (4.6L)	280 mm (11.0 in)
Pressure plate diameter (5.4L)	215 mm (8.5 in)

Torque Specifications

Description	Nm	lb-ft
Pressure plate bolt (4.0L) ^a	—	—
Pressure plate bolt (4.6L) ^a	—	—
Pressure plate bolt (5.4L) ^a	—	—

a Refer to procedures in this section.

DESCRIPTION AND OPERATION

Clutch

The clutch operating mechanism consists of the following:

- Flywheel
- Pilot bearing
- Clutch disc/discs
- Clutch pressure plate
- Release bearing

The 4.0L or 4.6L clutch is a single plate, dry friction clutch disc with a diaphragm-style spring pressure plate. The clutch disc has a splined hub (with integral torsional dampening springs) which attaches the clutch disc to the input shaft. Engine output is coupled to the input shaft by the friction existing between the clutch disc facings and the flywheel/clutch pressure plate assembly.

The 5.4L clutch is a dry friction dual disc design. A vented cast intermediate plate separates the 2 discs. The clutch discs have splined hubs (with integral torsional dampening springs) which attach the clutch disc to the input shaft. Engine output is coupled to the input shaft by the friction existing between the clutch disc facings and the flywheel/clutch pressure plate assembly. The clutch discs and pressure plate are serviced as an assembly.

The primary function of the clutch is to transfer power from the engine to the drivetrain. The clutch connects and disconnects a manually operated transmission and the remainder of the drivetrain from the engine. This permits shifting and changing speeds that correspond to the engine speed through gear reductions, for both forward and reverse gears.

The clutch system is disengaged when the clutch pedal is depressed and engaged when the clutch pedal is released. When the clutch pedal is depressed, it pushes the clutch master cylinder plunger, which transmits hydraulic pressure to the clutch slave cylinder. The slave cylinder engages and compresses through the release bearing and the clutch pressure plate diaphragm spring, releasing the pressure on the clutch disc. This displacement removes the spring load from the clutch pressure plate and eliminates the coupling friction between the engine and the transmission.

DIAGNOSIS AND TESTING

Clutch

Refer to Section 308-00.

REMOVAL AND INSTALLATION

Clutch Disc and Pressure Plate — 4.0L

Clutch Disc and Pressure Plate

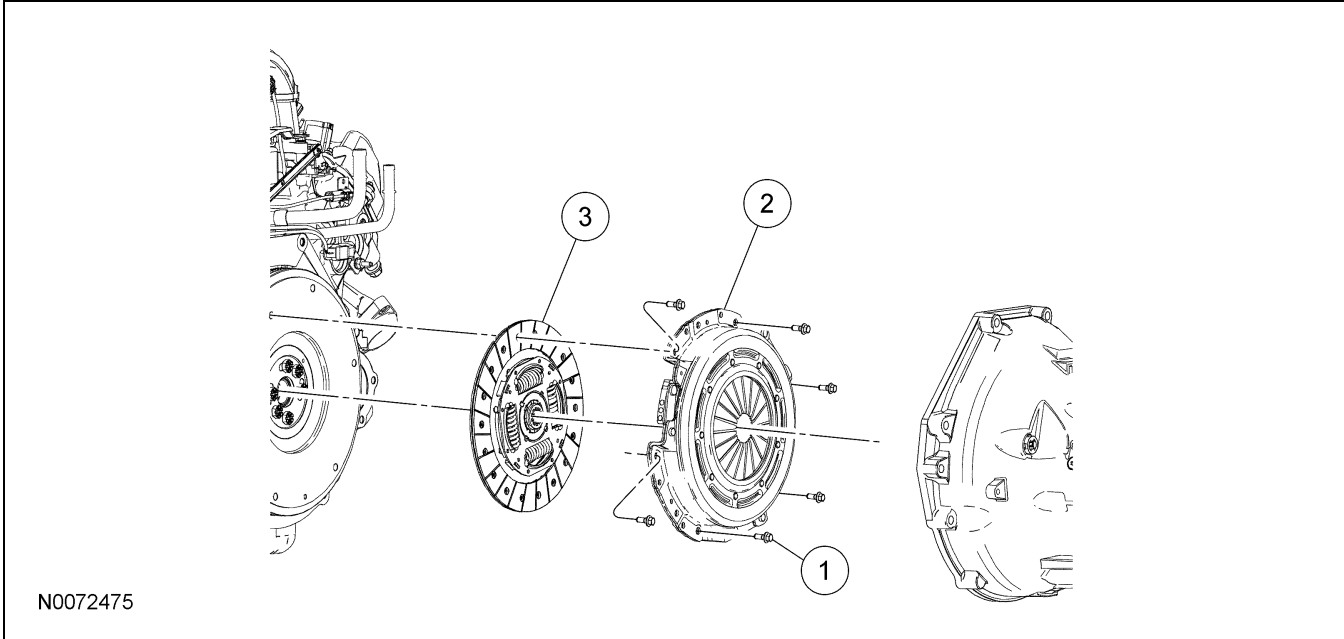

Item	Part Number	Description
1	W709479	Clutch pressure plate bolt (6 required)
2	7563	Clutch pressure plate
3	7550	Clutch disc

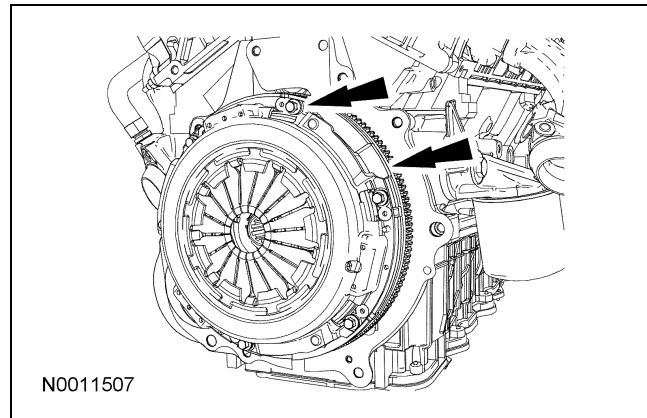

Removal

1. Remove the transmission. For additional information, refer to Section 308-03A.
2. **NOTICE: Loosen the bolts evenly to prevent clutch pressure plate damage.**
NOTE: If the parts are to be reused, index-mark the pressure plate to the flywheel.
 Remove the 6 pressure plate bolts, then remove the pressure plate and the clutch disc.
 - Discard the pressure plate bolts.

Installation

- NOTE:** If installing the original pressure plate, align it using the index marks made during removal.
- NOTE:** Always install new pressure plate bolts.
1. Inspect the flywheel. For additional information, refer to Flywheel Runout Check in Section 308-00.

REMOVAL AND INSTALLATION (Continued)

2. Using a suitable clutch aligner, position the clutch disc on the flywheel, then install the pressure plate and 6 new pressure plate bolts.
 - Tighten the bolts in a star pattern.
 - Tighten to 35 Nm (26 lb-ft).
 3. **NOTE:** Before securing the transmission to the engine, connect the clutch hydraulic tube to the slave cylinder.
Install the transmission. For additional information, refer to Section 308-03A.
 4. Bleed the clutch hydraulic system. For additional information, refer to Section 308-00.
-

REMOVAL AND INSTALLATION

Clutch Disc and Pressure Plate — 4.6L

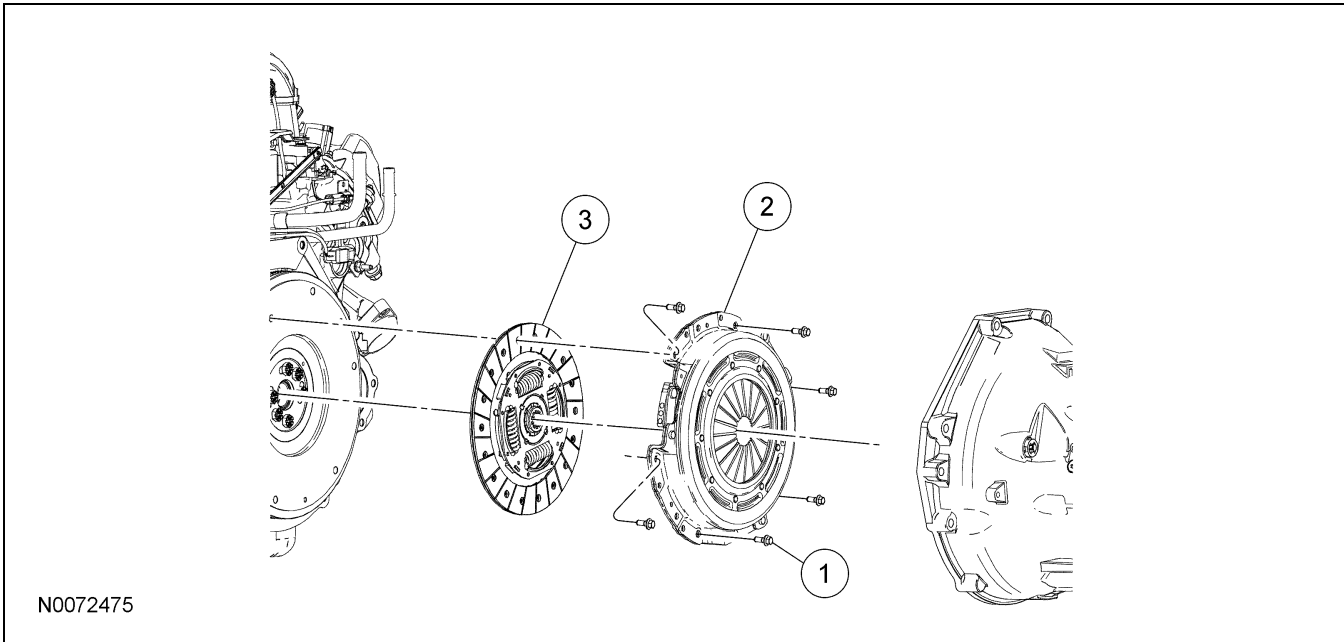

Item	Part Number	Description
1	N808969	Clutch pressure plate bolt (6 required)
2	7563	Pressure plate
3	7550	Clutch disc

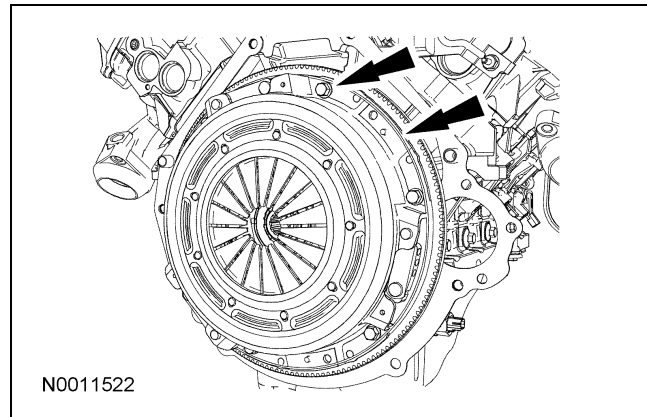

Removal

1. Remove the transmission. For additional information, refer to Section 308-03B.
2. **NOTICE: Loosen the bolts evenly to prevent damage to the pressure plate.**

NOTE: If the pressure plate is to be reused, index-mark the pressure plate to the flywheel.

Remove the 6 pressure plate bolts, then remove the pressure plate and the clutch disc.

- Discard the pressure plate bolts.

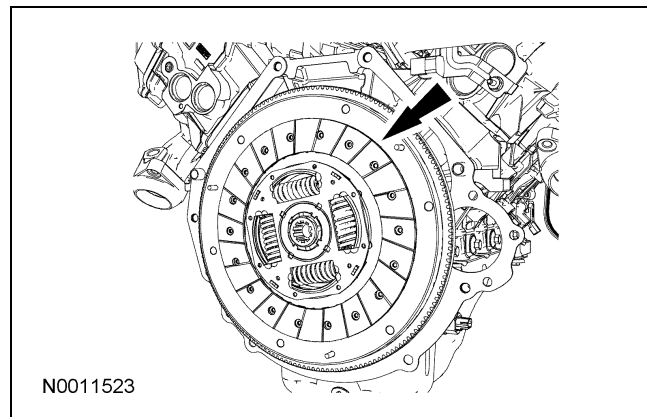

REMOVAL AND INSTALLATION (Continued)**Installation**

1. Inspect the flywheel. For additional information, refer to Flywheel Runout Check in Section 308-00.
2. **NOTE:** If installing the original pressure plate, align it using the index marks made during removal.

NOTE: Always install new pressure plate bolts.

Using a suitable clutch aligner, position the clutch disc on the flywheel, then install the pressure plate and 6 new pressure plate bolts.

- Tighten the pressure plate bolts in 2 stages in a star pattern.
 - Stage 1: Tighten to 45 Nm (33 lb-ft).
 - Stage 2: Tighten an additional 60 degrees.

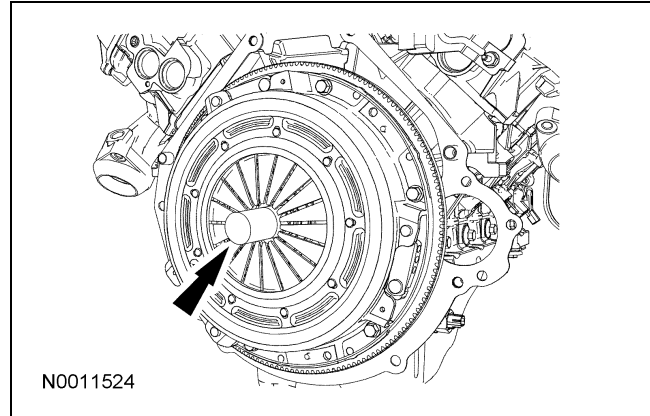

3. **NOTE:** Before securing the transmission to the engine, connect the clutch hydraulic tube to the slave cylinder.
Install the transmission. For additional information, refer to Section 308-03B.
4. Bleed the clutch hydraulic system. For additional information, refer to Section 308-00.

REMOVAL AND INSTALLATION

Clutch Disc and Pressure Plate — 5.4L

Material

Item	Specification
PTFE Lubricant XG-8	ESB-MIC111-B

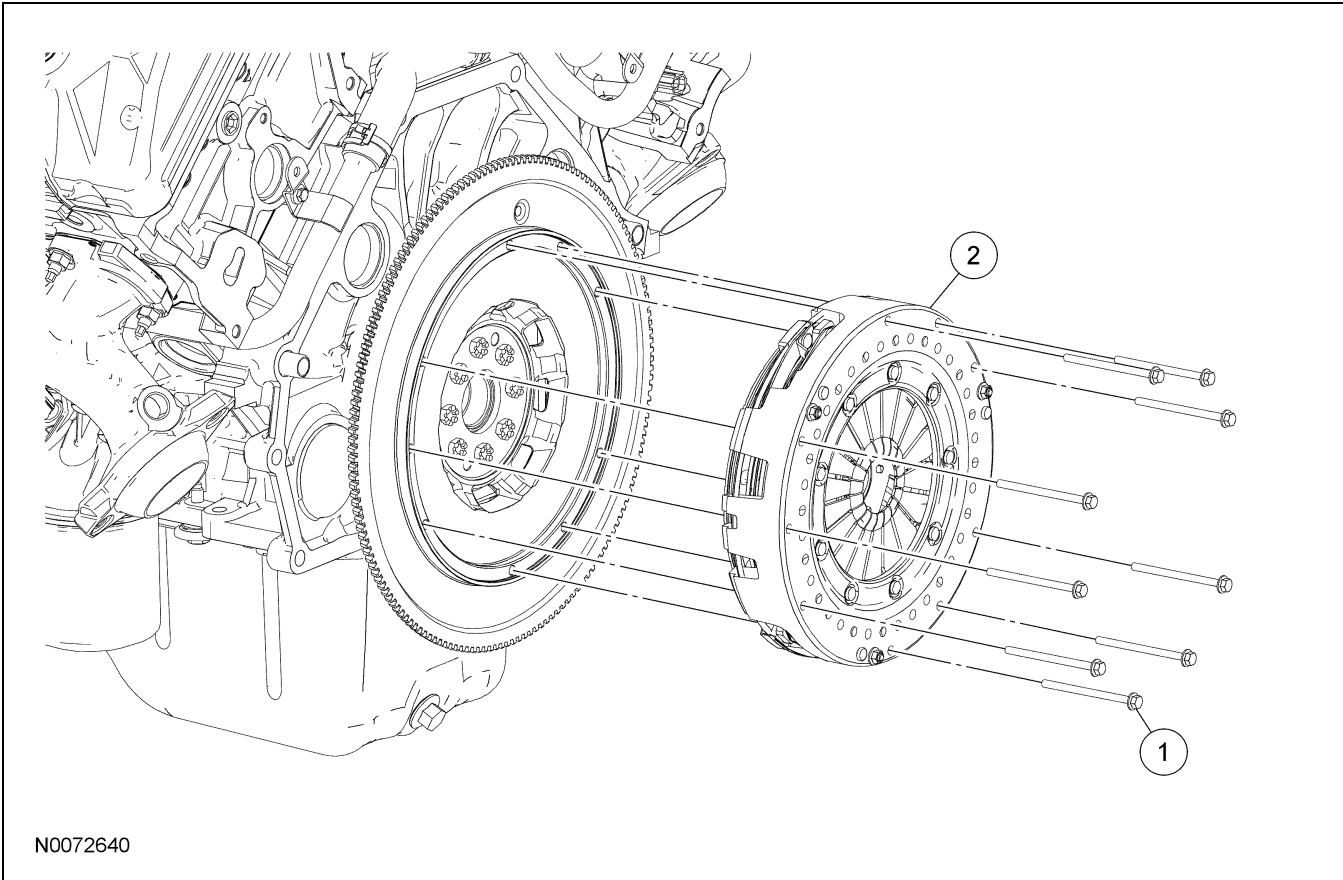

Item	Part Number	Description
1	W712838	Disc and plate assembly bolt (9 required)
2	7B546	Clutch disc and plate assembly

- NOTICE:** Loosen the bolts evenly to prevent damage to the pressure plate.

NOTE: If the pressure plate is to be reused, index-mark the pressure plate to the flywheel.

Remove the 9 pressure plate bolts, then remove the pressure plate and the clutch disc.

- Discard the pressure plate bolts.

Removal

- Remove the transmission. For additional information, refer to Section 308-03C.

REMOVAL AND INSTALLATION (Continued)

Installation

All vehicles

1. Inspect the flywheel. For additional information, refer to Flywheel Runout Check in Section 308-00.

Vehicles with spoke design flywheel

2. **NOTE:** If installing the original plate and disc assembly, align it using the index marks made during removal.

NOTE: Always install new pressure plate bolts.

Using a suitable clutch aligner, position the clutch disc on the flywheel, then install the pressure plate and 9 new pressure plate bolts.

- Tighten in a cross pattern to 9 Nm (80 lb-in).

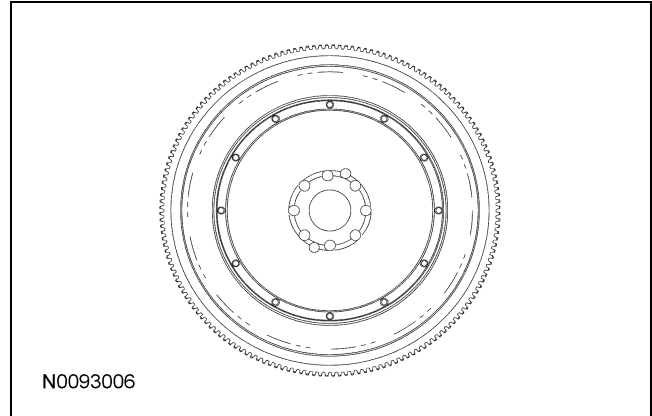
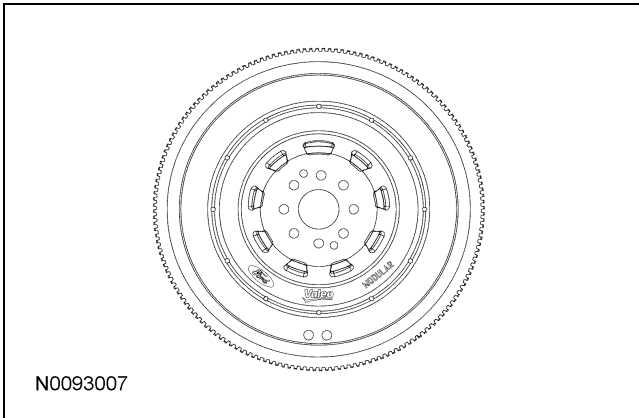

All vehicles

4. Remove the clutch aligner.
5. **NOTICE:** Apply a small amount of PTFE lubricant to the splines of the clutch hub. This will make sure that the clutch will not bind on the transmission input shaft, making sure of correct clutch operation. Using lubricant other than Motorcraft PTFE lubricant may cause clutch chatter.

NOTE: Before securing the transmission to the engine, connect the clutch hydraulic line to the slave cylinder.

Install the transmission. For additional information, refer to Section 308-03C.

6. Bleed the clutch hydraulic system. For additional information, refer to Section 308-00.

Vehicles with solid design flywheel

3. **NOTE:** If installing the original plate and disc assembly, align it using the index marks made during removal.

NOTE: Always install new pressure plate bolts.

Using a suitable clutch aligner, position the clutch disc on the flywheel, then install the pressure plate and 9 new pressure plate bolts. Tighten the bolts in 2 stages using a cross pattern.

- 1 Tighten to 10 Nm (89 lb-in).
- 2 Tighten an additional 90 degrees.

REMOVAL AND INSTALLATION

Pilot Bearing

Special Tool(s)

 <p>ST1282-A</p>	<p>Remover, Pilot Bearing 308-001 (T58L-101-B)</p>
---	--

Removal

1. Remove the clutch disc and the clutch pressure plate. For additional information, refer to Clutch Disc and Pressure Plate — 4.0L, Clutch Disc and Pressure Plate — 4.6L or Clutch Disc and Pressure Plate — 5.4L in this section.
2. Using the Pilot Bearing Remover, remove the pilot bearing.

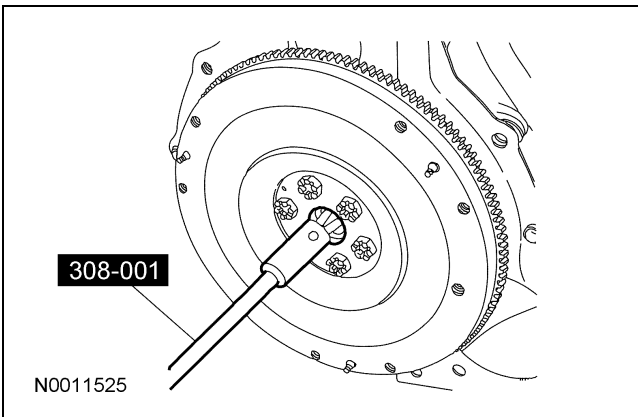

Installation

1. Position the pilot bearing to the crankshaft.
Using a suitable driver, install the pilot bearing.

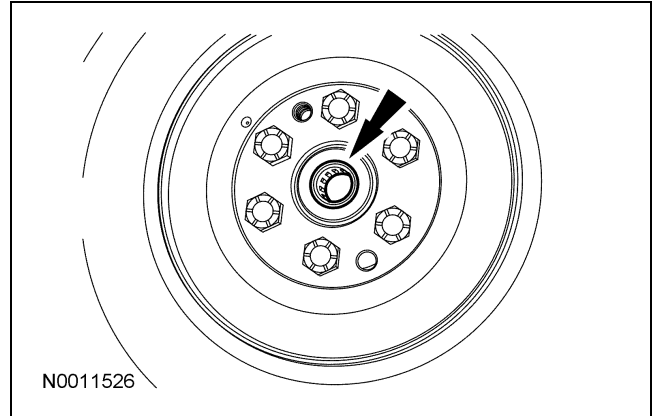

2. Install the clutch disc and the clutch pressure plate. For additional information, refer to Clutch Disc and Pressure Plate — 4.0L, Clutch Disc and Pressure Plate — 4.6L or Clutch Disc and Pressure Plate — 5.4L in this section.

SPECIFICATIONS

Material

Item	Specification	Fill Capacity
High Performance DOT 3 Motor Vehicle Brake Fluid PM-1-C (US); CPM-1-C (Canada)	WSS-M6C62-A	—

General Specifications

Item	Specification
Clutch System	

General Specifications (Continued)

Item	Specification
Hydraulic	Self adjusting

Torque Specifications

Description	Nm	lb-ft	lb-in
Clutch master cylinder bolts	10	—	89
Clutch slave cylinder	20	15	—

DESCRIPTION AND OPERATION

Clutch Controls

The clutch control system consists of the following components:

- Clutch pedal
- Clutch master cylinder
- Clutch slave cylinder
- Clutch hydraulic fluid tubes

The clutch control system disengages the clutch when the clutch pedal is depressed and engages the clutch when the clutch pedal is released. When the clutch pedal is depressed it pushes the clutch master cylinder plunger, which transmits hydraulic pressure to the clutch slave cylinder. The clutch slave cylinder engages and compresses the clutch pressure plate diaphragm spring, releasing the pressure on the clutch disc, which in turn disengages the transmission from the engine.

The hydraulic clutch system adjusts automatically to compensate for clutch disc wear.

The clutch pedal position (CPP) switch prevents the starter motor from engaging unless the clutch pedal is depressed all the way to the floor. The switch plunger is contacted by the clutch pedal and extends as the clutch pedal is pressed. The CPP switch is electrically connected in line with the ignition switch and the starter motor relay coil. The CPP switch also deactivates the speed control system and signals the electronic engine control (EEC) module when the clutch pedal is depressed.

DIAGNOSIS AND TESTING

Clutch Controls

Refer to Section 308-00.

REMOVAL AND INSTALLATION

Clutch Master Cylinder

Material

Item	Specification
High Performance DOT 3 Motor Vehicle Brake Fluid PM-1-C (US); CPM-1-C (Canada)	WSS-M6C62-A

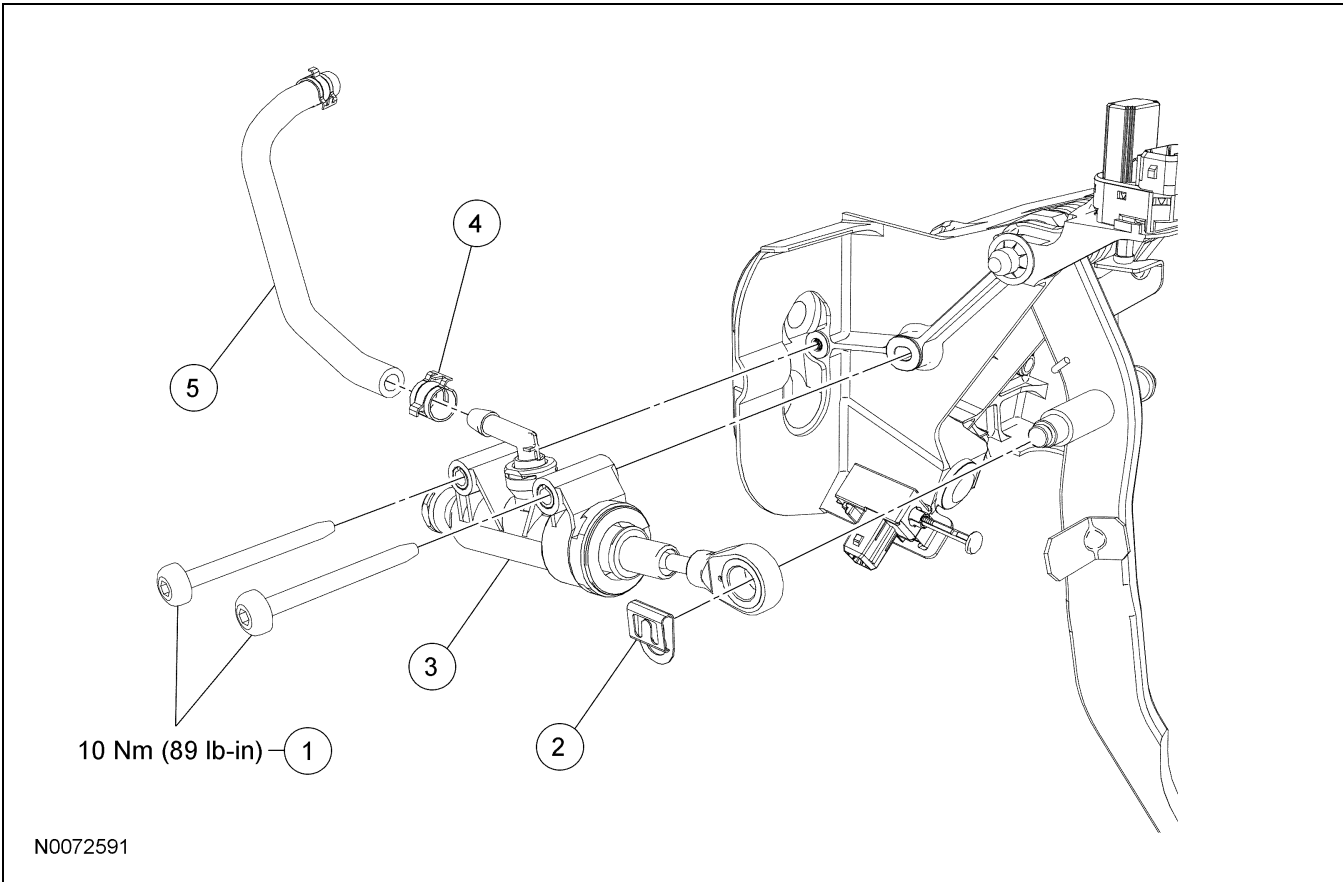



Item	Part Number	Description
1	—	Clutch master cylinder bolts (2 required)
2	—	Retaining clip

(Continued)

Item	Part Number	Description
3	7A543	Clutch master cylinder
4	—	Hose clamp
5	—	Reservoir hose

REMOVAL AND INSTALLATION (Continued)**Removal and Installation**

 **WARNING:** Carefully read cautionary information on product label. For **EMERGENCY MEDICAL INFORMATION** seek medical advice. In the USA or Canada on Ford/Motorcraft products call: 1-800-959-3673. For additional information, consult the product Material Safety Data Sheet (MSDS) if available. Failure to follow these instructions may result in serious personal injury.

 **CAUTION:** Brake fluid is harmful to painted or plastic surfaces. If the brake fluid is spilled onto a painted or plastic surface, wash immediately with cold water.

1. Remove the brake pedal and bracket assembly. For additional information, refer to Section 206-06.
 2. Remove the retaining clip from the clutch pedal pin.
 3. Remove the 2 clutch master cylinder bolts, then disconnect the clutch master cylinder from the clutch pedal.
 - To install, tighten to 10 Nm (89 lb-in).
 4. Remove the reservoir hose from the clutch master cylinder.
 5. To install, reverse the removal procedure.
 - Install new hose clamps on the reservoir hose.
 - Bleed the clutch hydraulic system. For additional information, refer to Section 308-00.
 - Refill the brake and clutch reservoir with the specified fluid.
 - Check the clutch for normal operation.
-

REMOVAL AND INSTALLATION

Clutch Slave Cylinder

Material

Item	Specification
High Performance DOT 3 Motor Vehicle Brake Fluid PM-1-C (US); CPM-1-C (Canada)	WSS-M6C62-A

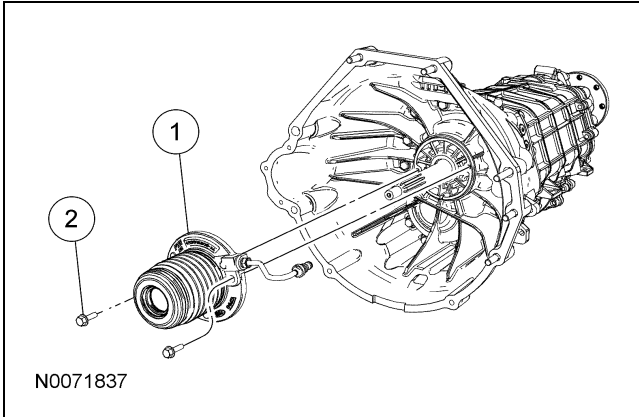

Item	Part Number	Description
1	7A508	Clutch slave cylinder
2	—	Clutch slave cylinder bolts (2 required)

Removal and Installation

1. Remove the transmission. For additional information, refer to Section 308-03A, Section 308-03B or Section 308-03C.
2. Place the transmission on a workbench.
3. Separate the connector from the clutch slave cylinder.

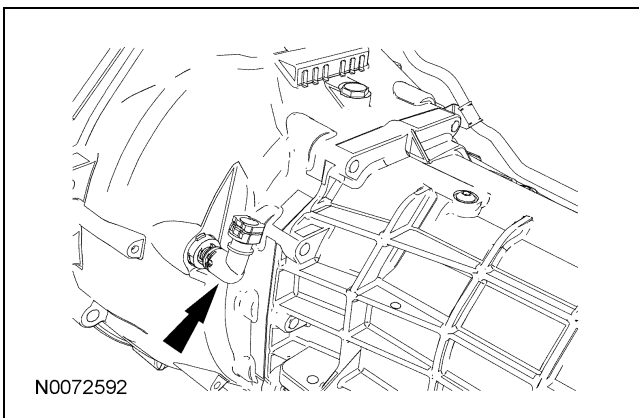

4. Remove the 2 clutch slave cylinder bolts. Pull the clutch slave cylinder outward and release the tube from the retaining clip.
5. Inspect the clutch slave cylinder for the following:
 - Damaged boot
 - Leaking brake fluid
 - Worn or damaged release bearing
 - Rotate the release bearing while applying pressure. If the bearing rotation is rough, install a new clutch slave cylinder.
6. Install a new retaining clip.

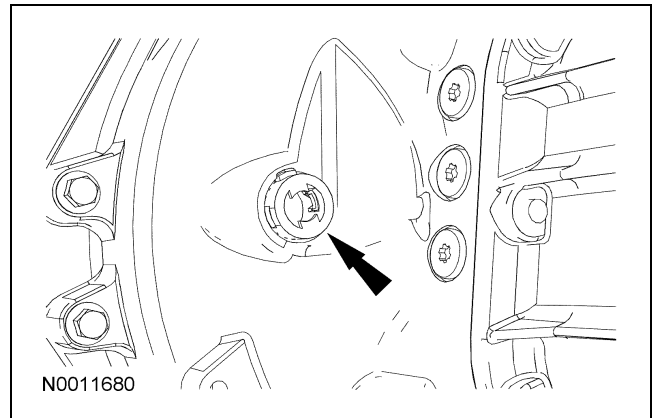

7. Position the clutch slave cylinder to the transmission, inserting the tube through the retaining clip. Install the 2 clutch slave cylinder bolts.
 - Tighten to 20 Nm (15 lb-ft).
 8. Install the connector.
 9. **NOTE:** Before securing the transmission to the engine, connect the hydraulic tube to the clutch slave cylinder. When connecting the hydraulic line, a click will be heard when the line is correctly connected. Tug on the line to make sure it is locked in the fitting.
- Install the transmission. For additional information, refer to Section 308-03A, Section 308-03B or Section 308-03C.

REMOVAL AND INSTALLATION (Continued)

10. Bleed the clutch hydraulic system. For additional information, refer to Section 308-00.
-